

**Miele**

Installation Plan  
**Tumble dryer**



PT 8303 SL EL (Electrically Heated)

en – US, CA

M.-Nr. 10 007 270 / 03

---

**Please have the model and serial number  
of your machine available when  
contacting Technical Service.**

---

## **U.S.A.**

**Miele, Inc.**

### **National Headquarters**

9 Independence Way  
Princeton, NJ 08540  
Phone: 800-991-9380  
[www.mieleusa.com/professional](http://www.mieleusa.com/professional)  
[prosales@mieleusa.com](mailto:prosales@mieleusa.com)

### **Technical Service & Support**

Phone: 800-991-9380  
[proservice@mieleusa.com](mailto:proservice@mieleusa.com)

## **Canada**

**Importer  
Miele Limited**

### **Professional Division**

161 Four Valley Drive  
Vaughan, ON L4K 4V8  
Phone: 1-888-325-3957  
[www.mieleprofessional.ca](http://www.mieleprofessional.ca)  
[professional@miele.ca](mailto:professional@miele.ca)

### **Miele Professional Technical Service**

Phone: 1-888-325-3957  
[serviceprofessional@miele.ca](mailto:serviceprofessional@miele.ca)



Manufacturer: Miele & Cie. KG  
Carl-Miele-Straße 29, 33332 Gütersloh, Germany

It is essential to read the operating and installation instructions before  
installing, commissioning or using the machine.  
This avoids the risk of accidents or damage.

All rights reserved

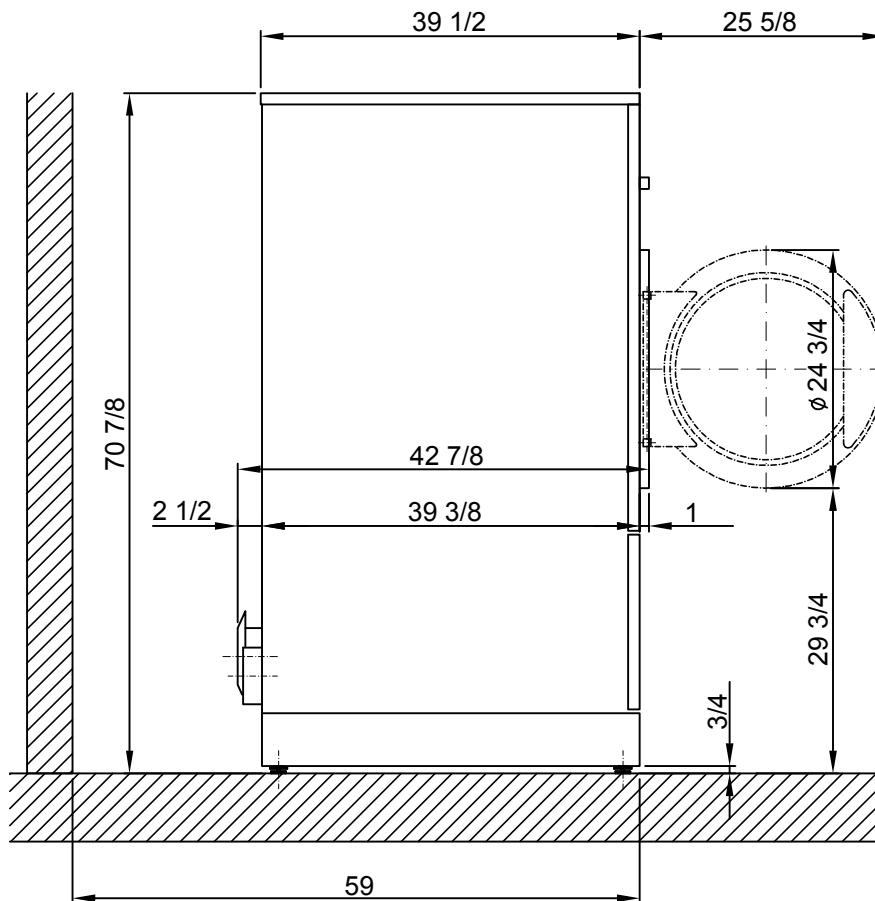
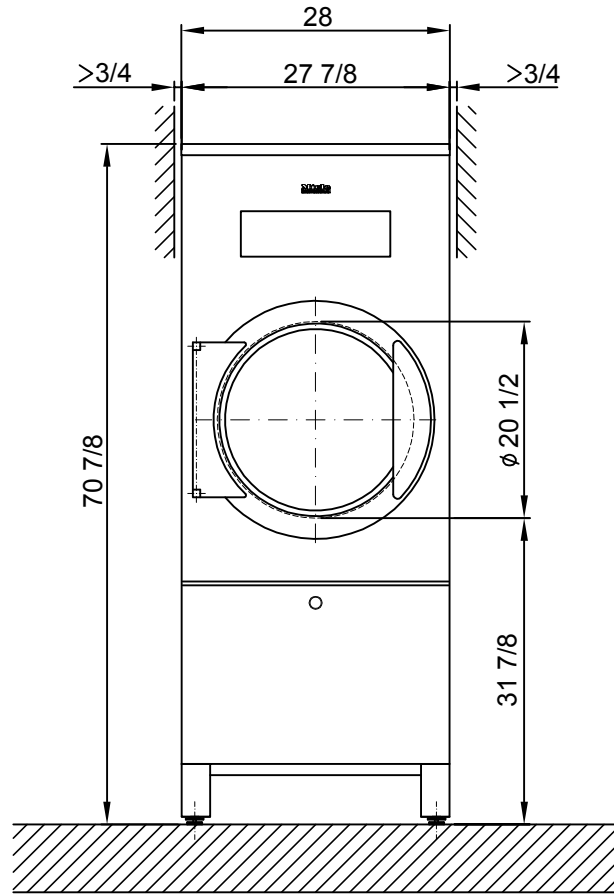

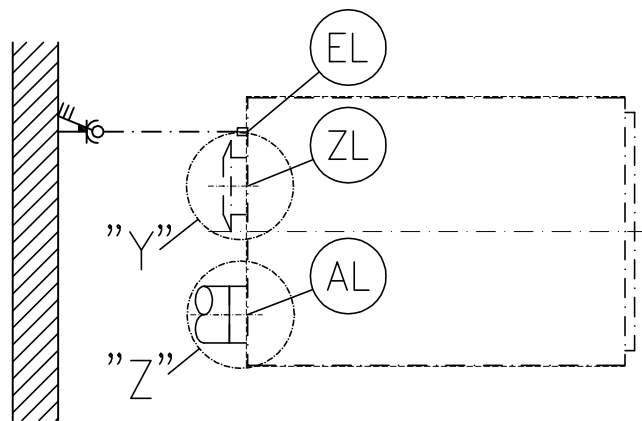
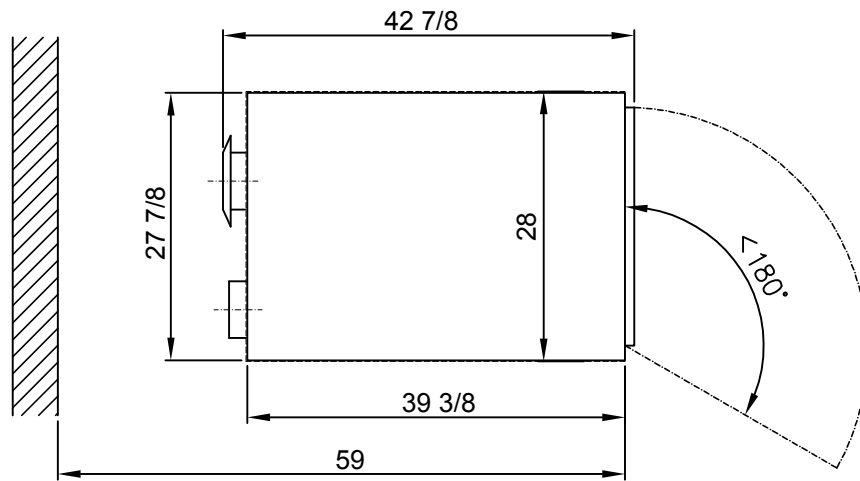

"Z"

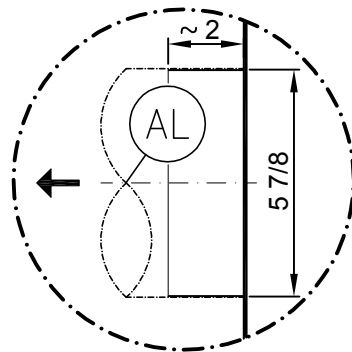

"Y"

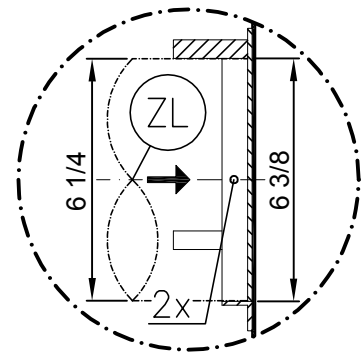

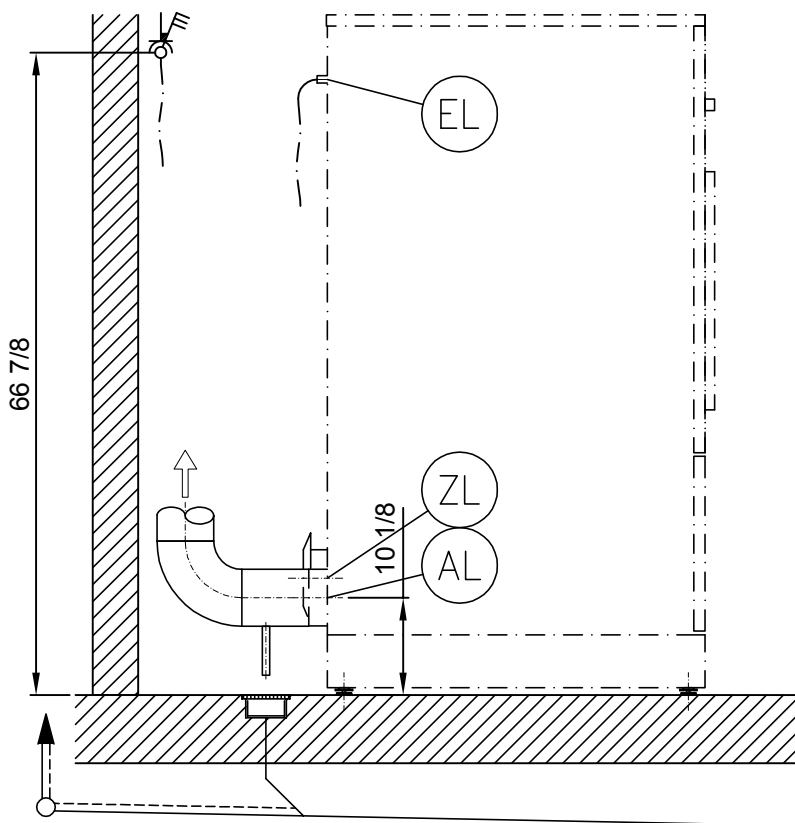
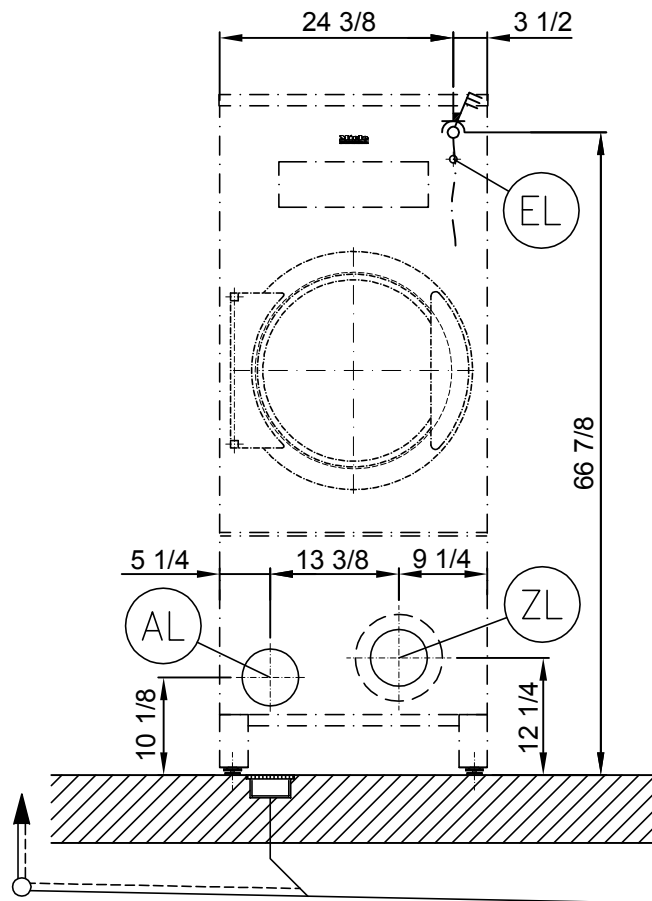

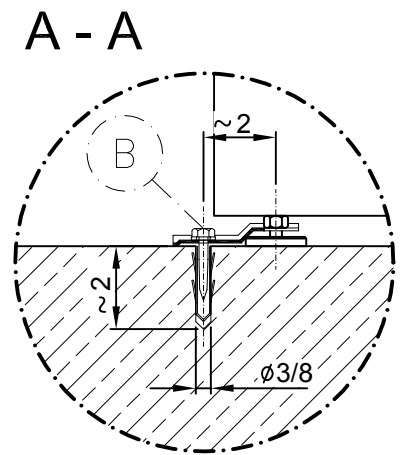
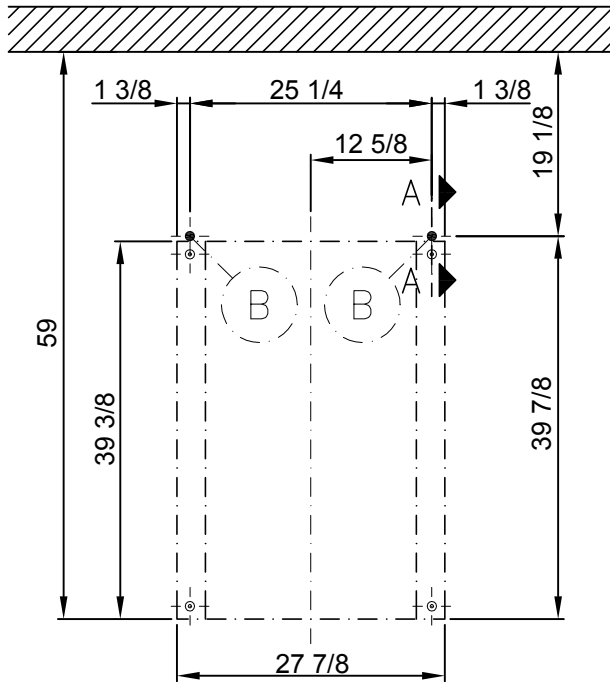
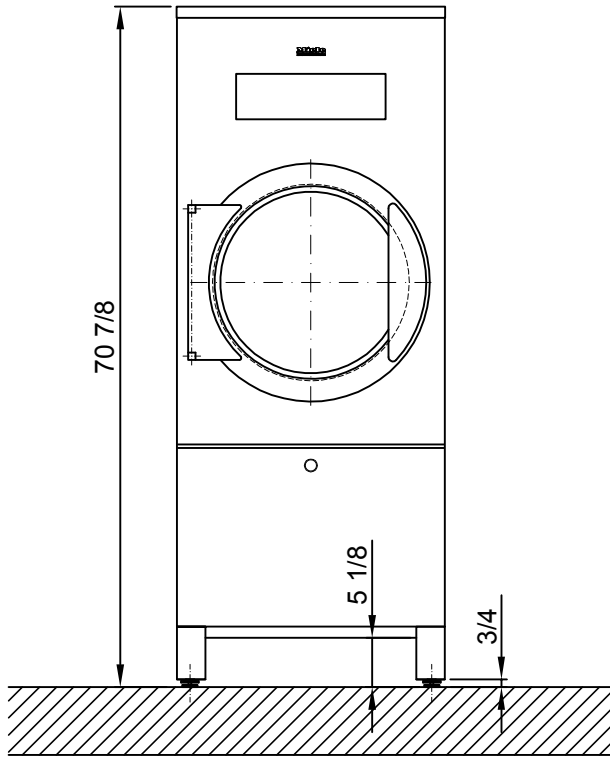

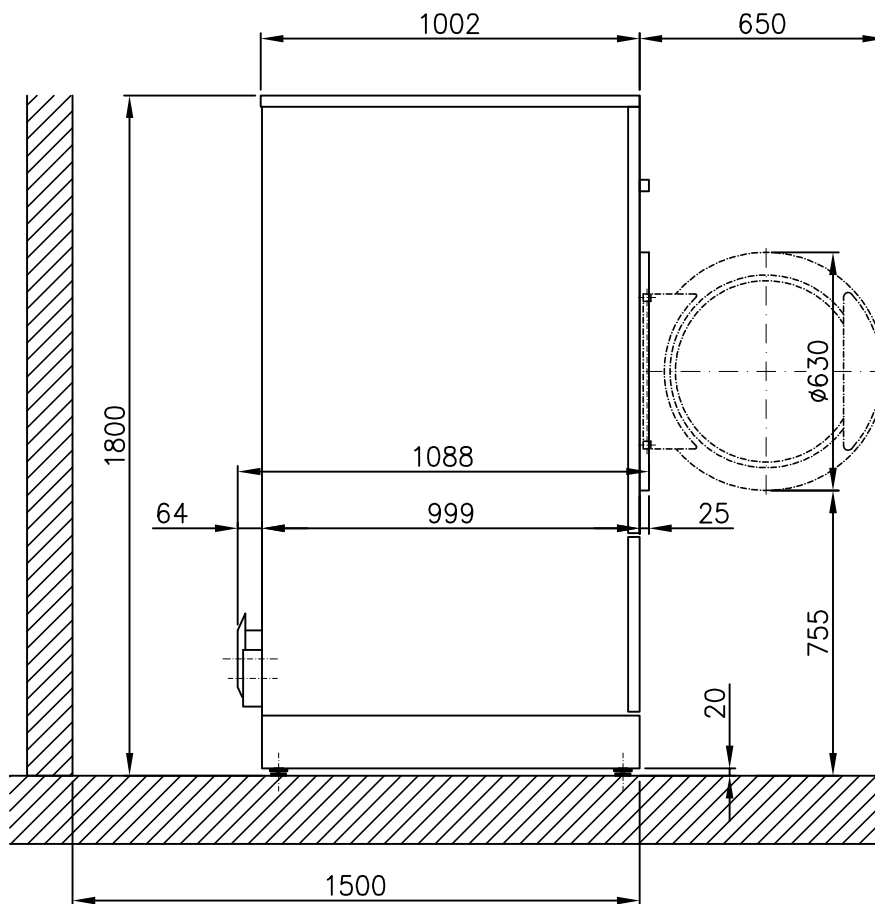
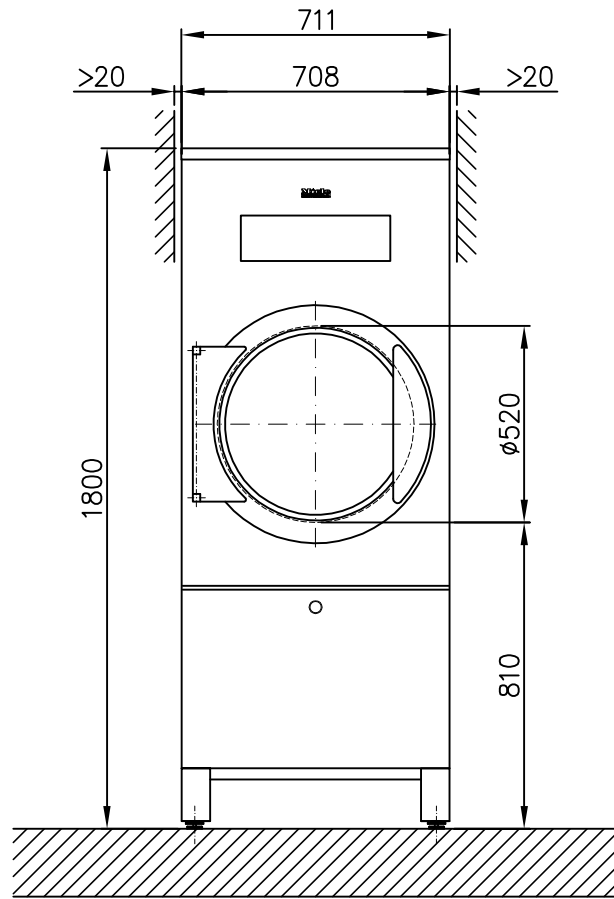

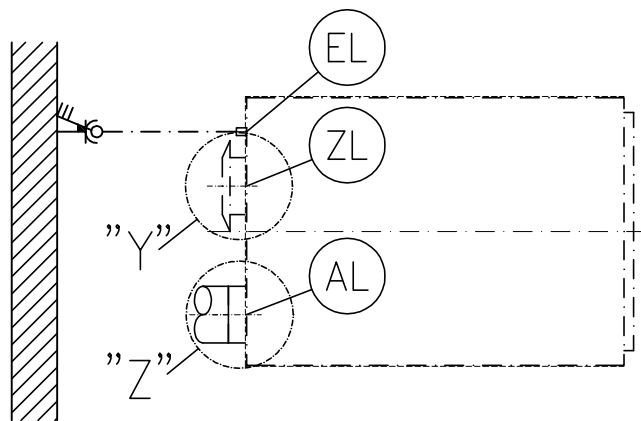
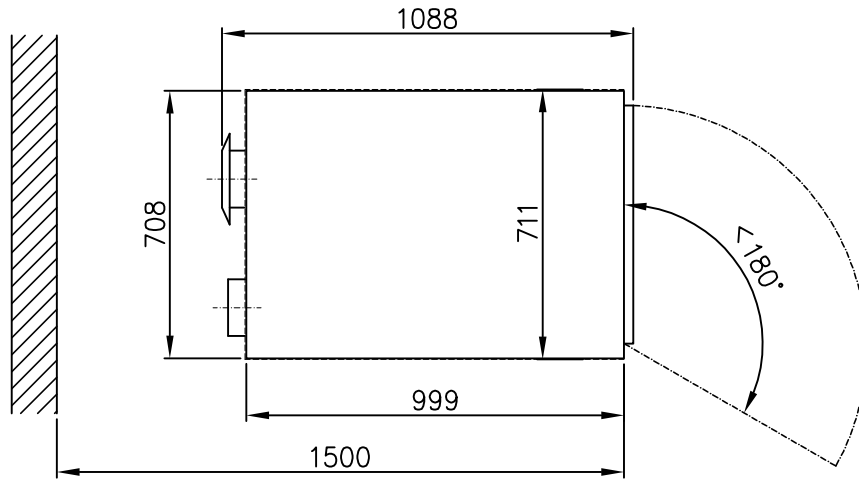

"Z"

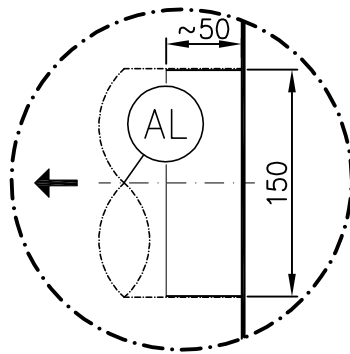

"Y"

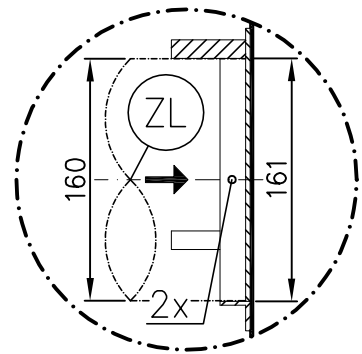



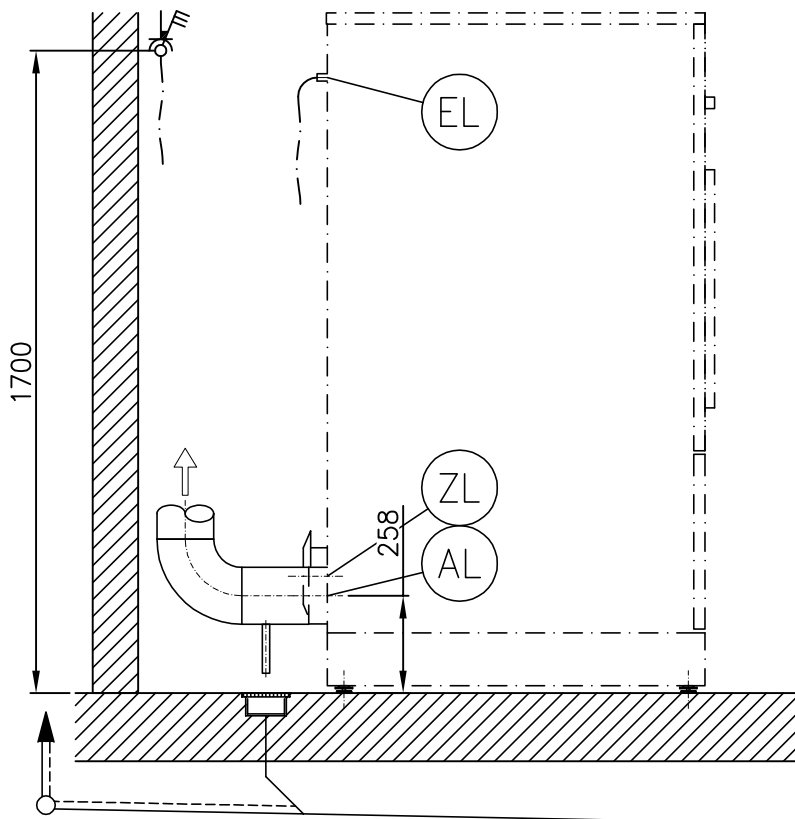
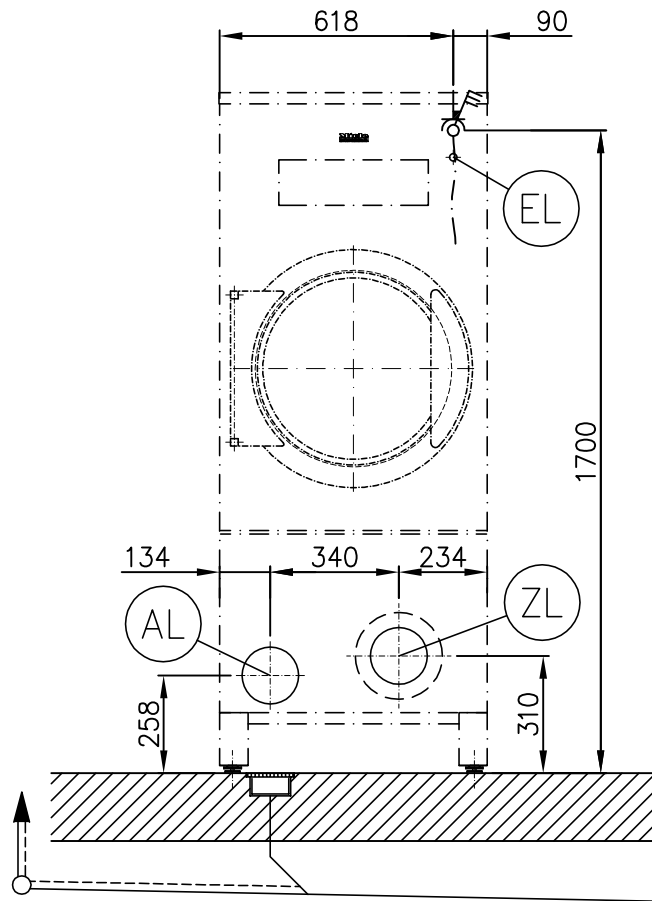

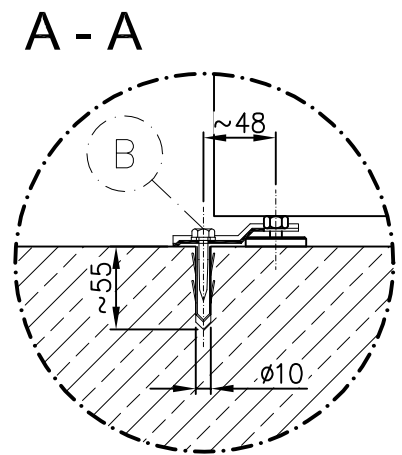
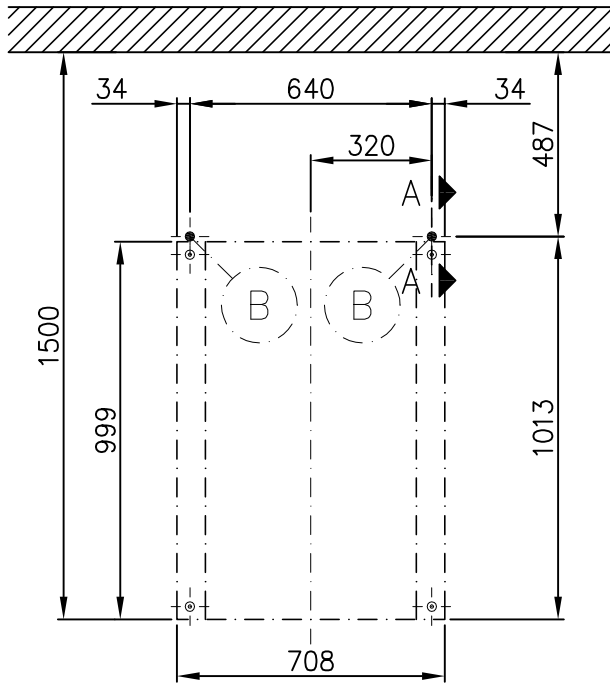
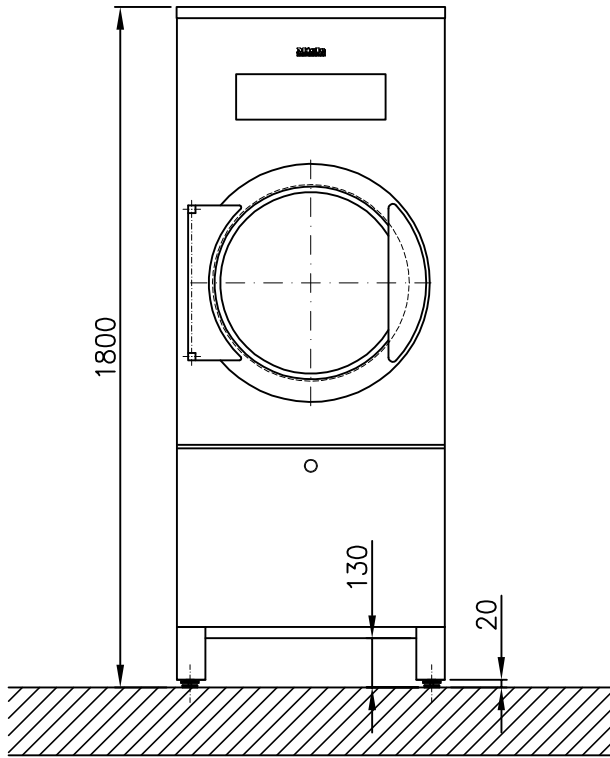

## Technical datasheet

Tumble dryer:  
Heating:

PT 8303 SL  
Electric (EL)

Legend:



Abbreviations in bold type:  
Connection required



Abbreviations in circle with dashes:  
Connection optional or required depending on model version

en - US

### Machine connections:

	<b>Electrical connection</b>	<b>Standard voltage</b> Frequency Rated load Fuse rating Supply lead cross-section	3 AC 220 - 240 V 60 Hz 15.4 kW 3 x 40 A 4 x 6 mm <sup>2</sup>	4 x 10 AWG
		<b>Convertible to</b> Frequency Rated load Fuse rating Supply lead cross-section	3 AC 208 V 60 Hz 11.7 kW 3 x 35 A 4 x 6 mm <sup>2</sup>	4 x 10 AWG
		<b>Convertible to</b> Frequency Rated load Fuse rating Supply lead cross-section	2 AC 208 V 60 Hz 8.1 kW 2 x 40 A 3 x 6 mm <sup>2</sup>	3 x 10 AWG
		Electrical connection must comply with national regulations. A wall socket or main isolator must be easily accessible after installation.  Reinstallation of the supply point, changes to the equipment or checks on the protective conductor, including determination of correct fuse rating, should only be performed by a trained electrician.		
	<b>Vented</b>	Nominal air throughput in vented mode Max. permissible pressure loss Waste air/gas temperature, max. Connector on machine (int. diameter) Connection pipe provided on site (ext. diameter)	821 m <sup>3</sup> /h 300 Pa 80 °C 150 mm 150 mm	28993 cfm 0.0435 psi 176 °F 5 15/16" 5 15/16"
		As relative humidity inside the vent ducting can be as high as 100%, suitable measures must be taken to prevent a back-flow of condensate into the machine.		
	<b>Air intake</b>	<b>Standard Connection:</b> ⇒ Air intake from installation site Min. air intake cross-section (to prevent draughts in room)  A sufficient supply of fresh air should be ensured to replace the air extracted.	531 cm <sup>2</sup>	82.305 in <sup>2</sup>
		<b>Alternative connection:</b> Ducted air intake (from outside build-ing) Connector on machine (int. diameter) Connection pipe provided on site (int. diameter)  Lid removal exposes live components! For safety reasons, the pipe connected for central air intake should be at least 900 mm long and secured using two screws.	161 mm 160 mm	6 5/16" 6 5/16"

B	<b>Fittings</b> (supplied)	<b>Without base</b> 2 x clamps 4 x screws DIN 571 (Ø x length) 4 x rawl plugs (Ø x length) The machine should be bolted to the floor. Fixing materials for a floating screed floor are to be provided on site.	6 mm x 40 mm 10 mm x 50 mm	1/4" x 1 9/16" 3/8" x 2"
	<b>Machine data</b>	Width Depth Height Casing width Casing depth Minimum width of delivery access to installation site Minimum rear wall gap (measured to front of machine) Wall gap (to front of machine) Minimum gap ensures sufficient space for maintenance and servicing.  Net weight Dynamic floor load, max. Average heat dissipation (dependent on ambient room temperature and programme selected)  Noise level Sound pressure (re 20 mPA), workplace-related (at distance of 1 m and height of 1.6 m)	711 mm 1088 mm 1800 mm 708 mm 999 mm 725 mm 1500 mm 500 mm  139 kg 1584 N 473 W  68.9dB (A) 56 dB (A)	28" 42 7/8" 70 7/8" 27 7/8" 39 5/16" 28 9/16" 59 1/16" 19 11/16"  306.4 lbs 1615 BTU/h
Installation should only be carried out by authorized installers in accordance with national regulations! Follow installation instructions when installing machine!				