

Operating and installation instructions Induction hobs



To avoid the risk of accidents or damage to the appliance it is **essen-**
tial to read these instructions before it is installed and used for the
first time.

Contents

Warning and Safety instructions	5
Caring for the environment	18
Guide to the appliance	19
Hob.....	19
Controls / Indicators.....	20
Cooking zones.....	22
Before using for the first time	23
Cleaning the hob for the first time	23
Switching on the hob for the first time	23
Miele@home	24
Induction	27
How it works.....	27
Pans.....	27
Power management	29
Noises.....	30
How the vapour extraction works	31
Tips on saving energy	32
Setting ranges	33
Operation	34
Using the appliance.....	34
Switching on the hob	35
Setting the power level.....	35
Changing the power level.....	35
Switching off a cooking zone/the hob.....	35
Residual heat indicator.....	36
Setting the power level – extended setting range	36
PowerFlex XL cooking area.....	37
Auto heat-up	38
Booster function.....	39
Keeping warm	40
Vapour extraction	41
Timer	43
Minute minder	43
Switching off a cooking zone automatically.....	44
Additional functions	45
Stop & Go.....	45

Recall.....	45
Wipe protection	46
Demo mode.....	46
Displaying hob data.....	46
Safety features.....	47
System lock/safety lock	47
Safety switch-off	49
Overheating protection.....	50
Programming	51
Note for test institutes	55
Cleaning and care	56
Grease filter/extraction grille.....	58
Cooker hood drip tray	59
Resetting the grease filter operating hours counter	60
Reactivating charcoal filter	60
Resetting the charcoal filter operating hours counter	60
Problem solving guide	61
Optional accessories	65
Installation.....	66
Safety instructions for installation	66
Safety distances.....	68
Installation notes	71
Surface-mounted installation	71
Flush-fit installation	72
Minimum plinth height.....	72
Drip tray.....	72
Installation examples.....	73
Installation dimensions – Surface-mounted	74
KMDA 7476 FR.....	74
Worktop depth 600 mm	76
Worktop depth greater than 600 mm	78
Installation dimensions – Flush-mounted.....	80
KMDA 7476 FL	80
Worktop depth 600 mm	81
Worktop depth greater than 600 mm	83
Extraction direction modification.....	85
Turning the extraction ducting connection clockwise	85
Turning the extraction ducting connection anticlockwise	86

Contents

Connection to window contact, if required	88
Surface-mounted installation	90
Flush-fit installation	91
Ducting	92
Electrical connection	93
After sales service	96
Contact in the event of a fault	96
Data plate	96
Warranty	96
Product data sheets	97
Conformity declaration	99

Warning and Safety instructions

This hob complies with all relevant local and national safety requirements. Inappropriate use can, however, lead to personal injury and material damage.

Read the operating and installation instructions carefully before using the hob. They contain important information on safety, installation, use and maintenance. This prevents both personal injury and damage to the hob.

In accordance with standard IEC 60335-1, Miele expressly and strongly advises that you read and follow the instructions in the chapter on installing the hob as well as the safety instructions and warnings.

Miele cannot be held liable for injury or damage caused by non-compliance with these instructions.

Keep these instructions in a safe place and pass them on to any future owner.

Warning and Safety instructions

Correct application

- ▶ This hob is intended for domestic use and use in other similar environments.
- ▶ This hob is not intended for outdoor use.
- ▶ It is intended for domestic use only to cook food and keep it warm. Any other use is not supported by the manufacturer and could be dangerous.
- ▶ This hob is not intended for use by people with reduced physical, sensory or mental capabilities or lack of experience and knowledge, unless they have been given supervision and instruction concerning its use by a person responsible for their safety. They may only use the hob unsupervised if they have been shown how to use it in a safe way. They must be able to recognise and understand the dangers of misuse.

Safety with children

- ▶ Children under 8 years of age must be kept away from the hob unless they are constantly supervised.
- ▶ Children over 8 years of age may use the hob without supervision if its operation has been clearly explained to them and they are able to use it safely. Children must be able to understand and recognise the possible dangers caused by incorrect operation.
- ▶ Children must not be allowed to clean the hob unsupervised.
- ▶ Please supervise children in the vicinity of the hob and do not let them play with it.
- ▶ The hob gets hot when in use and remains hot for a while after being switched off. Keep children well away from the hob until it has cooled down and there is no danger of burning.
- ▶ Danger of burning! Do not store anything which might arouse a child's interest in storage areas above or behind the hob. Otherwise they could be tempted into climbing onto the appliance with the risk of burning themselves.
- ▶ Risk of burning and scalding. Place pots and pans on the cooking zone in such a way that children cannot pull them down and burn themselves.
- ▶ Danger of suffocation! Whilst playing, children may become entangled in packaging material (such as plastic wrapping) or pull it over their head with the risk of suffocation. Keep packaging material away from children.
- ▶ Activate the system lock to ensure that children cannot switch on the hob inadvertently. Use the safety lock when the hob is in use to prevent children from altering the settings selected.

Warning and Safety instructions

Technical safety

- ▶ Unauthorised installation, maintenance and repairs can cause considerable danger for the user. Installation, maintenance and repairs must only be carried out by a Miele authorised technician.
- ▶ Damage to the hob can compromise your safety. Check the hob for visible signs of damage. Do not use the hob if it is damaged.
- ▶ Reliable and safe operation of this hob can only be assured if it has been connected to the mains electricity supply.
- ▶ The hob must not be connected to the inverter of an autonomous power supply such as e.g. **a solar power system**. When the hob is switched on, power surges could result in a safety switch-off. This could damage the electronic module.
- ▶ The electrical safety of this hob can only be guaranteed when correctly earthed. It is essential that this standard safety requirement is met. If in any doubt please have the electrical installation tested by a qualified electrician.
- ▶ To avoid the risk of damage to the hob, make sure that the connection data on the data plate (voltage and frequency) match the mains electricity supply before connecting it to the mains. Consult a qualified electrician if in doubt.
- ▶ Do not connect the hob to the mains electrical supply by a multi-socket adapter or extension lead. These are a fire hazard and do not guarantee the required safety of the appliance.
- ▶ For safety reasons, this hob may only be used after it has been built in.
- ▶ This hob must not be used in a non-stationary location (e.g. on a ship).

Warning and Safety instructions

▶ Never open the casing of the hob.

Touching or tampering with electrical connections or components and mechanical parts is highly dangerous to the user and can cause operational faults.

▶ While the hob is under warranty, repairs should only be undertaken by a Miele authorised service technician. Otherwise the warranty is invalidated.

▶ Miele can only guarantee the safety of the appliance when genuine original Miele replacement parts are used. Faulty components must only be replaced by Miele spare parts.

▶ The hob is not intended for use with an external timer switch or a remote control system.

▶ The hob must be connected to the electricity supply by a qualified electrician (see “Installation – Electrical connection”).

▶ If the mains connection cable is damaged, it must be replaced with a special mains connection cable by a qualified electrician (see “Electrical connection” in the “Installation” chapter).

▶ The hob must be disconnected from the mains electricity supply during installation, maintenance and repair work. Ensure that power is not supplied to the appliance until after it has been installed or until any maintenance or repair work has been carried out.

▶ Danger of electric shock. Do not use the hob if it is faulty, or if the ceramic surface is cracked, chipped or damaged in any way. Switch it off immediately. Disconnect the hob from the mains electricity supply. Contact Miele Service.

▶ If the hob is installed behind a cabinet door, do not close the door while the hob is in use. Heat and moisture can build up behind the closed door. This can result in damage to the hob, the housing unit and the floor. Do not close the door until the residual heat indicators go out.

Warning and Safety instructions

▶ In areas which may be subject to infestation by cockroaches or other vermin, pay particular attention to keeping the appliance and its surroundings clean at all times. Any damage caused by cockroaches or other vermin will not be covered by the warranty.

Warning and Safety instructions

Using at the same time as other heating appliances that depend on the air from the room

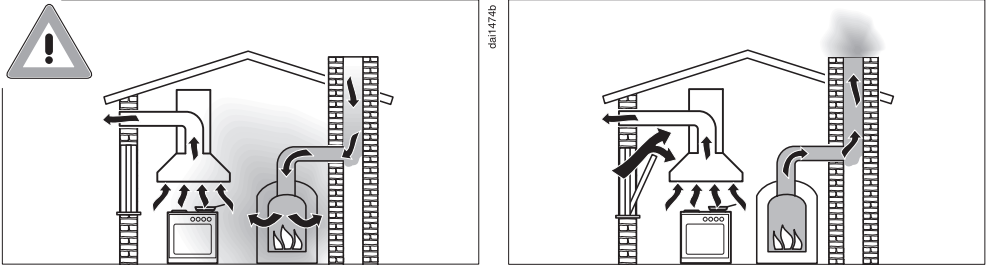

Danger of toxic fumes!

Great care should be taken when using the cooker hood in the same room or the same area of the house as another heating appliance that depends on the air from the room.

Such heating appliances draw in air from the room and duct exhaust gases out through a chimney or extraction ducting. They include gas, oil, wood and coal-fired boilers and heaters, continuous flow or other water heaters, gas hobs and ovens.

The cooker hood draws in air from the kitchen and from neighbouring rooms. This applies to the following modes of operation:

- extraction mode,
- recirculation mode with a recirculation box installed outside the room.

If there is insufficient air, an underpressure will occur. The heating appliance may be starved of oxygen. This impairs combustion. Harmful gases could be drawn from the chimney or extraction ducting back into the room, with potentially fatal consequences. Risk of death!

Warning and Safety instructions

In order to ensure safe operation and to prevent gases given off by the heating appliance from being drawn back into the room, when the cooker hood and the heater are both operated simultaneously, an underpressure in the room of 0.04 mbar (4 Pa) is the maximum permissible.

Sufficient ventilation can be maintained by air inlets which cannot be blocked, e.g. in windows, doors and outside wall vents. The diameter of the inlet openings must enable sufficient ventilation. A ventilation brick alone is not generally sufficient to ensure safe ventilation.

The overall ventilation condition of the dwelling must be taken into account. If in any doubt, the advice of a competent builder, or for gas, a qualified gas fitter should be sought.

If the cooker hood is being operated in recirculation mode, where the air is passed back into the room in which the extractor is installed, the above restrictions do not apply.

Correct use

▶ The hob gets hot when in use and remains hot for a while after being switched off. There is a danger of burning until the residual heat indicators go out.

▶ Oil and fat can overheat and catch fire. Do not leave the hob unattended when cooking with oil and fat. If it does ignite do not attempt to put the flames out with water.

Disconnect the hob from the mains and use a suitable fire blanket, saucepan lid, damp towel or similar to smother the flames.

▶ Do not leave the hob unattended whilst it is being used. It should be continually monitored whilst boiling and flash frying.

▶ Open flames are a fire hazard.

Do not flambé food. When switched on, the cooker hood could draw flames into the filter. Kitchen grease deposits could ignite.

▶ Spray canisters, aerosols and other inflammable substances can ignite when heated. Therefore do not store such items or substances in a drawer under the hob. Cutlery inserts must be heat-resistant.

▶ Do not heat an empty pan.

▶ Do not heat up food in closed containers e.g. tins or sealed jars on the hob, as pressure can build up in the container, causing it to explode.

▶ Do not cover the hob, e.g. with a hob cover, a cloth or protective foil. The material could catch fire, shatter or melt if the hob is switched on by mistake or if residual heat is still present.

▶ When the appliance is switched on either deliberately or by mistake, or when there is residual heat present, there is the risk of any metal items left on the hob heating up, with the danger of burning. Depending on the material, other items left on the hob could also melt or catch fire. Damp pan lids might adhere to the ceramic surface and be difficult to dislodge. Do not use the appliance as a resting place. Switch the cooking zones off after use.

Warning and Safety instructions

- ▶ You could burn yourself on the hot hob. Protect your hands with heat-resistant pot holders or gloves when handling hot pots and pans. Do not let them get wet or damp, as this causes heat to transfer through the material more quickly with the risk of scalding or burning yourself.
- ▶ Hot cooking vapours during cooking can cause the cooker hood to get hot.
Do not touch the casing or the grease filters until the cooker hood has cooled down.
- ▶ When using an electrical appliance, e.g. a hand-held food blender, near the hob, ensure that the cable of the electrical appliance cannot come into contact with the hot hob. The insulation on the cable could become damaged.
- ▶ Grains of salt, sugar and sand (e.g. from cleaning vegetables) can cause scratches if they get under pan bases. Make sure that the ceramic surface is clean before placing pans on it.
- ▶ Even a light object can cause damage in certain circumstances. Do not drop anything on the ceramic surface.
- ▶ Placing hot pans on the sensors and indicators could damage the electronics underneath. Do not place hot pans on the sensors or indicators.
- ▶ Do not allow solid or liquid sugar, or pieces of plastic or aluminium foil to get onto the hob when it is hot, as they can damage the ceramic surface when it cools down. If this should occur, switch off the appliance and scrape off all the sugar, plastic or aluminium residues whilst still hot, using a shielded scraper blade suitable for use on glass. Wear oven gloves when doing this. Allow the ceramic surface to cool down and then clean it with a suitable ceramic hob cleaning agent.
- ▶ Pans which boil dry can cause damage to the ceramic glass. Do not leave the hob unattended whilst it is being used.

Warning and Safety instructions

- ▶ Only use pots and pans with smooth bases. Rough bases will scratch the ceramic glass.
- ▶ Lift pans into position on the hob. Sliding them into place can cause scuffs and scratches.
- ▶ Because induction heating works so quickly, the base of the pan could, under certain circumstances, heat up to the temperature at which oil or fat self-ignites within a very short time. Never leave the hob unattended during use!
- ▶ Heat oil or fat for a maximum of one minute. Never use the Booster function to heat oil or fat.
- ▶ For people fitted with a heart pacemaker: Please note that the area immediately surrounding the hob is electromagnetically charged. It is very unlikely to affect a pacemaker. However, if in any doubt, consult the manufacturer of the pacemaker or your doctor.
- ▶ To prevent damage to items which are susceptible to electromagnetic fields, e.g. credit cards, digital storage devices, pocket calculators, etc, do not leave them in the immediate vicinity of the hob.
- ▶ Metal utensils stored in a drawer under the hob can become hot if the appliance is used intensively for a long time.
- ▶ The hob is fitted with a cooling fan. If a drawer is fitted directly underneath the hob, ensure that there is sufficient space between the drawer and its contents and the underside of the hob in order to ensure sufficient ventilation for the hob.
- ▶ If a drawer is fitted directly underneath the hob, do not store any pointed or small items, paper, serviettes, etc. in the drawer. They could get in through the ventilation slots or be sucked into the casing by the fan and damage the fan or impair cooling.
- ▶ Never use two pans on a cooking zone, extended zone or Power-Flex zone at the same time.

Warning and Safety instructions

- ▶ If the cookware only partially covers a cooking or extended zone, the handle could become very hot.
Always place cookware in the middle of a cooking or extended zone!
- ▶ Only use the PowerFlex cooking area for rectangular or oval oven dishes.
- ▶ Deposits of grease and dirt will prevent the cooker hood from working properly.
Do not use the cooker hood without the grease filters in place. Otherwise cooking vapours will not be cleaned.
- ▶ There is a risk of fire if cleaning is not carried out as described in these operating instructions.
- ▶ Do not cover the intake grille on the cooker hood when in use.
- ▶ Do not place hot pans on the extraction grille of the cooker hood. This will impair the function of the cooker hood and may damage the extraction grille.
- ▶ Liquids can damage the cooker hood if they get into it. Keep liquids away from the cooker hood.
- ▶ Light objects can be drawn into the cooker hood and impair its operation. Do not place any light objects (e.g. paper towels) within close proximity of the cooker hood.
- ▶ The induction generators could be damaged or even destroyed if you use an induction adapter plate for cookware. Do not use induction adapter plates.

Cleaning and care

- ▶ Do not use a steam cleaning appliance to clean this hob. The steam could reach electrical components and cause a short circuit.
- ▶ If the hob is built in over a pyrolytic oven, the hob should not be used whilst the pyrolytic process is being carried out, as this could trigger the overheating protection mechanism on the hob (see relevant section).

Accessories

- ▶ Only use genuine original Miele accessories and spare parts with this appliance. Using accessories or spare parts from other manufacturers will invalidate the warranty and Miele cannot accept liability.
- ▶ Miele will guarantee to supply functional spare parts for a minimum of 10 years and up to 15 years following the discontinuation of your hob.

Caring for the environment

Disposal of the packing material

The packaging is designed to protect the appliance from damage during transportation. The packaging materials used are selected from materials which are environmentally friendly for disposal and should be recycled.

Recycling the packaging reduces the use of raw materials in the manufacturing process and also reduces the amount of waste in landfill sites.

Disposing of your old appliance

Electrical and electronic appliances often contain valuable materials. They also contain specific materials, compounds and components, which were essential for their correct function and safety. These could be hazardous to human health and to the environment if disposed of with your domestic waste or if handled incorrectly. Please do not, therefore, dispose of your old appliance with your household waste.



Please dispose of it at your local community waste collection / recycling centre for electrical and electronic appliances, or contact your dealer or Miele for advice. You are also responsible for deleting any personal data that may be stored on the appliance being disposed of. Please ensure that your old appliance poses no risk to children while being stored prior to disposal.

Hob

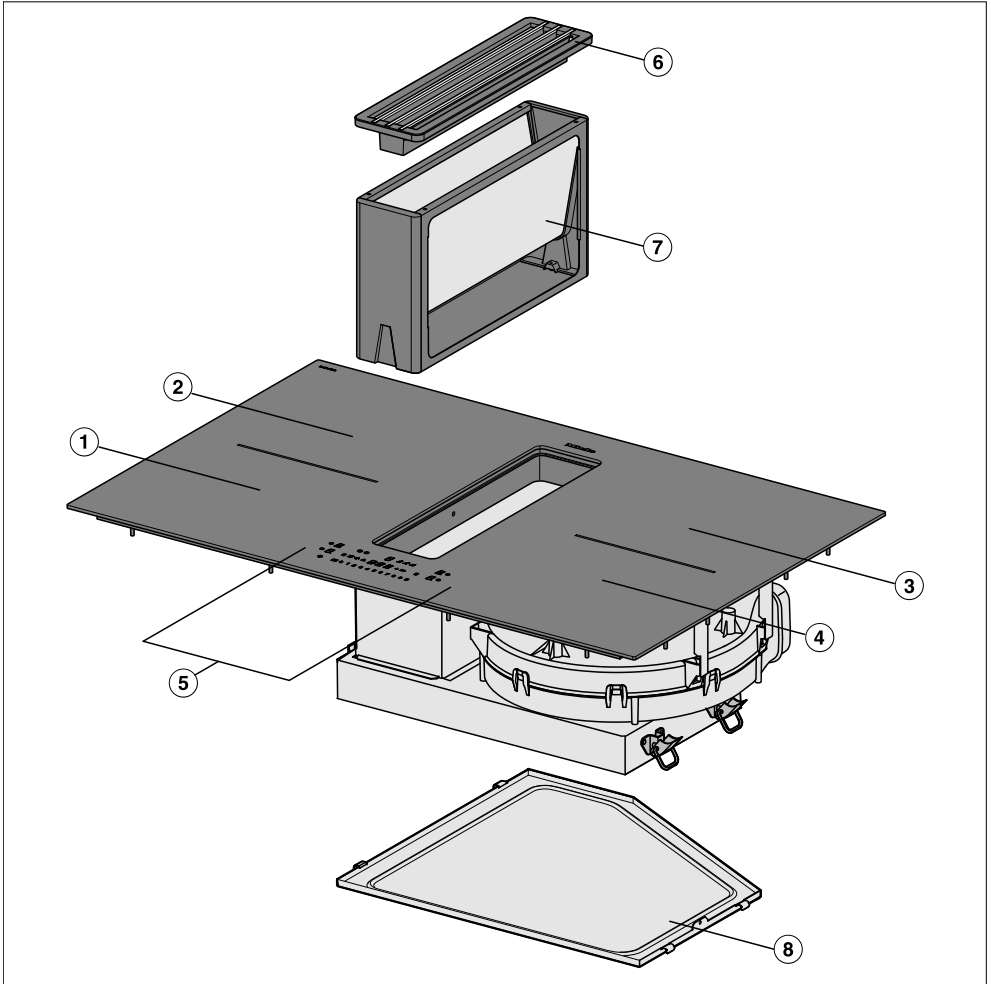

① PowerFlex XL cooking zone

② PowerFlex XL cooking zone

①② Can be combined to form a PowerFlex XL cooking area

③ PowerFlex XL cooking zone

④ PowerFlex XL cooking zone

③④ Can be combined to form a PowerFlex XL cooking area

⑤ Control elements/indicators

⑥ Cover grille

⑦ Grease filter

⑧ Removable drip tray

Guide to the appliance

Controls / Indicators

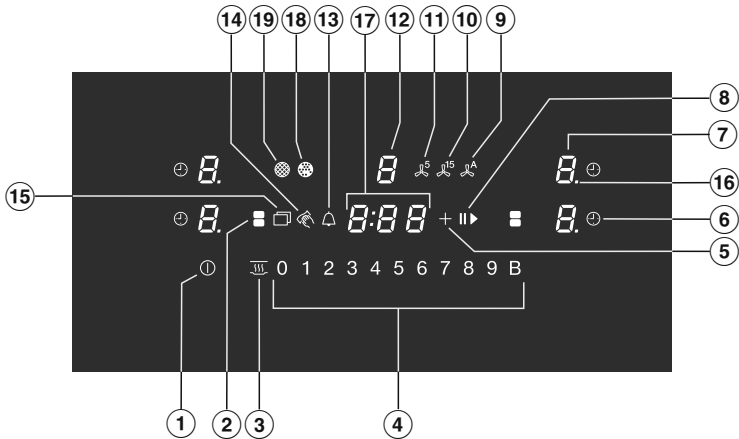

Sensor controls

- ① For switching the hob on/off
- ② For switching PowerFlex cooking zones on together/separately
- ③ Activating/deactivating the Keeping warm function
- ④ Numerical display
 - For setting the power level
 - For setting the timer
- ⑤ Plus for timer input and settings in the programming mode
- ⑥ Switching off a cooking zone automatically
- ⑦ Cooking zone selection and display

	Cooking zone ready for use
<i>h</i>	Keep-warm setting
<i>1</i> to <i>9</i>	Power level
<i>,</i>	TwinBooster level 1
<i>,,</i>	TwinBooster level 2
	No pan on cooking zone or pan unsuitable (see “Pans” in the “Induction” chapter)
	Residual heat
<i>R</i>	Auto heat-up

- ⑧ Stop & Go

- ⑨ Automatic vapour extraction
- ⑩ 15 minute run-on option
- ⑪ 5 minute run-on option
- ⑫ Selection and display of vapour extraction
 - 0* Vapour extraction ready for operation
 - 1 to 3* Power level
(can be extended to 9 settings, see “Programming”)
 - 8* Booster function
- ⑬ Minute minder
- ⑭ Wipe protection
- ⑮ Menu

Displays/indicator lights

- ⑯ Extended power level range setting
- ⑰ Timer display
 - 0:00 to 9:59* Time
 - LOC* System lock/safety lock activated
 - dE* Demonstration mode activated
- ⑱ Clean grease filter
- ⑲ Clean charcoal filter

Guide to the appliance

Cooking zones

Cooking zone	Size in cm		Max. rating in watts for 230 V ³	Linked cooking zone ⁴	
	∅ ¹	 ²			
①	15–23	23 x 23	Normal TwinBooster, level 1 TwinBooster, level 2	2100 3000 3650	③
②	15–23	23 x 23	Normal TwinBooster, level 1 TwinBooster, level 2	2100 3000 3650	④
③	15–23	23 x 23	Normal TwinBooster, level 1 TwinBooster, level 2	2100 3000 3650	①
④	15–23	23 x 23	Normal TwinBooster, level 1 TwinBooster, level 2	2100 3000 3650	②
① + ② ③ + ④	–	23 x 46	Normal TwinBooster, level 1 TwinBooster, level 2	3400 4800 7300	–
			Total	7300	

- 1 Cookware with a base diameter within the given range may be used.
- 2 The given range corresponds to the maximum base surface of the cookware that may be used.
- 3 The wattage quoted may vary depending on the size and material of the cookware used.
- 4 The cooking zone is linked to this cooking zone electrically so that the rating can be increased; see “Operation – Power management”.

Before using for the first time

- Please stick the extra data plate for the appliance supplied with this documentation in the space provided in the “After sales service” section of this booklet.
- Remove any protective wrapping and stickers.

Cleaning the hob for the first time

- Before using for the first time, clean the hob with a damp cloth only and then wipe dry.

Switching on the hob for the first time

The metal components have a protective coating which may give off a slight smell when heated up for the first time. The induction coils may also give off a slight smell for the first few hours of operation. This smell will be less noticeable with each subsequent use before dissipating completely.

The smell and any vapours given off do not indicate a faulty connection or appliance and they are not hazardous to health.

Please note that the heating up time on induction hobs is very much shorter than on conventional hobs.

Before using for the first time

Miele@home

Prerequisite: home WiFi network

Your hob is equipped with an integrated WiFi module. The hob can be connected to your home WiFi network.

Make sure that the signal of your WiFi network is sufficiently strong in the place where your hob is installed.

There are a number of ways of connecting your hob to your WiFi network.

The hob requires max. 2 W in networked standby.

Availability of the WiFi connection

The WiFi connection shares a frequency range with other appliances (including microwave ovens and remote control toys). This can give rise to sporadic or even complete connection failures. Therefore, the availability of featured functions cannot be guaranteed.

Miele@home availability

The ability to use the Miele app depends on the availability of the Miele@home service in your country.

The Miele@home service is not available in every country.

For information about availability, please visit www.miele.com.

Miele App

The Miele App is available to download free of charge from the Apple App Store® or from the Google Play Store™.



After installing the Miele app on a mobile device, you can do the following:

- Call up information on the operating status of your hob
- Call up information on the programme sequence of your hob
- Set up a Miele@home network with other WiFi-enabled Miele appliances

Before using for the first time

Setting up Miele@home

Connecting via the app

The Miele app can be used to connect to your network.

To connect, you will need:

1. Your WiFi network password
2. The password for your hob

The password for your hob consists of the last 9 digits of the serial number. This can be found on the appliance's data plate.

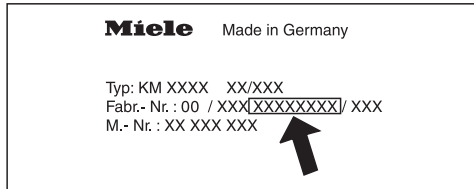

- Install the Miele app on your mobile device.
- Start the Miele app.
- Switch the hob on.
- Touch any cooking zone display.
- Touch the 0 and 5 sensor controls at the same time for 6 seconds.

The seconds can be seen counting down in the timer display. After the time has elapsed, the code `⌚:01` is displayed in the timer display for 10 seconds.

You now have 10 minutes to configure the WiFi.

- Follow the user navigation in the app.

Connecting via WPS

Prerequisite: you must have a WPS (WiFi protected setup) compatible router.

- Switch the hob on.
- Touch any cooking zone display.
- Touch the 0 and 6 sensor controls at the same time for 6 seconds.

The seconds can be seen counting down in the timer display. After the time has elapsed, a progress light appears during the connection attempt (for max. 120 seconds).

The WPS login is only active during these 120 seconds.

- Activate the WPS function on your WiFi router.

If the connection was successful, the code `⌚:02` appears in the timer display. If the connection could not be established, the timer display will show the code `⌚:01`. You have probably not activated WPS on your router quickly enough. Repeat the steps above.

Tip: If your WiFi router does not support WPS, please connect via the Miele app.

Before using for the first time

Cancelling the process

- Touch the ① sensor control.

Resetting settings

Resetting is not required when replacing the router.

- Switch the hob on.
- Touch any cooking zone display.
- Touch the 0 and 9 sensor controls at the same time for 6 seconds.

The seconds can be seen counting down in the timer display. After the time has elapsed, the code $\text{E:}00$ is displayed in the timer display for 10 seconds.

Reset the settings if you are disposing of your hob, selling it or putting a used hob into operation. This is the only way to ensure that all personal data has been removed and the previous owner will no longer be able to access the hob.

How it works

An induction coil is located under each induction cooking zone. The coil creates a magnetic field that reacts directly with the base of the pan and heats it up. The cooking zone itself is heated up indirectly by the heat given off by the pan.

An induction cooking zone only works when a pan with a magnetic base is placed on it (see “Pans”). Induction automatically recognises the size of the pan.



Risk of burning due to hot items.

When the appliance is switched on either deliberately or by mistake, or when there is residual heat present, there is the risk of metal items placed on the hob heating up.

Do not use the appliance as a resting place for anything.

After use, switch the hob off with the  sensor control.

Pans

Suitable pans

- stainless steel pans with a magnetic base
- enamelled steel pans
- cast iron pans

Please be aware that the properties of the pan base can affect the evenness with which the food heats up (e.g. when making pancakes). The base of the pan must be able to distribute the heat evenly. A sandwich base made of stainless steel is particularly suitable.

Unsuitable pans.

- stainless steel pans without a magnetic base
- aluminium or copper pans
- glass, ceramic or earthenware pots and pans

Testing pans

To test whether a pan is induction-compatible, hold a magnet to the base of the pan. If the magnet sticks, the pan is generally suitable.

Induction

No pan/unsuitable pan display

The \cup symbol flashes alternately with the power level selected in one of the cooking zone displays

- if the cooking zone has been switched on without a pan in place, or if the pan is unsuitable (non-magnetic base)
- if the diameter of the base of the pan is too small
- if the pan is taken off the cooking zone when it is switched on

If a suitable pan is placed on the cooking zone within 3 minutes, \cup will go out and you can continue as normal.

If no pan or an unsuitable pan is placed on the cooking zone, the cooking zone will switch off automatically after 3 minutes.

Tips

- To make optimum use of the cooking zones, choose cookware with a suitable base diameter (see “Overview – Cooking zone data”). If the pan is too small it will not be recognised.
- Position the cookware as centrally as possible on the relevant cooking zone/cooking area.
- Use only pots and pans with smooth bases. Rough bases can scratch the ceramic glass.
- Always lift cookware to move it. This will help prevent scratching. If any scratches do appear as a result of cookware being pushed around, this will not affect the function of the hob. These scratches are normal signs of use and are not grounds for making a complaint.
- Please note that the maximum diameter quoted by manufacturers often refers to the diameter of the top rim of the pots and pans. The diameter of the base (generally smaller) is more important.



- Where possible, use pans with vertically straight sides. If a pan has angular sides, induction also acts on the sides of the pan. The sides of the pan may discolour or the coating may peel off.

Power management

The hob has a maximum total permitted power consumption which cannot be exceeded for safety reasons. You can lower the maximum total permitted power consumption, see “Programming”.

Cooking zones can be linked together in pairs on the hob. This allows additional power to be transferred from one cooking zone to another.

The previously set setting has precedence and the hob will operate with this level.

If power is transferred from one cooking zone to the linked cooking zone, the power for the first cooking zone must be reduced.

The possible values for the maximum total permitted power consumption and which cooking zones are linked together can be found in “Overview – Cooking zone data”.

If the new cooking zone requires more power than the first cooking zone can provide, this may result in the following consequences for the first cooking zone:

- The power level is reduced.
- Auto heat-up is deactivated. Cooking continues at the set level. If the power is not sufficient, the power level will be reduced again.
- The Booster function is deactivated.
- The cooking zone is switched off.

If the most recently set power level is reduced or the Booster function is switched off, the power level for the linked cooking zone can be increased again.

Induction

Noises

When using an induction hob, the following noises can occur in the pan, depending on what it is made of and how it has been constructed.

Buzzing on the higher power settings. This will decrease or cease altogether when the power setting is reduced.

If the pan base is made of layers of different materials (e.g. in a sandwiched base), it might emit a crackling sound.

Whistling might occur if linked zones (see “Operation - Booster”) are being used at the same time, and the pans also have bases made of layers of different materials.

You might hear a clicking sound from the electronic switches, especially on lower settings.

A whirring sound, when the cooling fan comes on. This switches on to protect the electronics when the hob is being used intensively. The cooling fan may continue to run after the appliance has been switched off.

How the vapour extraction works

The exhaust air drawn into the cooker hood must not be routed into the base unit. This will damage the unit.

Extraction mode



The air drawn in is cleaned by the grease filter and directed outside through a ventilation gap. The necessary accessories are available from Miele.

Recirculation mode

The air is drawn in and cleaned by the grease filter. The air is then directed into the recirculation box where it is also cleaned by a charcoal filter. The cleaned air is then recirculated back into the kitchen. The necessary accessories are available from Miele.

Operating hours counter

The number of hours that the cooker hood has been used for is stored in memory.

When the grease filter symbol  or the charcoal filter symbol , lights up, the operating hours counters are signalling that the filters need to be cleaned or changed. Further information about cleaning and changing the filters and resetting the operating hours counter can be found under “Cleaning and care”.

The instruction manual supplied with the recirculation box states that the operating hours counter for the charcoal filter needs to be activated. This is not necessary here.

The charcoal filter system  also appears when the appliance is operated using extraction mode.

Tips on saving energy

- Use a lid whenever possible to minimise heat loss.
- Select a smaller pan when cooking small quantities. A smaller pan uses less energy than a larger pan with very little in it.
- Cook with as little water as possible.
- Once food has come to the boil or the oil in the pan is hot enough for frying, reduce the heat to a lower setting.
- Use a pressure cooker to reduce cooking times.
- It is important to ensure that the kitchen is well ventilated during operation. In extraction mode if there is insufficient air flow, the cooker hood cannot operate efficiently and this causes increased operating noise levels.
- Always cook with the lowest possible setting. This produces fewer cooking vapours, so you can use a lower power level and therefore benefit from reduced energy consumption.
- Check the power level on the cooker hood. A low power level is usually sufficient. Only use the Booster setting when necessary.
- When a large volume of cooking vapours are being produced, switch to a high power level in good time. This is more efficient than operating the cooker hood for longer to try to capture cooking vapours which have already been distributed throughout the kitchen.
- Switch the cooker hood off after cooking.
- Clean or replace the filters at regular intervals. Heavily soiled filters reduce performance, increase the risk of fire and are unhygienic.

Setting ranges

The hob is programmed with 9 power levels at the factory. If you wish to fine-tune a setting, you can extend the power level range to 17 power levels (see “Programming”).

	Setting range	
	Factory setting (9 power levels)	Extended setting (17 power levels)
Melting butter Melting chocolate Dissolving gelatine	1–2	1–2.
Warming up small quantities of liquid Keeping warm food which sticks easily Cooking rice or porridge Defrosting vegetables frozen in a block	2–4	2–3.
Warming up liquid and semi-solid food Steaming fruit Simmering potatoes (pans with lids)	4–6	3.–5.
Making omelettes or lightly fried eggs Gently frying meat patties Steaming fish and vegetables Cooking dumplings and dried pulses Defrosting and reheating frozen food Thickening sauces, e.g. Hollandaise	5–7	4.–7.
Gently frying fish, escalopes, sausages, fried eggs (without overheating the fat)	6–8	6–7.
Cooking potato fritters, pancakes, etc.	7–8	7–8.
Boiling large quantities of water Bringing to the boil Flash frying large amounts of meat	9	8.–9

These settings should only be taken as a guide. The power of the induction coils will vary depending on the pan base size and material and the positions of the pans on the hob. For this reason, it is possible that the power levels will need to be adjusted slightly to suit your pans. As you use the hob, you will get to know which settings suit your pans best. When using new pans that you are not familiar with, set the power level below the one specified.

Operation

Using the appliance

This ceramic glass hob is equipped with electronic sensor controls which react to finger contact. For safety reasons, in order to switch the appliance on, the On/Off ① sensor control needs to be touched for a little longer than the other sensors.

Each time a sensor control is activated, an audible signal sounds.

Only the printed On/Off ① symbol is visible when the hob is switched off. More sensors light up when the hob is switched on.

In order to set or alter a power level, the cooking zones must be “active”. To activate a cooking zone, touch the display for the relevant cooking zone. The relevant cooking zone display will appear brighter when touched. While the display is brighter, the cooking zone is “active” and you can set a power level or time.

Exception: if only one of the cooking zones is in operation, you can alter the power level without activating the cooking zone.

 Malfunction due to dirty and/or covered sensor controls.

If the sensor controls are dirty or covered this could cause them to fail to react, to activate a function or even to switch the appliance off automatically (see “Safety features”, “Safety switch-off”). Placing hot pans on the sensor controls/indicators can damage the electronic unit underneath.

Keep the sensor controls and indicators clean.

Do not place anything over the sensor control or indicators.

Do not place hot pans over the sensor controls or indicators.

 Risk of fire with overheated food. Unattended food can overheat and catch alight. Do not leave the hob unattended whilst it is being used.

Please note that the heating up time on induction hobs is very much shorter than on conventional hobs.

Switching on the hob

- Touch the ① sensor.

Other sensors will light up.

If no further entry is made, the hob will switch itself off after a few seconds for safety reasons.

Setting the power level

Permanent pan recognition is activated as standard (see “Programming”). When the hob is switched on and you place an item of cookware on one of the cooking zones, all the sensors for that cooking zone’s numerical display will light up.

- Place the cookware on the cooking zone you want to use.
- Touch the appropriate sensor control on the numerical display for the power level you want.

Changing the power level

- Touch the relevant cooking zone display.

The cooking zone display appears brighter.

- Touch the appropriate sensor control on the numerical display for the power level you want.

Switching off a cooking zone/ the hob

Switching off a cooking zone

- Touch and hold the relevant cooking zone display until the cooking zone switches off.

or

- Touch the relevant cooking zone display.

The cooking zone display appears brighter.

- Touch the 0 sensor control on the numerical display.

Switching the hob off

- To switch off the hob and all the cooking zones, touch the ① sensor control.

Operation

Residual heat indicator

If a cooking zone is hot, the residual heat indicator will light up after it has been switched off or if it is not in use.

The bars of the residual heat indicator go out one after the other as the cooking zone cools down. The last horizontal bar only goes out when the cooking zone is safe to touch.



Risk of burning due to hot cooking zones.

The cooking zones will be hot after use.

Do not touch the cooking zones while the residual heat indicators are on.

Setting the power level – extended setting range

- Touch the numerical display in between two number sensors.

A dot appears after the power level in the cooking zone selection.

The sensor controls to the left of the interim level light up brighter than the other sensor controls.

Example:

If you have set power level 7., the cooking zone selection will show 7..

The number 7 on the numerical display will light up brighter than the other sensor controls.

PowerFlex XL cooking area

The PowerFlex XL cooking zones combine automatically to form a PowerFlex XL cooking area when you place a sufficiently large item of cookware on them (see “Overview – Hob”). You can also link or unlink the PowerFlex XL cooking zones manually:

- Touch the  sensor control.

Positioning cookware

Refer to the cooking zone data for your hob model for information about cookware sizes and the corresponding positions (see “Overview – Cooking zone data”).

PowerFlex XL cooking zone

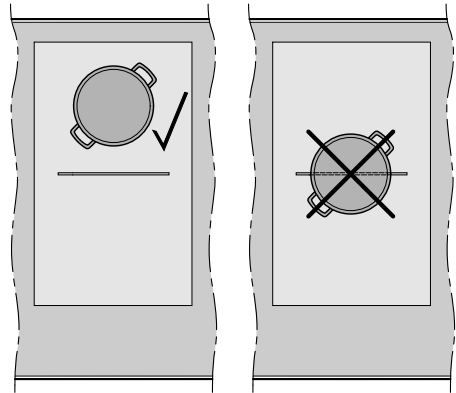

PowerFlex XL cooking area (oven dish)

Oven dishes with a base length of less than 25 cm may not be detected by the cooking area.

Place oven dishes of this size on an individual cooking zone.

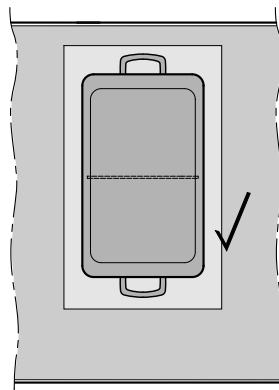

Operation

Auto heat-up

When Auto heat-up has been activated, the cooking zone switches on automatically at the highest setting and then switches to the continued cooking setting which you have previously selected. The heat-up time depends on which continued cooking setting has been chosen (see chart).

Activating Auto heat-up

- Briefly touch the display for the required cooking zone.
- Touch the sensor for the continued cooking setting you want until a tone sounds and *H* lights up in the cooking zone display.

The *H* symbol flashes alternately with the power setting selected in the cooking zone display during the heat-up time (see chart).

Changing the continued cooking setting while the cooking zone is heating up deactivates Auto heat-up.

Deactivating Auto heat-up

- Touch the sensor for the continued cooking setting.
- or
- Set another power level.

Continued cooking setting*	Heat-up time [min : sec]
1	Approx. 0:15
1.	Approx. 0:15
2	Approx. 0:15
2.	Approx. 0:15
3	Approx. 0:25
3.	Approx. 0:25
4	Approx. 0:50
4.	Approx. 0:50
5	Approx. 2:00
5.	Approx. 5:50
6	Approx. 5:50
6.	Approx. 2:50
7	Approx. 2:50
7.	Approx. 2:50
8	Approx. 2:50
8.	Approx. 2:50
9	—

* The continued cooking settings with a dot after the number are only available if the power level range has been extended (see "Programming").

Booster function

The cooking zones are equipped with a TwinBooster.

When the Booster function is activated, the power is boosted so that large quantities can be heated up quickly, e.g. when boiling water for cooking pasta. The boost in power is active for a maximum of 15 minutes.

When the Booster function is activated, the settings for active cooking zones may be changed, see “Induction – Power management”.

The Booster function can be used on a maximum of 2 cooking zones or 1 PowerFlex cooking area at the same time.

If the Booster function is switched on when

- no power level has been selected, the cooking zone will revert automatically to level 9 at the end of the Booster time or if the Booster function is switched off before this.
- a power level has been selected, the cooking zone will revert automatically to the power level selected at the end of the Booster time or if the Booster function is switched off before this.

Activating the TwinBooster

Level 1

- Place the cookware on the cooking zone you want to use.
- Select a power level if necessary.
- Touch the **B** sensor control.

, will appear in the cooking zone display.

Level 2

- Place the cookware on the cooking zone you want to use.
- Select a power level if necessary.
- Touch the **B** sensor control twice.

// will appear in the cooking zone display.

Deactivating TwinBooster

- Touch the **B** sensor control repeatedly until the indicator lights go out.

or

- Set another power level.

Operation

Keeping warm

This function is for keeping food warm which has just been cooked and is still hot. It is not for reheating food that has gone cold.

The maximum duration for keeping food warm is 2 hours.

- Only use pans for keeping food warm. Cover the pan with a lid.
- Stir firm or viscous food (mashed potatoes, stew) occasionally.
- Nutrients are lost when food is cooked, and continue to diminish when food is kept warm. The longer food is kept warm, the greater the loss of nutrients. Try to ensure that food is kept warm for as short a time as possible.

Activating/deactivating the Keeping warm function

- Touch the cooking zone display for the required cooking zone.
- Touch the  sensor control.

Vapour extraction

The vapour extraction will switch itself on automatically if there is an item of cookware on a cooking zone and a power level has been set for that zone (Con@ctivity). The power level for vapour extraction is set to suit the power level of the cooking zone.

You can deactivate Con@ctivity temporarily or permanently. To deactivate Con@ctivity permanently, see “Programming”. If Con@ctivity is permanently deactivated, the  sensor control will no longer be illuminated.

The power level of the vapour extraction can be manually altered at any time. Power levels 1 to 3 and a Booster level are set as standard. The power levels can be extended to 1 to 9 and a Booster level, see “Programming”.

For light to heavy cooking vapours and odours, select from power levels **1** to **3** (9 with the extended power levels). For short periods of very strong vapours and odours, e.g. whilst searing meat, select the **B** Booster setting.

If the cooker hood starts with power level 1, the power is automatically increased to level 2 for 20 seconds. This automatic function is necessary in order to ensure that the flap opens in extraction mode. If you are using the cooker hood in recirculation mode, you can deactivate this automatic function, see “Programming”.

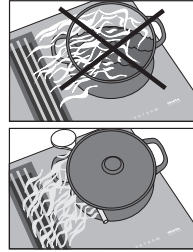

Tip: To help release vapours effectively with pans over 15 cm high, place a wooden spoon between the lid and the pan.

Operation

Setting the power level/Switching off vapour extraction

- Touch the vapour extraction display.
- To switch the fan on touch the appropriate sensor for the power level you want.
- To switch the fan off touch the **0** sensor.

If the vapour extraction is not switched off manually, it will switch itself off automatically 12 hours after last being used.

Deactivating Con@ctivity temporarily

The vapour extraction has switched on automatically.

- You can deactivate Con@ctivity in various ways:
 - Touch the  sensor control
 - Touch the **0** sensor control
 - Select a different power level
- Set the power level you want.

Depending on the programming, Con@ctivity will be reactivated when you switch the hob off and back on again, see “Programming”.

If you want to deactivate Con@ctivity permanently, you will need to change the Con@ctivity programming, see “Programming”.

Booster

The maximum duration for the Booster is 10 minutes.





- To switch it off early, set a different power level.

Run-on time

It is advisable to run the fan for a few minutes after cooking has finished. This helps to neutralise any lingering vapours and odours in the air. The following two options are available:

⁵ (5 minutes) and ¹⁵ (15 minutes).

The run-on duration will be carried out using the power level set during activation. You can change the power level during the run-on period.

- Touch the ⁵ or ¹⁵ sensor to activate the run-on period.
- Touch the ⁵, ¹⁵ or **0** sensor to deactivate the run-on period.

If you switch the hob off with the  sensor, the run-on period will continue through to the end.

The hob has to be switched on if you want to use the timer.

A duration of between 1 minute (0:01) and 9 hours 59 minutes (9:59) can be set.

Durations of up to 59 minutes are shown in minutes (0:59) and durations of more than 60 minutes are shown in hours and minutes. Durations are entered in the order of hours, followed by minutes in tens and then units.

Example:

59 minutes = 0:59, touch: 5-9

80 min = 1:20, touch: 1-2-0

After the first number has been entered, the timer display will light up constantly. After the second number has been entered, the first number will move to the left. After the third number has been entered, the first and second numbers will move to the left.

The timer can be used for the following 2 functions:

- For setting the minute minder
- For automatically switching a cooking zone off



The functions can be used at the same time. The timer for the most recently selected cooking zone is always displayed.

Touch the  sensor control or the relevant cooking zone display if you want to show the times left counting down in the background.

Minute minder

The minute minder is set using the numerical display.

Setting the minute minder

- Touch the  sensor control.
- Touch the  sensor control.

The timer display starts flashing.

- Set the required duration.

Touch the  sensor control or wait 10 seconds to start the minute minder.

Changing the minute minder duration

- Touch the  sensor control.

The timer display starts flashing.

- Set the required duration.

Deleting the minute minder duration

- Touch the  sensor control repeatedly until 0:00 appears in the timer display.

Timer

Switching off a cooking zone automatically

You can set a time after which a cooking zone will switch off automatically. This function can be used for all cooking zones at the same time.

If the time programmed is longer than the maximum operating time allowed, the cooking zone will be switched off by the safety switch-off function (see “Safety features – Safety switch-off”).

- Select a power level for the cooking zone you require.
- Touch the  sensor control.

The timer display starts flashing.

- Set the required duration.

Touch the  sensor control or wait 10 seconds to start the switch-off time.

- If you want to set another cooking zone to switch off automatically, follow the same steps as described above.

If multiple switch-off times are programmed, the timer for the most recently selected cooking zone is displayed.

Changing the switch-off time

- Touch the relevant cooking zone display.
- Touch the  sensor control.

The timer display starts flashing.

- Set the required duration.

Deleting the switch-off time

- Touch and hold the  sensor control for the relevant cooking zone until the switch-off time disappears.

or

- Touch the  sensor control for the relevant cooking zone.

The timer display starts flashing.

- Touch the 0 sensor control on the numerical display.

Stop & Go

When Stop & Go is activated, the power of all cooking zones in use is reduced to power level 1. The power level of the vapour extraction is not reduced. Depending on the power level set for the cooking zones, it may even increase. The cooking zone power levels and the timer settings cannot be altered; the hob can only be switched off. The minute minder, switch-off, Booster and heat-up times continue to run.

When Stop & Go is deactivated, the cooking zones will operate at the power level previously selected.

If the function is not deactivated within 1 hour, the hob will switch off.

Activating

- Touch the  sensor control.
- Touch the  sensor control.

Deactivating

- Touch the  sensor control.

Use this function if there is a danger of food boiling over.

Recall

If the hob is switched off by mistake during use, this function can be used to reset all settings. For this to work, the hob must be switched on again within 10 seconds of being switched off.



- Switch the hob on again.
- Immediately after switching the hob on, touch one of the flashing cooking zone displays.

Additional functions

Wipe protection

The hob sensor controls can be locked for 20 seconds, e.g. to remove soiling. The ① sensor control is not locked.

Activating

- Touch the  sensor control.
- Touch the  sensor control.

The time counts down in the timer display.

Deactivating

- Touch the  sensor control until the timer display goes out.

Demo mode

These functions enable the hob to be demonstrated in showrooms without heating up.

Activating/deactivating demo mode

When this mode is set, the hob can be operated as normal.

- Switch the hob on.
- Place an induction-compatible item of cookware on the hob.
- Touch and hold the 0 and 2 sensor controls on the numerical display at the same time for 6 seconds.

In the timer display, *dE* flashes alternately with *0n* (demo mode activated) or *0FF* (demo mode deactivated) for a few seconds.

Displaying hob data

The model number and software version of the hob can be displayed.

Model number/serial number

- Switch the hob on.
- Place an induction-compatible pan on the hob.
- Touch and hold the 0 and 4 sensor controls on the numerical display at the same time.

Numbers will appear in the timer display one after another, separated by a dash.

Example: *12 34* (model number KM 1234) – *1 23 45 67 89* (serial number)

Software version

- Switch the hob on.
- Place an induction-compatible pan on the hob.
- Touch and hold the 0 and 3 sensor controls on the numerical display at the same time.

Numbers appear in the timer display:

Example: *2:00* = software version 2.00

System lock/safety lock

The safety lock function is deactivated if there is a mains outage.

Your hob is equipped with a system lock and a safety lock to prevent the hob, cooking zones and vapour extraction being switched on inadvertently or any settings being altered.

The **system lock** is activated when the hob is switched off. If the system lock is activated, the hob cannot be switched on and the timer cannot be used. A set minute minder time continues to count down. The hob is programmed so that the system lock must be activated manually. It can be programmed to be activated automatically 5 minutes after the hob has been switched off (see “Programming”).

The **safety lock** is activated when the hob is switched on. When the safety lock is activated, the hob can be operated only under certain conditions:

- The cooking zones, the vapour extraction and the hob can only be switched off.
- The  sensor control can be activated.
- A set minute minder time can be modified.

If an unavailable sensor control is touched whilst the system lock or safety lock is activated *LDC* will appear in the timer display for a few seconds and a tone will sound.

Activating the system lock

- Touch the  sensor for 6 seconds.

The seconds can be seen counting down in the timer display. When this time has elapsed *LDC* will appear in the timer display. The system lock has been activated.



Deactivating the system lock

- Touch the  sensor for 6 seconds.

LDC will appear briefly in the timer display and then the seconds will be seen counting down. The system lock is deactivated once the time has elapsed.



Safety features

Activating the safety lock

- Touch the  sensor control.
- Touch and hold the  and  sensor controls at the same time for 6 seconds.

The seconds can be seen counting down in the timer display. When this time has elapsed *LDC* will appear in the timer display. The safety lock is activated.

Deactivating the safety lock

- Touch and hold the  and  sensor controls at the same time for 6 seconds.

LDC will appear briefly in the timer display and then the seconds will count down. Once the time has elapsed, the safety lock function is deactivated.

Safety switch-off

Sensor controls are covered

Your hob will turn off automatically if one or several of the sensors remain covered for longer than 10 seconds, for example, by finger contact, food boiling over or by an object such as an oven glove or tea towel. \mathcal{L} will flash briefly in the timer display and a tone will sound. \mathcal{L} will go out once you have removed the object and/or cleaned the hob and the hob will be ready to use again.

Excessive operating time

The safety switch-off mechanism is triggered automatically if a cooking zone is heated for an unusually long period of time. This time depends on the power level selected. If it has been exceeded, the cooking zone switches off and the residual heat indicator appears. If you switch the cooking zone on and off again, it is ready for operation again.

The hob is programmed to safety setting 0 at the factory. If necessary, a higher safety setting with a shorter maximum operating time can be set (see chart).

Power level*	Maximum operating time [h:min]		
	Safety setting		
	0**	1	2
1	10:00	8:00	5:00
1.	10:00	7:00	4:00
2/2.	5:00	4:00	3:00
3/3.	5:00	3:30	2:00
4/4.	4:00	2:00	1:30
5/5.	4:00	1:30	1:00
6/6.	4:00	1:00	0:30
7/7.	4:00	0:42	0:24
8	4:00	0:30	0:20
8.	4:00	0:30	0:18
9	1:00	0:24	0:10

* The power levels with a dot after the number are only available if the power level range has been extended (see "Setting range").

** Factory default setting

Safety features

Overheating protection

All the induction coils and cooling elements for the electronics are fitted with an overheating protection mechanism. Before the induction coils and/or cooling elements get too hot, the overheating protection mechanism cuts in in one of the following ways:

Induction coils

- Any Booster function in operation will be switched off.
- The set power level will be reduced.
- The cooking zone turns off automatically. *Err* will flash alternately with *044* in the timer display.

You can use the cooking zone again as usual when the fault code has gone out.

Cooling elements

- Any Booster function in operation will be switched off.
- The set power level will be reduced.
- The cooking zones switch off automatically.

The affected cooking zones can only be used again as usual once the cooling element has cooled down to a safe level.

The overheating protection may be activated under the following circumstances:

- The pan being heated is empty.
- Fat or oil is being heated on a high power level.
- There is insufficient ventilation to the underside of the hob.
- A hot cooking zone is switched on after an interruption to the power supply.

If, despite removing the cause, the overheating protection mechanism triggers again, contact the Customer Service Department.

You can adapt the programming of the hob to your personal needs. Several settings can be altered in succession.

After accessing programming mode, the + sensor and *PC* will appear in the timer display. After a few seconds *P:01* (Programme 01) will flash alternately with *C:01* (Code) in the timer display.

Changing the programming

Accessing programming mode

- **With the hob switched off**, touch and hold the ① and $\overline{\text{III}}$ sensors together until the + sensor lights up and *PC* appears in the timer display.

Setting the programme

For a two-digit programme number you need to first set the tens position.

- Whilst the programme is visible in the display (e.g. *P:01*), touch the + sensor repeatedly until the number for the programme you want appears in the display or touch the appropriate number on the numerical display.

Setting the code

- Whilst the code is visible in the display (e.g. *C:01*), touch the + sensor repeatedly until the number for the code you want appears in the display or touch the appropriate number on the numerical display.

Saving the settings

- Whilst the programme is visible in the display (e.g. *P:01*), touch the ① sensor until the indicators go out.

To avoid saving the settings

- While the code is showing in the display (e.g. *C:01*) touch the ① sensor until the indicators go out.

Programming

Programme ¹⁾		Code ²⁾	Settings
P:01	Demo mode	C:00	Demo mode off
		C:01	Demo mode on ³⁾
P:02	Power management ⁴⁾	C:00	Off
		C:01	3680 W
		C:02	3000 W
		C:03	2000 W
		C:04	1000 W
P:03	Factory default setting	C:00	Do not restore factory default settings
		C:01	Restore factory default settings
P:04	Number of cooking zone power levels	C:00	9 power levels + Booster
		C:01	17 power levels + Booster ⁵⁾
P:06	Audible tone when a sensor control is touched	C:00	Off ⁶⁾
		C:01	Quiet
		C:02	Medium
		C:03	Loud
P:07	Timer buzzer	C:00	Off ⁶⁾
		C:01	Quiet
		C:02	Medium
		C:03	Loud
		C:04	Maximum volume
P:08	System lock	C:00	System lock can only be activated manually
		C:01	System lock activated automatically

Programme ¹⁾		Code ²⁾	Settings
P:09	Maximum operating time	C:00	Safety setting 0
		C:01	Safety setting 1
		C:02	Safety setting 2
P:10	WiFi registration	C:00	Not active/deactivated
		C:01	Active but not configured
		C:02	Active and configured (cannot be selected; displays whether connection was successful)
		C:03	Connection possible via WPS push button
		C:04	WiFi reset to default (C:00)
		C:05	Direct WiFi connection of hob and external cooker hood without Miele app (Con@ctivity 3.0)
P:12	Sensor controls reaction speed	C:00	Slow
		C:01	Normal
		C:02	Fast
P:15	Permanent pan recognition	C:00	Not active
		C:01	Active
P:16	Con@ctivity of built-in vapour extraction	C:00	Con@ctivity off
		C:01	Con@ctivity on
P:17	Vapour extraction operating mode	C:00	Recirculation mode
		C:01	Extraction mode
P:18	Defining start for automatic operating mode of vapour extraction	C:00	Always start in manual mode
		C:01	Always start in automatic mode
		C:02	Start with the most recently set operating mode

Programming

Programme ¹⁾		Code ²⁾	Settings
P:19	Number of vapour extraction power levels	C:00	3 power levels + Booster
		C:01	9 power levels + Booster

- 1) Unlisted programmes are not assigned.
- 2) The factory-set code is shown in bold.
- 3) After the hob has been switched on dE appears in the timer display for a few seconds.
- 4) The total hob power may be reduced in order to meet the local power supply provider's requirements.
- 5) In the text and charts, the extended power levels are shown with a dot after the number for better understanding.
- 6) The audible tone for the On/Off sensor control cannot be switched off.

Note for test institutes

Test food acc. to EN 60350-2

9 power levels are programmed at the factory.

For testing in accordance with the above standard, programme the hob to the extended power level setting.

Test food	Ø Pan base (mm)	Lid	Power level	
			Pre-heat	Cooking
Heating oil up	150	No	–	1–2
Pancakes	180 (Sandwich base)	No	9	5.–7.
Frying deep frozen chips	According to the standard	No	9	9

Cleaning and care

 Risk of burning due to hot cooking zones.

The cooking zones will be hot after use.

Switch the hob off.

Allow the cooking zones to cool down before cleaning the hob.

 Risk of damage due to moisture ingress.

The steam from a steam cleaning appliance could reach live electrical components and cause a short circuit.

Do not use a steam cleaner to clean the hob.

All surfaces could be discoloured or damaged if unsuitable cleaning agents are used. All surfaces are susceptible to scratching.

Remove all cleaning agent residues immediately.

Never use abrasive sponges or cleaning agents.

- Clean the hob after every use.
- Dry the hob thoroughly after cleaning with water to avoid limescale residue.

Unsuitable cleaning agents

To avoid damaging the surfaces of the appliance, do not use:

- washing-up liquid
- cleaning agents containing soda, alkalines, ammonia, acids or chlorides
- cleaning agents containing descaling agents
- stain and rust removers
- abrasive cleaning agents, e.g. powder cleaners and cream cleaners
- solvent-based cleaning agents
- dishwasher cleaner
- oven sprays
- glass cleaning agents
- hard, abrasive brushes or sponges (e.g. pot scourers) or sponges which have been previously used and still contain abrasive cleaning agents
- melamine eraser blocks

Cleaning the ceramic surface

 Risk of damage by pointed objects.

The seal between the hob and the worktop could suffer damage.

The seal between the ceramic surface and the frame could suffer damage.

Do not use pointed objects for cleaning.

Not all soiling and residues can be removed using a solution of washing-up liquid. An invisible film can develop that can lead to discolouration of the glass ceramic surface. This discolouration cannot be removed.

Clean the ceramic surface regularly with a proprietary ceramic glass cleaning agent.

- Remove any coarse soiling with a damp cloth and more stubborn soiling with a shielded scraper blade suitable for use on glass.
- Then clean the ceramic glass surface with the Miele ceramic and stainless steel hob cleaner (see “optional accessories”) or with a proprietary ceramic glass cleaner applied with kitchen paper or a clean cloth. Do not apply the cleaner while the hob is still hot, as this can result in marking. Please follow the cleaning agent manufacturer's instructions.
- Finally wipe the glass ceramic surface with a damp cloth and polish with a soft, dry cloth.

Residues can burn onto the hob the next time it is used and cause damage to the glass ceramic surface. Ensure that all cleaning agent residues are removed.

- **Spots** caused by limescale, water and aluminium residues (spots with a metallic appearance) can be removed using Miele's ceramic and stainless steel hob cleaner.

 Risk of burning due to hot cooking zones.

The cooking zones are hot during use.

Wear oven gloves when removing residues of sugar, plastic or aluminium foil from a hot ceramic surface with a shielded scraper blade.

- Should any **sugar, plastic or aluminium foil** spill or fall onto the hot ceramic surface while it is in use, switch off the cooking zone.
- Then carefully scrape off these residues **immediately** whilst they are still hot, using a scraper blade suitable for use on glass.
- Afterwards, clean the ceramic surface in its cooled state, as described above.

Cleaning and care

Grease filter/extraction grille

The extraction grille and the reusable metal grease filter in the vapour extraction fan collect solid matter from kitchen vapours (grease, dust, etc.) and therefore prevent soiling of the downdraft extractor. Accumulated grease solidifies over a longer period of time and makes cleaning more difficult. The grease filter should therefore be cleaned at least every 3–4 weeks.

 Risk of fire due to soiled grease filter.
Grease collected in the grease filter can ignite.
Clean the grease filter regularly.

Removing the extraction grille

Risk of damage to the extraction grille.
Pull the extraction grille vertically out of the top of the KMDA.

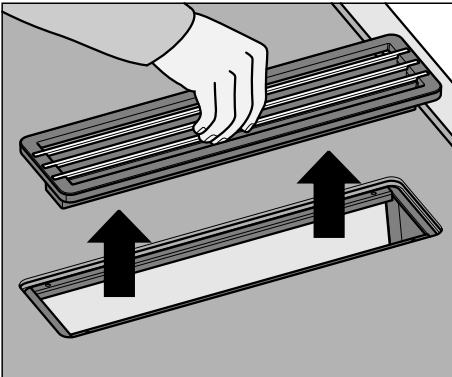

- Take hold of the extraction grille in the centre of the bars.
- Pull the extraction grille up vertically.

Removing the grease filter

- Lift up the extraction grille.
- Remove the grease filter carefully. Do not let the grease filter tip over.
- Pour out any liquid which has collected at the bottom of the grease filter.

Fitting the grease filter

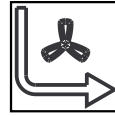

The grease filter has a symbol on the front. The arrow on this points to the right or left.

- Insert the grease filter so that the arrow is pointing to the opening inside the casing.

Cleaning the extraction grille and the grease filter by hand

- Clean the extraction grille and the grease filter with a soft nylon brush in a mild solution of hot water and a little washing-up liquid. Do not use concentrated washing-up liquid.

Cleaning the extraction grille and the grease filter in the dishwasher

- Place the extraction grille upright in the lower basket.
- Place the grease filter with its base facing upwards in the lower basket. Ensure the spray arm is not obstructed.
- Use a standard household dishwasher detergent.
- Select a dishwasher programme with a maximum wash temperature of:
 - 55 °C for the extraction grille
 - 65 °C for the grease filter

Depending on the detergent used, cleaning the grease filter in a dishwasher can cause permanent discolouration to the internal surfaces of the filter. However, this will not affect the functioning of the grease filter in any way.

Cooker hood drip tray

Clean the drip tray if liquid from food being spilled or boiling over has got into the cooker hood.

- Remove and clean the grease filter as described in “Cleaning and care” –“Grease filter/Extraction grille”.

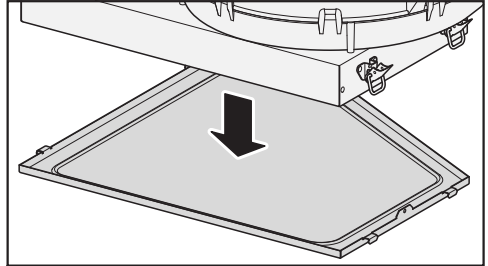

- Hold the drip tray securely and open the 4 catches (2 on the right and 2 on the left). Carefully remove the tray from the casing, making sure it is kept horizontal.
- Pour out the liquid.
- Clean and dry the drip tray.
- Also clean and dry accessible areas inside of the cooker hood.
- Fasten the drip tray back onto the casing.
- Replace the grease filter and replace the extraction grille.

Internal surfaces of the cooker hood

- Whilst the grease filter is removed remove any grease deposits from all accessible areas of the housing. Doing so will prevent a fire hazard.

Cleaning and care

Resetting the grease filter operating hours counter

After cleaning the grease filter, the operating hours counter needs to be reset.

- Touch the  sensor for 3 seconds.

The sensor will go out.

Reactivating charcoal filter

The charcoal filter needs to be reactivated after 120 operating hours. The  sensor will light up.

- Reactivate the charcoal filter as described in the operating instructions supplied with the recirculation box.

Resetting the charcoal filter operating hours counter

- Touch the  sensor for 3 seconds.

The sensor will go out.

Problem solving guide

Many malfunctions and faults that can occur in daily operation can be easily remedied. Time and money will be saved because a service call will not be needed.

The following guide may help you to find the reason for a malfunction or a fault, and to correct it.

Problem	Cause and remedy
<p>The hob or cooking zones will not switch on.</p>	<p>There is no power to the hob.</p> <ul style="list-style-type: none"> ■ Check whether the mains fuse has tripped. Contact an electrician or Miele Service (for the minimum fuse rating, see data plate). <p>There may be a technical fault.</p> <ul style="list-style-type: none"> ■ Disconnect the appliance from the mains electricity supply for approx. 1 minute by <ul style="list-style-type: none"> – tripping the relevant mains fuse or screwing the fuse out completely, or – switching off at the residual current device. ■ If, after resetting the trip switch in the mains fuse box or the residual current device, the appliance will still not turn on, contact a qualified electrician or Miele Service.
<p>A smell and vapours are given off when the new appliance is being used.</p>	<p>The metal components have a protective coating. When the appliance is used for the first time, this causes a smell and possibly also vapour. The material from which the induction coils are made also gives off a smell in the first few hours of operation. With each subsequent use, the odour is reduced until it disappears completely. The smell and any vapours given off do not indicate a faulty connection or appliance and they are not hazardous to health.</p>
<p>In the cooking zone display, the \mathcal{L} symbol will flash alternately with the selected power level or \mathcal{R}.</p>	<p>An unsuitable pan has been placed on the hob.</p> <ul style="list-style-type: none"> ■ Use suitable pans (see “Pans” in the “Induction” chapter).



Problem solving guide

Problem	Cause and remedy
<p>After the hob has been switched on, or after touching a sensor, <i>LDC</i> appears in the timer display for a few seconds.</p>	<p>The system lock or safety lock is activated.</p> <ul style="list-style-type: none"> ■ Deactivate the system lock or safety lock (see “System lock / Safety lock”).
<p>The hob has switched off automatically. When the element is switched back on, <i>L</i> appears above the On/Off sensor control ①.</p>	<p>One or more of the sensor controls are covered, e.g. by finger contact, food boiling over or an object.</p> <ul style="list-style-type: none"> ■ Clean off any dirt and/or remove the object (see “Safety features” – “Safety switch-off”).
<p>After the hob has been switched on, <i>dE</i> appears briefly in the timer display. The cooking zones do not heat up.</p>	<p>The hob is in demonstration mode.</p> <ul style="list-style-type: none"> ■ Touch the 0 sensor control on any of the numerical displays. ■ Then touch the <i>U</i> and <i>Z</i> sensor controls at the same time until <i>dE</i> flashes alternately with <i>OFF</i> in the timer display.
<p>A cooking zone switches off automatically.</p>	<p>It has been operated for too long.</p> <ul style="list-style-type: none"> ■ You can use the cooking zone again by switching it back on (see “Safety switch-off”).
<p>A cooking zone or the whole hob switches off automatically.</p>	<p>The overheating protection mechanism has been activated.</p> <ul style="list-style-type: none"> ■ See “Safety features”.
<p>The Booster has deactivated early automatically.</p>	<p>The overheating protection mechanism has been activated.</p> <ul style="list-style-type: none"> ■ See “Safety features”.
<p>The cooking zone is not working in the usual way on the power setting selected.</p>	<p>The overheating protection mechanism has been activated.</p> <ul style="list-style-type: none"> ■ See “Safety features”.
<p>Power level 9 is automatically reduced if you select power level 9 on two linked cooking zones at the same time.</p>	<p>Operating both zones at power level 9 would exceed the permitted maximum power for the two zones.</p> <ul style="list-style-type: none"> ■ Use a different cooking zone.

Problem solving guide

Problem	Cause and remedy
<p>The food in the pan does not heat up when the Auto heat-up function is switched on.</p>	<p>A large amount of food is being heated up.</p> <ul style="list-style-type: none"> ■ Start cooking at the highest power level and then turn down to a lower one manually later on.
	<p>The pan is not conducting heat properly.</p> <ul style="list-style-type: none"> ■ Use a different pot or pan which conducts heat properly.
<p>An operating noise can be heard after the appliance has been switched off.</p>	<p>The cooling fan runs until the hob has cooled down and then switches off automatically.</p>
<p><i>Err</i> is flashing alternately with 30 in the timer display and the buzzer is sounding.</p>	<p>The hob is incorrectly connected.</p> <ul style="list-style-type: none"> ■ Disconnect the hob from the mains electricity supply. ■ Contact the Customer Service Department. The hob must be connected to the mains according to the wiring diagram.
<p>“E” and a number, e.g. E-0, is flashing alternately with a 3-digit number in the timer display.</p>	<p>Numbers 120–125 The fan is blocked or defective.</p> <ul style="list-style-type: none"> ■ Make sure it has not been blocked by an object. ■ Remove the obstruction. ■ If this fault code continues to appear in the display, contact the Customer Service Department.
	<p>Other numbers Fault in a zone</p> <ul style="list-style-type: none"> ■ Disconnect the power supply to the hob for approx. 1 minute. ■ If the problem persists after power has been restored, please contact the Customer Service Department.
<p>Liquid has got into the cooker hood.</p>	<p>Due to boiling over or spillage, liquid has made its way through the extraction grille into the cooker hood.</p> <p>The base of the grease filter can hold approx. 250 ml of liquid. The drip tray underneath the housing can hold a further 250 ml of liquid.</p> <ul style="list-style-type: none"> ■ Switch the cooker hood off. ■ Clean the grease filter, the drip tray and the inside of the housing (see “Cleaning and care”).

Problem solving guide

Problem	Cause and remedy
Extraction performance has decreased. Extraction noise has increased.	<p>Objects (e.g. a cloth) have been drawn into the cooker hood.</p> <ul style="list-style-type: none">■ Switch the cooker hood off.■ Remove the grease filter (see “Cleaning and care”).■ Remove any objects from the grease filter.
The  sensor control is lit up.	<p>The charcoal filter needs to be reactivated.</p> <ul style="list-style-type: none">■ If the cooker hood is being operated in Recirculation mode, reactivate the charcoal filter as described in the operating and installation instructions supplied with the recirculation box. Reset the operating hours counter (see “Cleaning and care” – “Resetting the charcoal filter operating hours counter” in these operating and installation instructions).■ If the cooker hood is being operated in Extraction mode, reset the operating hours counter (see “Cleaning and care” – “Resetting the grease filter operating hours counter” in these operating and installation instructions).
The  sensor control is lit up.	<p>The grease filter must be cleaned.</p> <ul style="list-style-type: none">■ Clean the grease filter as described in “Cleaning and care” – “Grease filter/Extraction grille”.

Miele offer a comprehensive range of useful accessories as well as cleaning and conditioning products for your Miele appliances.

These products can be ordered through the Miele Webshop.

They can also be ordered from Miele (see end of this booklet for contact details) or from your Miele dealer.

Cookware

Miele offers a wide range of cookware. These have all been optimised for Miele appliances in terms of functionality and dimensions. Detailed information is provided on the Miele website.

Cleaning and care products

Ceramic and stainless steel hob cleaner 250 ml



Removes heavy soiling, limescale deposits and aluminium residues

Microfibre cloth

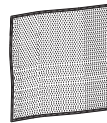



Removes finger marks and light soiling

Installation

Safety instructions for installation

 Damage risk from incorrect installation.
Incorrect installation can cause damage to the hob.
The hob must only be installed by a qualified person.

 Risk of electric shock.
Incorrect connection to the mains supply may result in an electric shock.
The hob must be connected to the electrical supply by a qualified person only.

 Damage from falling objects.
Take care not to damage the hob when fitting wall units or a cooker hood above it.
Fit the wall units and the cooker hood before the hob.

- ▶ The veneer or laminate coatings of worktops (or adjacent kitchen units) must be treated with 100 °C heat-resistant adhesive which will not dissolve or distort. Any backmoulds must be of heat-resistant material.
- ▶ The hob must not be installed over a fridge, fridge-freezer, freezer, dishwasher, washing machine, washer-dryer or tumble dryer.
- ▶ A gas hob must not be installed next to this hob.
- ▶ This hob must not be installed above ovens or cookers unless these have a built-in cooling down fan.
- ▶ After installation, ensure that nothing can come into contact with the connection cable and that it is without hindrance.
- ▶ The electrical cable may not come into contact with any moving kitchen component (e.g. a drawer) or be subject to mechanical obstruction which could damage it.
- ▶ Observe carefully the safety clearances listed on the following pages.

- ▶ Exhaust ducting must be of non-inflammable material. Suitable material is available from Miele specialist dealers or the Miele Spares Dept.
- ▶ The appliance must not be connected to a chimney or flue which is in use. Neither should it be connected to ducting which ventilates rooms with fireplaces.
- ▶ If exhaust air is to be extracted into a chimney or ventilation duct no longer used for other purposes, seek professional advice.
- ▶ The extracted air drawn into the cooker hood must not be routed into the base unit, as this will damage the cabinet. The extracted air must be routed outside through ducting (extraction mode) or back into the room through the recirculation box (recirculation mode).

Installation

Safety distances

Safety distance above the hob

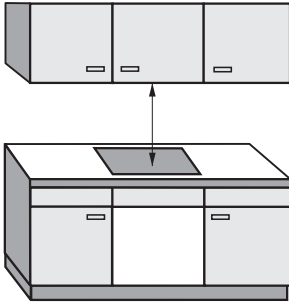

The safety distance specified by the manufacturer of the cooker hood must be maintained between the hob and the cooker hood above it.

If combustible objects are installed above the hob (e.g., cabinets, utensil rail, etc.), a minimum safety distance of 600 mm must be maintained.

When two or more appliances which have different safety distances are installed together below a cooker hood, you should observe the greatest specified safety distance.

Safety distances to the sides and back of the hob

It is advisable to install the hob with plenty of space either side of it.

The minimum distance ① shown below must be maintained between the back of the hob and a tall unit or wall.

The minimum distance ②, ③ shown below must be maintained between a tall unit or a wall to the left or right of the hob with a minimum distance of 300 mm on the opposite side.

① Minimum distance between the **back** of the worktop cut-out and the rear edge of the worktop:
50 mm

② Minimum distance between the worktop cut-out and a wall or tall unit to the **right** of it:
50 mm.

③ Minimum distance between the worktop cut-out and a wall or tall unit to the **left** of it:
50 mm.

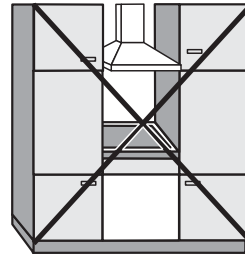

Not allowed

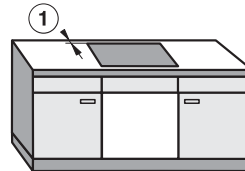
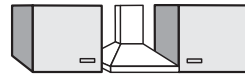

Highly recommended

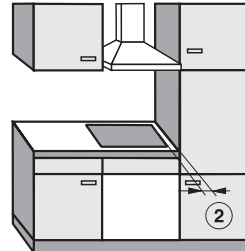

Not recommended

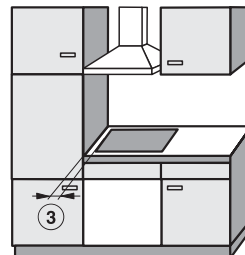

Not recommended

Installation

Safety distance when installing the appliance near a wall with additional niche cladding

A minimum safety distance must be maintained between the worktop cut-out and any niche cladding to protect it from heat damage.

If the niche cladding is made from a combustible material (e.g. wood) a minimum safety distance ⑤ of 50 mm must be maintained between the cut-out and the cladding.

If the niche cladding is made from a non-combustible material (e.g. metal, natural stone, ceramic tiles) the minimum safety distance ⑤ between the cut-out and the cladding will be 50 mm less the thickness of the cladding.

Example: 15 mm niche cladding

50 mm - 15 mm = minimum safety distance of 35 mm

Flush-fitted hobs

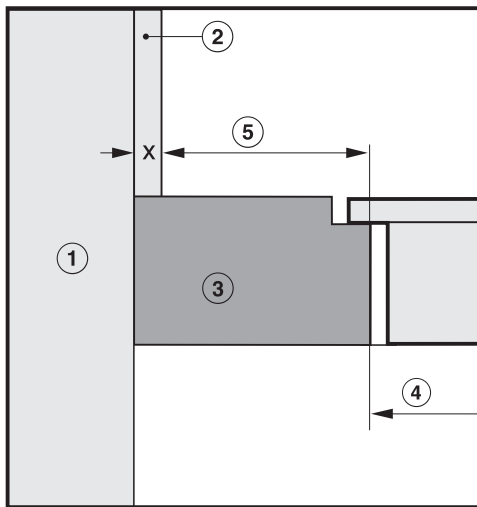

Hob with frame or bevelled edge

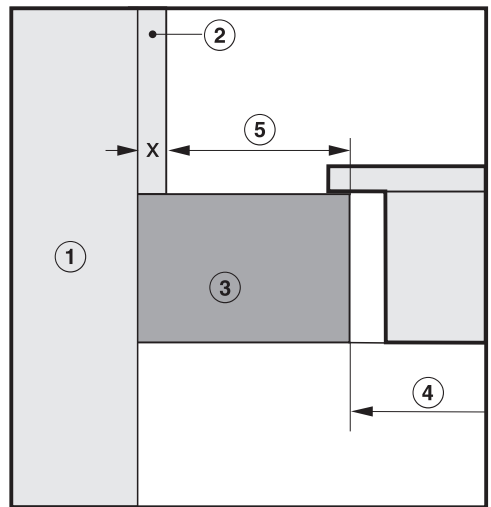

- ① Masonry
- ② Niche cladding dimension x = thickness of the niche cladding material
- ③ Worktop
- ④ Worktop cut-out
- ⑤ Minimum distance to
 - combustible** materials 50 mm
 - non-combustible** materials 50 mm - dimension x

Installation notes

All dimensions are given in mm.

Surface-mounted installation

Seal between the hob and the worktop

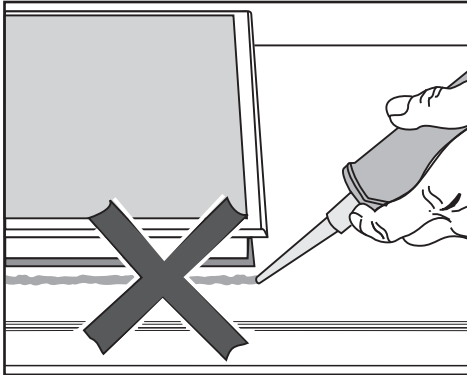

 Damage caused by incorrect installation.

Using sealant under the hob could result in damage to the hob and the worktop if the hob ever needs to be removed for servicing.

Do not use sealant between the hob and the worktop.

The sealing strip under the edge of the hob provides a sufficient seal for the worktop.

Tiled worktops

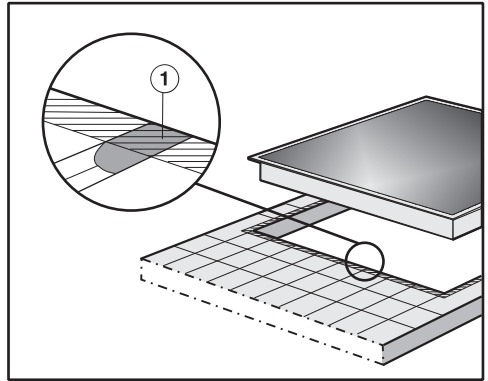

Grout lines ① and the hatched area underneath the hob frame must be smooth and even. If they are not the hob will not sit flush with the worktop and the sealing strip underneath the hob will not provide a good seal between the hob and the worktop.

Installation

Flush-fit installation

Flush-fit installation is only possible in natural stone (granite, marble), solid wood and tiled worktops. Certain models are suitable for building into glass worktops – please see the relevant label on the hob. When using a worktop made from any other material, please check first with the worktop manufacturer that it is suitable for installing a flush-fit hob.

The internal width of the base unit underneath the appliance must be at least as wide as the inner worktop cut-out (see “Installation – Building-in dimensions – flush fit”), so that the hob is easily accessible from underneath after installation and the bottom half of the casing can be removed for maintenance. If the underside of the hob is not freely accessible after installation, any sealant used to plug the gaps around the appliance must be removed to enable the hob to be lifted out of the cut-out should this be necessary.

Natural stone worktops

The hob is set directly in the cut-out.

Solid wood worktops, tiled worktops, glass worktops

The hob is secured inside the cut-out with wooden battens. The battens must be provided on site, and are not supplied with the appliance.

Minimum plinth height

The minimum plinth height is 100 mm.

Housing unit back panel

The extraction ducting is laid behind the housing unit back panel. The back panel must be removable for maintenance purposes.

Drip tray

The hob must be installed such that the drip tray is easily accessible as it needs to be removed for cleaning.

Sealing strip

Dismantling the hob for service purposes may damage the sealing strip underneath the edge of the hob.

Always replace the sealing strip before reinstalling the hob.

Installation examples

Recirculation mode

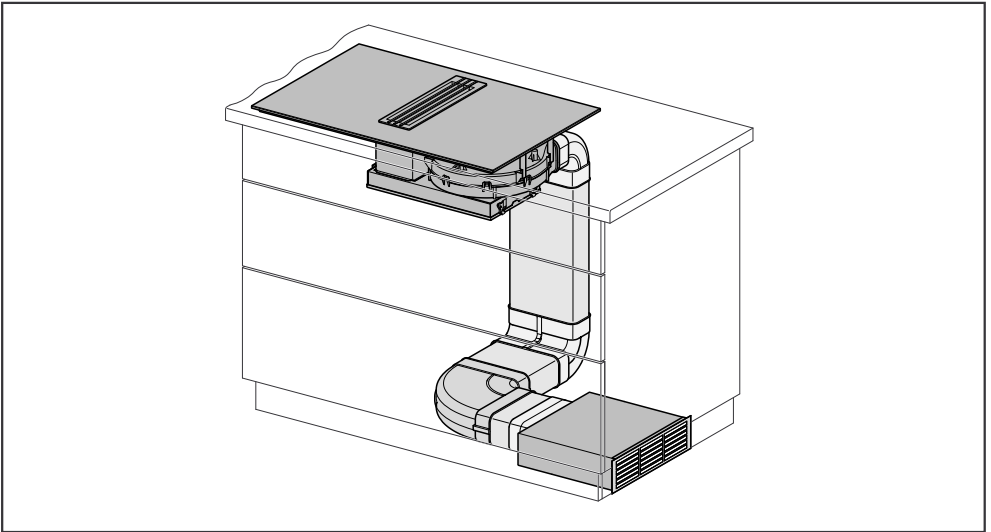

Extraction mode

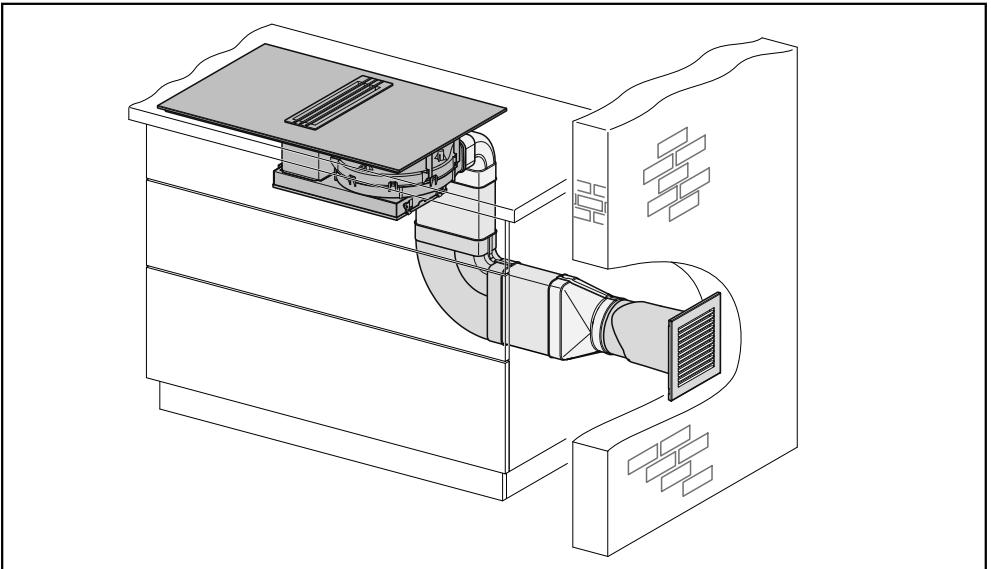

Installation

Installation dimensions – Surface-mounted

KMDA 7476 FR

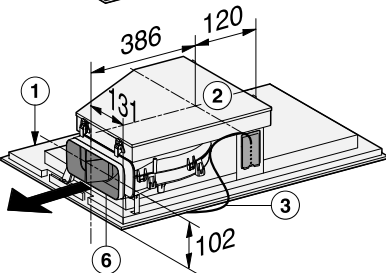
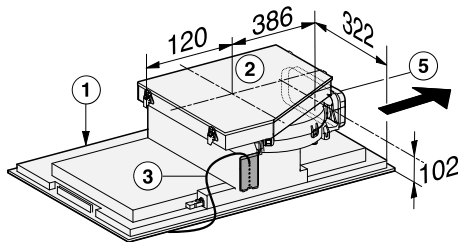
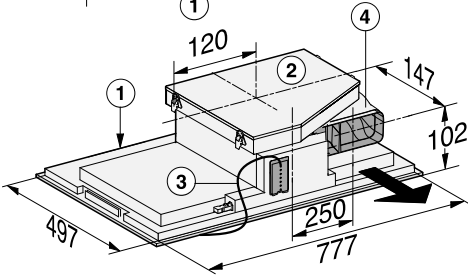
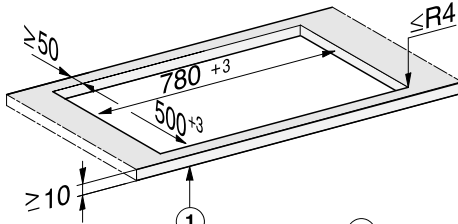
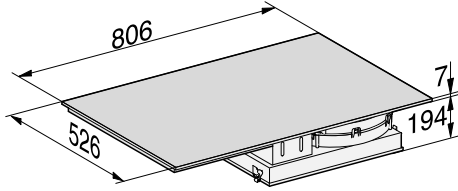

- ① Front
- ② Removable drip tray
- ③ Mains connection box with mains connection cable, L = 1440 mm
- ④ Air duct connection – at the back (ex-works)
- ⑤ Air duct connection – on the right (conversion required)
- ⑥ Air duct connection – on the left (conversion required)

KMDA 7476 FL

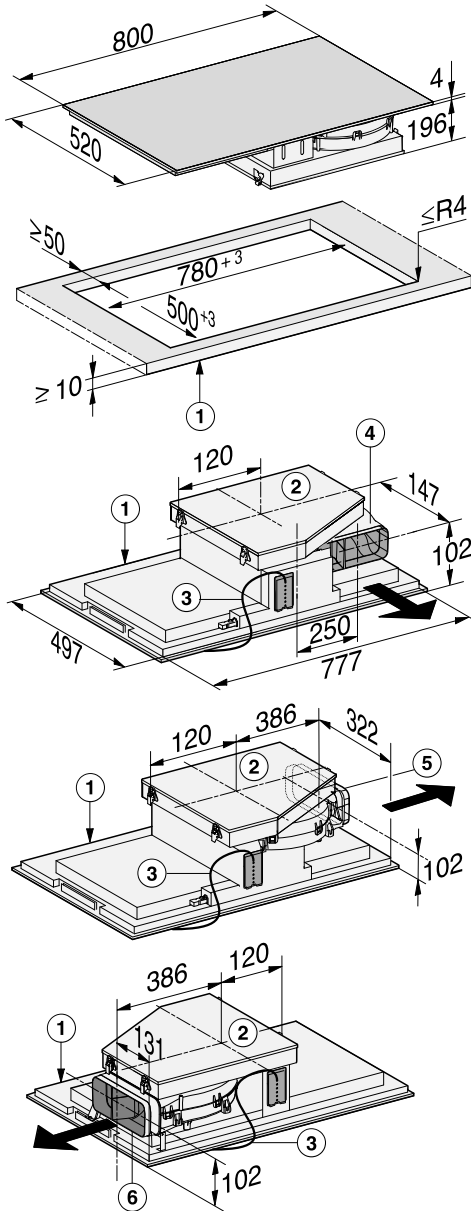

- ① Front
- ② Removable drip tray
- ③ Mains connection box with mains connection cable, L = 1440 mm
- ④ Air duct connection – at the back (ex-works)
- ⑤ Air duct connection – on the right (conversion required)
- ⑥ Air duct connection – on the left (conversion required)

Installation

Worktop depth 600 mm

KMDA 7476 FL

KMDA 7476 FR

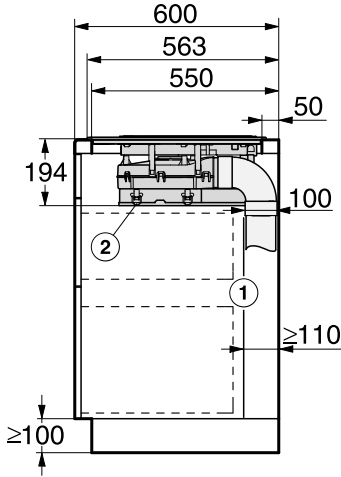

- ① Housing unit back panel
The housing unit back panel must be removable for service work. The housing unit wall and an adjoining room wall or a piece of furniture must be at least 110 mm apart to ensure sufficient room for the ducting.
- ② Drip tray
After installation the removable drip tray must be accessible from below.

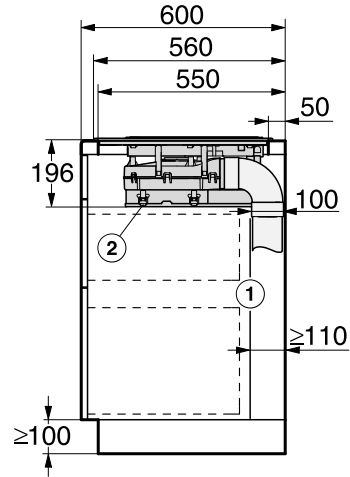

- ① Housing unit back panel
The housing unit back panel must be removable for service work. The housing unit wall and an adjoining room wall or a piece of furniture must be at least 110 mm apart to ensure sufficient room for the ducting.
- ② Drip tray
After installation the removable drip tray must be accessible from below.

Extraction to the rear (standard)

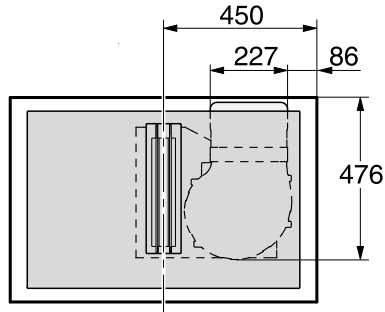

Extraction to the right

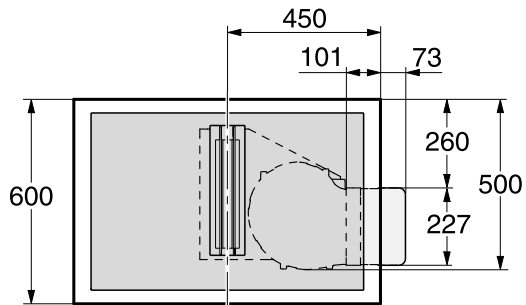

Extraction to the left

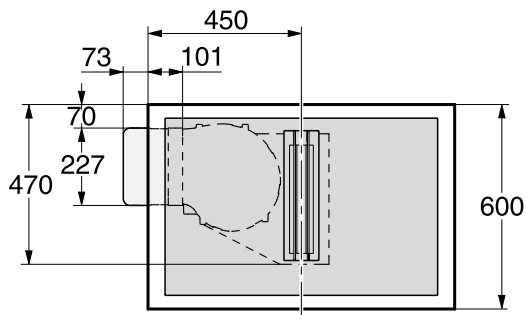

Installation

Worktop depth greater than 600 mm

KMDA 7476 FL

KMDA 7476 FR

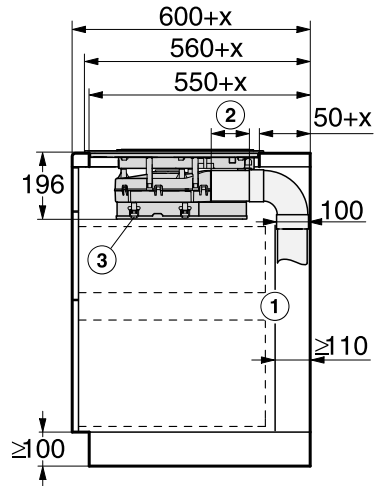
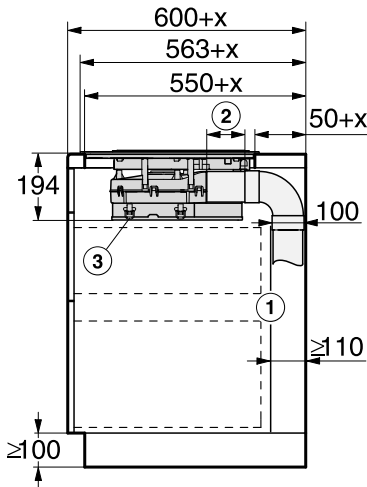

- ① Housing unit back panel
The housing unit back panel must be removable for service work. The housing unit wall and an adjoining room wall or a piece of furniture must be at least 110 mm apart to ensure sufficient room for the ducting.
 - ② Variable length of interim piece
 - ③ Drip tray
After installation the removable drip tray must be accessible from below.
- x = Dimension by which the worktop is deeper than 600 mm.

- ① Housing unit back panel
The housing unit back panel must be removable for service work. The housing unit wall and an adjoining room wall or a piece of furniture must be at least 110 mm apart to ensure sufficient room for the ducting.
 - ② Variable length of interim piece
 - ③ Drip tray
After installation the removable drip tray must be accessible from below.
- x = Dimension by which the worktop is deeper than 600 mm.

Extraction to the rear (standard)

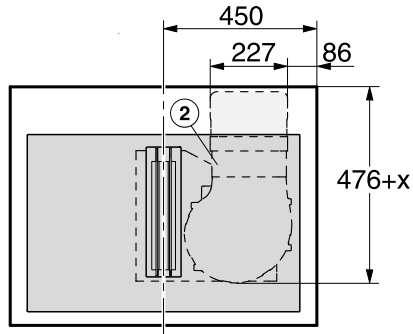

Extraction to the right

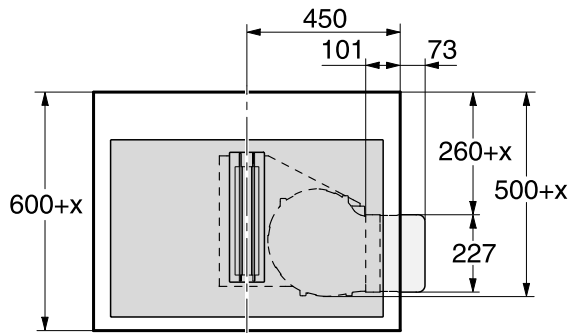

Extraction to the left

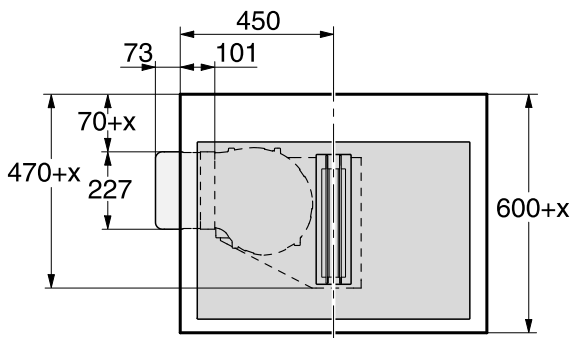

Installation

Installation dimensions – Flush-mounted

KMDA 7476 FL

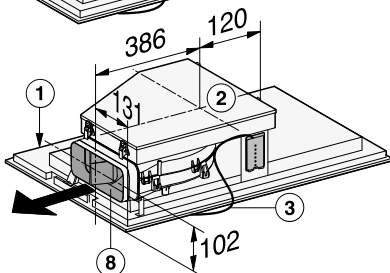
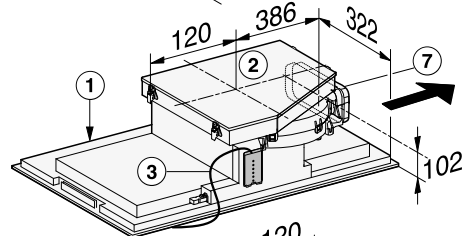
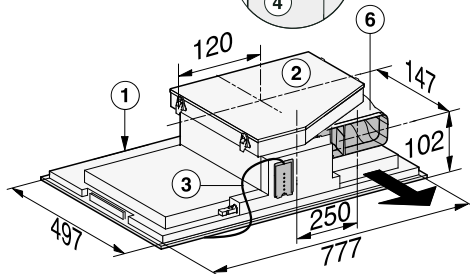
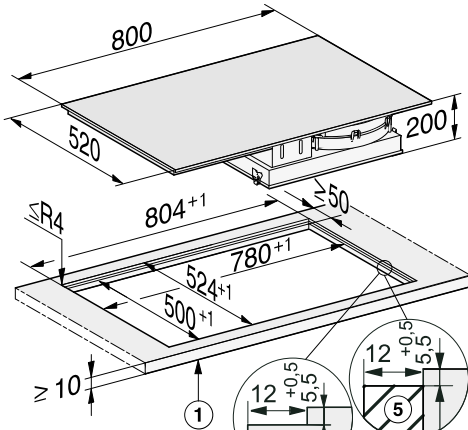

- ① Front
- ② Removable drip tray
- ③ Mains connection box with mains connection cable, L = 1440 mm
- ④ Stepped cut-out
- ⑤ Wooden frame (to be provided on site)
- ⑥ Air duct connection – at the back (ex-works)
- ⑦ Air duct connection – on the right (conversion required)
- ⑧ Air duct connection – on the left (conversion required)

Worktop depth 600 mm

KMDA 7476 FL

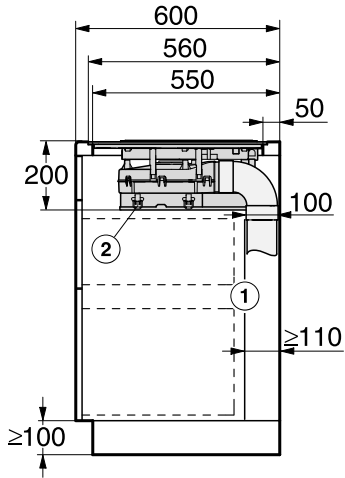

- ① Housing unit back panel
The housing unit back panel must be removable for service work. The housing unit wall and an adjoining room wall or a piece of furniture must be at least 110 mm apart to ensure sufficient room for the ducting.
- ② Drip tray
After installation the removable drip tray must be accessible from below.

Installation

Extraction to the rear (standard)

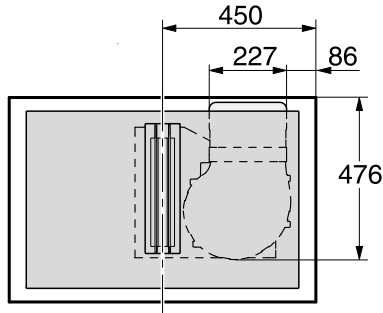

Extraction to the right

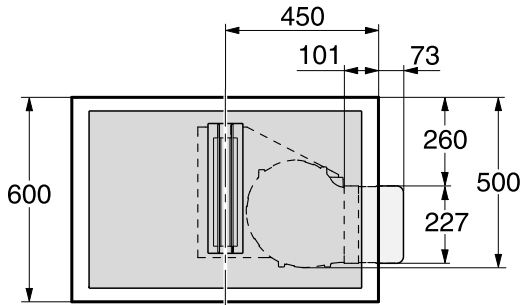

Extraction to the left

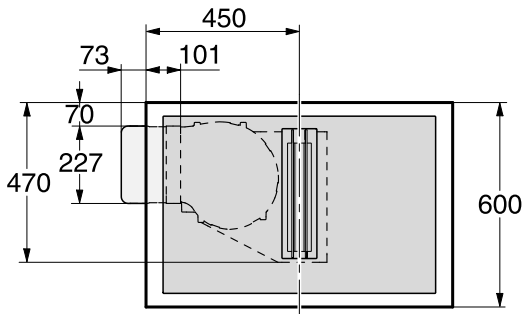

Worktop depth greater than 600 mm

KMDA 7476 FL

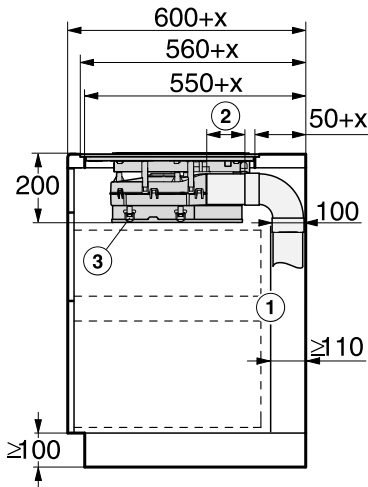

- ① Housing unit back panel
The housing unit back panel must be removable for service work. The housing unit wall and an adjoining room wall or a piece of furniture must be at least 110 mm apart to ensure sufficient room for the ducting.
 - ② Variable length of interim piece
 - ③ Drip tray
After installation the removable drip tray must be accessible from below.
- x = Dimension by which the worktop is deeper than 600 mm.

Installation

Extraction to the rear (standard)

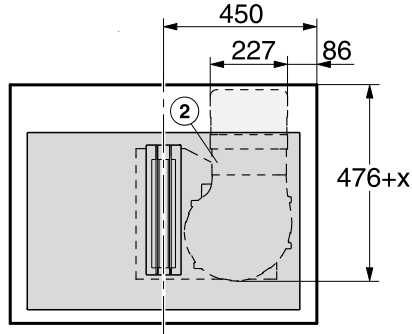

Extraction to the right

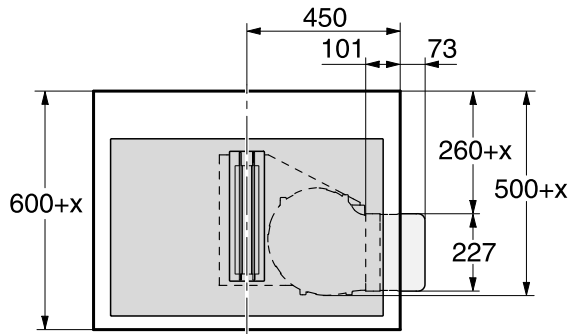

Extraction to the left

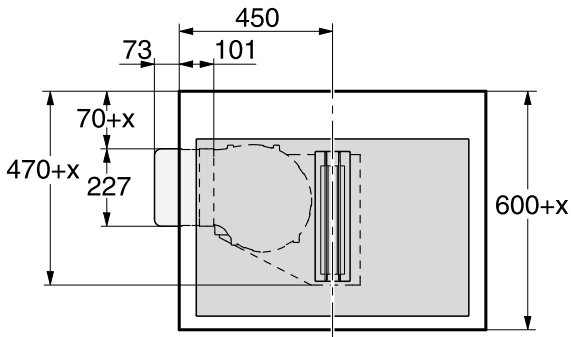

Extraction direction modification

If you modify the extraction direction, the original brackets will no longer be required.

- Use the bracket provided separately with the cooker hood once the extraction direction has been modified.

Keep the original brackets in case the extraction direction needs to be modified again.

Turning the extraction ducting connection clockwise

- Place the hob on its ceramic surface on a soft underlay.

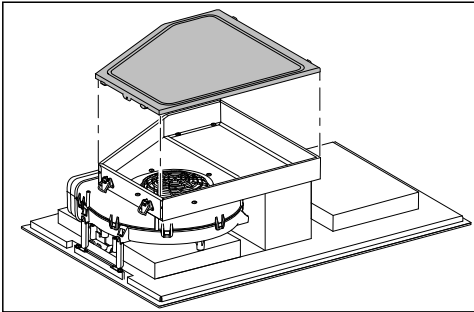

- Release the 4 catches and remove the drip tray.

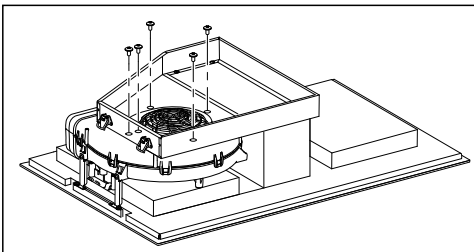

- Undo the 5 screws on the fan.

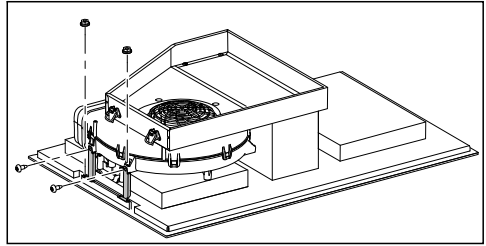

- Undo the fixing bracket.

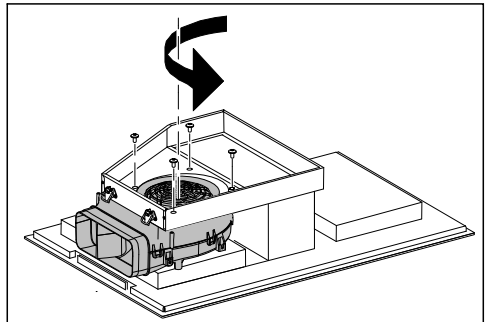

- Rotate the fan by 90°.
- Secure the fan again (you only need 4 screws). Make sure that the plastic edge is on the left.

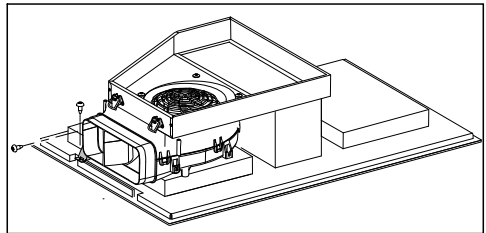

- Use the bracket supplied separately to secure the fan.
- Place the cooker hood onto the drip tray again and secure the tray using the 4 catches.

Installation

Turning the extraction ducting connection anticlockwise

- Place the hob on its ceramic surface on a soft underlay.

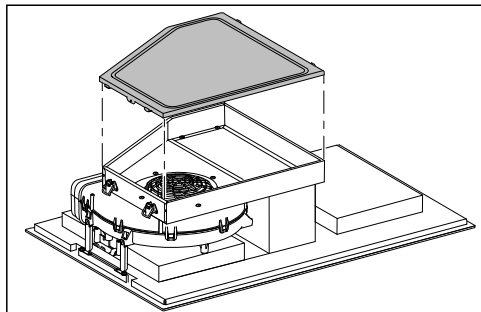

- Release the 4 catches and remove the drip tray.

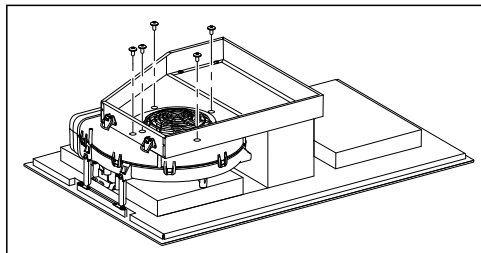

- Undo the 5 screws on the fan.

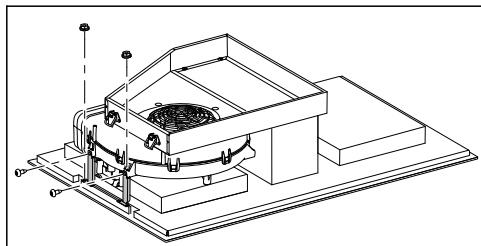

- Undo the fixing bracket.

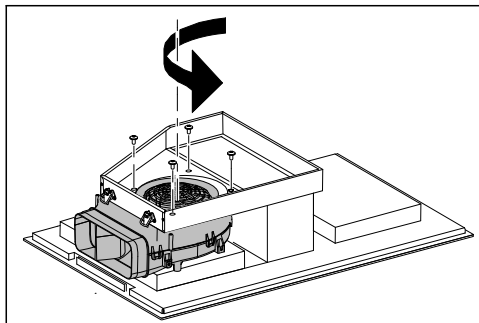

- Rotate the fan by 90°.
- Secure the fan again (you only need 4 screws). Make sure that the plastic edge is on the left.

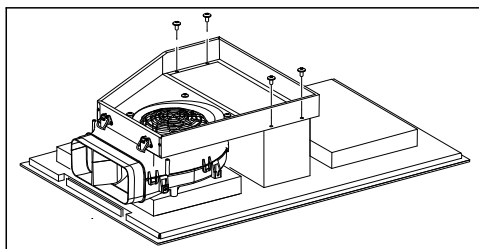

- Undo the 4 screws on the frame.

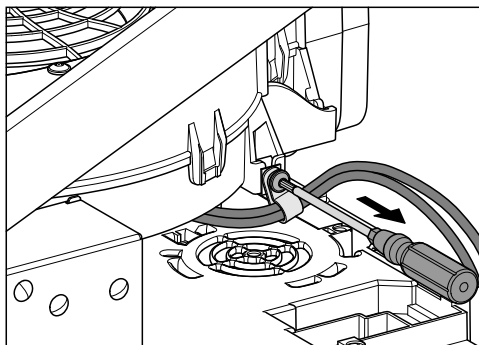

- Loosen the cable tie.

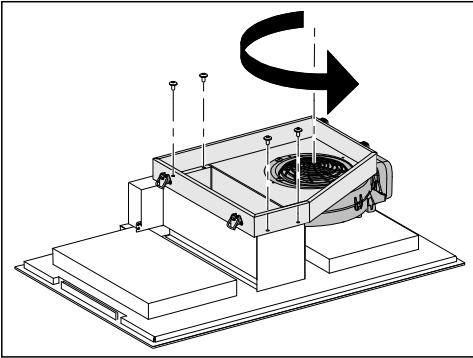

- Lift the frame and the fan and turn it 180°.

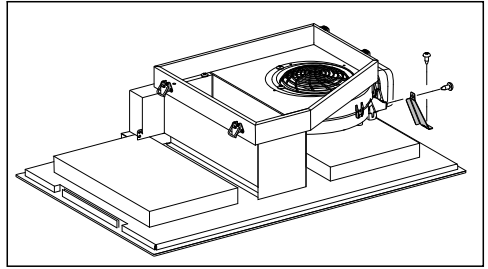

- Use the bracket supplied separately to secure the fan.
- Place the cooker hood onto the drip tray again and secure the tray using the 4 catches.

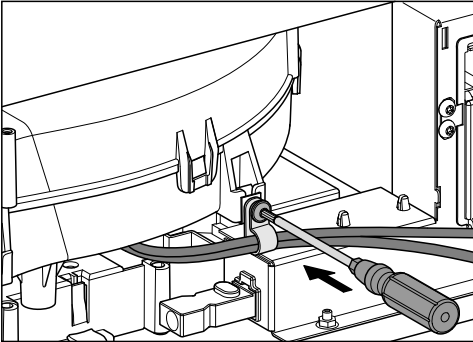

- Guide the cable under the fan.
- Reattach the cable tie.
- Refit the 4 screws in the frame.

Installation

Connection to window contact, if required

⚠ The window contact connection is live!

Danger of electric shock!

Disconnect the hob from the mains electricity supply before connecting the switching mechanism.

The connection cable for the switching system must only be connected by a suitably qualified and competent electrician.

The connection cable for the switching system must comply with type H03VV-F 2 x 0.75 mm² and must not exceed 2.0 m in length.

The switching system must be equipped with a potential-free contact suitable for 230 V, 1 A. The extractor is switched off when the switch is open.

Only use DIPT-approved and tested radio switching systems (e.g. window contact switches, pressure switches) and have them approved by authorised specialists (e.g. building regulations inspector).

The switching system must be suitable for use with a BLDC motor.

You will need the appropriate external switching system documents to safely connect and operate the switch.

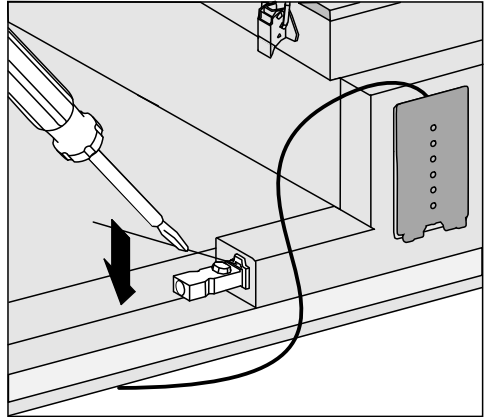

- Loosen the lug and pull the plug out.

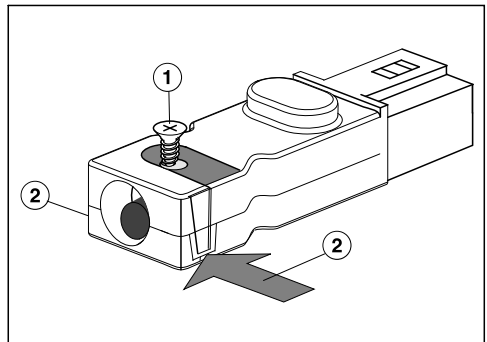

- Loosen the strain relief screw ① and unlock the casing on both sides ②.
- Open the casing.
- Remove the stopper.

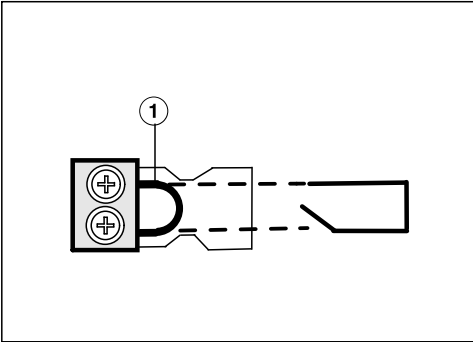

- Exchange the bridge ① for the connection cable of the switching system.
- Close the casing.
- Tighten the strain relief screw.
- Reinsert the plug.

Installation

Surface-mounted installation

- Create the worktop cut-out. Remember to maintain the minimum safety distances (see “Installation – Safety distances”).
- Seal any cut surfaces on **wooden worktops** with a special varnish, silicone sealant or resin to prevent the wood from swelling as a result of moisture ingress. The sealant must be heat-resistant.

Make sure that the sealant does not come into contact with the top of the worktop.

- Attach the seal provided underneath the edge of the hob.
- Feed the mains connection cable for the hob down through the worktop cut-out.
- Place the hob centrally in the cut-out. When doing this, make sure that the seal of the appliance sits flush with the worktop on all sides. This is important to ensure an effective seal all round.

Do not use any additional sealant (e.g. silicone) on the hob.

If the seal does not sit flush with the worktop in the corners, the corner radius ($\leq R4$) can be carefully cut to fit using a jigsaw.

- Connect the hob to the mains.
- Check that the hob works.

Flush-fit installation

- Create the worktop cut-out. Remember to maintain the minimum safety distances (see “Safety distances”).
- Solid wood, tiled and glass worktops:
Fix a wooden frame 5,5 mm below the top edge of the worktop (see building-in diagram for “Flush-fit installation”).
- Stick the supplied sealing strip under the edge of the hob.
- Feed the mains connection cable for the hob down through the worktop cut-out.
- Centre the hob in the cut-out.

The gap between the ceramic surface and the worktop must be at least 2 mm wide. This is required so that the hob can be sealed.

- Connect the hob to the mains.
- Check that the hob works.
- Seal the gap between the hob and worktop with a silicone sealant that is heat-resistant to at least 160 °C.



Damage from unsuitable sealant.

Unsuitable sealant can damage natural stone.

For natural stone worktops and natural stone tiles, only use silicone sealant that is specially formulated for natural stone. Follow the manufacturer's instructions.

Installation

Ducting

⚠ If the cooker hood is used at the same time as a heating appliance that relies on oxygen from the same room, there is a risk of toxic fumes. It is essential that the “Warning and safety instructions” are observed.

The cooker hood should be installed according to local and national building regulations. Seek approval from the building inspector where necessary.

The cooker hood has an exhaust connection of 222 x 89 mm.

- For ducting, use smooth pipes or flexible ducting made from approved non-flammable materials.
- To achieve the most efficient air flow rate with the lowest noise levels, please note the following:
 - The cross-section of the ducting must not be smaller than the cross-section of the exhaust connection (see “Appliance dimensions”).
 - The ducting should be as short and straight as possible.
 - Only use wide radius bends.
 - The ducting must not be kinked or compressed.
 - Ensure that all connections are strong and airtight.

Remember that any constriction of the air flow rate will reduce extraction performance and increase operating noise.

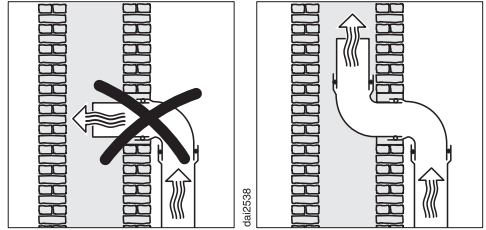

- If the exhaust air is to be ducted into a flue, the ducting must be directed in the flow direction of the flue.
- If ducting is to be laid horizontally it must be laid with a downwards sloping gradient. This is to ensure that condensate cannot drain back into the extractor.
- If the ducting is to run through rooms, ceiling space, etc. there may be great variations in temperature between the different areas. The problem of condensation will need to be addressed. The ducting will need to be suitably insulated.

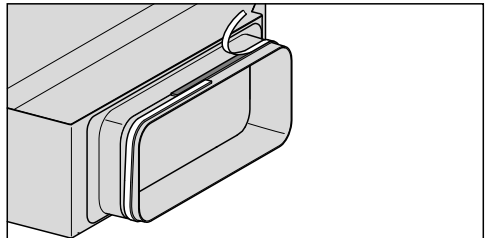

- If the vent ducting does not sit securely up against the vent connection, stick the sealing strip supplied to it.

Electrical connection

 Risk of damage from incorrect connection.

Unauthorised installation, maintenance and repairs can cause considerable danger for the user.

Miele cannot be held liable for damage or injury caused by unauthorised installation, maintenance or repair work, or by an inadequate or faulty on-site earthing system (e.g. electric shock).

This hob must be connected to the electrical supply by a qualified electrician.

The electrician must be familiar with and comply with the national regulations and any additional regulations of the local electricity provider (e.g. BS 7671 in the UK).

After installation, ensure that all electrical components are shielded and cannot be accessed by users.

Total power rating

See data plate

Connection data

The connection data is quoted on the data plate. Please ensure these match the household mains supply.

Please see wiring diagrams for connection. (N.B. This appliance is supplied single phase only in the UK / AUS / NZ).

Residual current device

For extra safety, it is advisable to protect the appliance with a suitable residual current device (RCD) with a trip range of 30 mA.

WARNING
THIS APPLIANCE MUST BE EARTHED

Disconnecting devices

It must be possible to disconnect the hob from the mains at all poles using disconnecting devices. A contact distance of at least 3 mm must be observed in the switched-off state. The disconnecting devices are overcurrent protection devices and residual current protection devices.

Installation

Disconnecting from the mains

 Risk of electric shock.

There is a risk of electric shock if the appliance is connected to the mains supply during repair or service work. After disconnection, ensure the appliance cannot be switched back on by mistake.

To disconnect the appliance from the mains power supply, do one of the following depending on installation:

Safety fuses

- Completely remove fuses.

Automatic circuit breakers

- Press the (red) test button until the middle (black) button springs out.

Built-in circuit breakers

- Circuit breakers at least type B or C:
Switch the lever from 1 (on) to 0 (off).

Residual current device (RCD)

- Switch the main switch from 1 (on) to 0 (off) or press the test button.

Mains connection cable

The hob must be connected to the electrical supply with a special connection cable, type H 05 VV-F (PVC insulated) with a suitable diameter.

Please see wiring diagram for connection. (N.B. This appliance is supplied single phase only in the UK / AUS / NZ).

See the data plate on the hob for the correct voltage and frequency.

Replacing the mains connection cable

 Risk of electric shock.

Incorrect connection to the power supply may result in an electric shock.

The mains cable must only be replaced by a qualified electrician.

When replacing the mains cable only use cable type H 05 VV-F with a suitable cross section. A suitable connection cable is available to order from Miele.

Wiring diagram

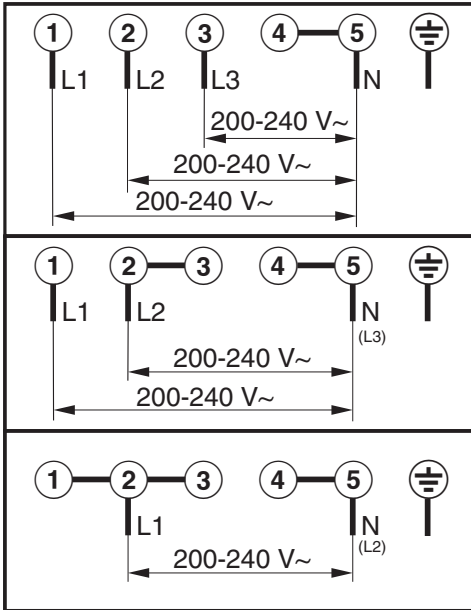

After sales service

Contact in the event of a fault

In the event of any faults which you cannot remedy yourself, please contact your Miele dealer or the Miele Customer Service Department.

You can book a Miele Customer Service Department call-out online at www.miele.com/service.

Contact information for the Miele Customer Service Department can be found at the end of this document.

Please quote the model identifier and serial number of your appliance (Fabr./SN/ Nr.) when contacting the Miele Customer Service Department. This information can be found on the data plate.

Please note that telephone calls may be monitored and recorded for training purposes and that a call-out charge will be applied to service visits where the problem could have been resolved as described in this booklet.

Data plate

Stick the extra data plate supplied with the appliance here. Make sure that the model number matches the one specified on the back cover of this document.

Warranty

For information on the appliance warranty specific to your country please contact Miele. See back cover for address.

In the UK, your appliance warranty is valid for 2 years from the date of purchase. However, you must activate your cover by calling 0330 160 6640 or registering online at www.miele.co.uk.

The following data sheets apply to the models described in this operating instruction manual.

Information for domestic electric hobs

In acc. with regulation (EU) No. 66/2014

MIELE	
Model name/identifier	KMDA 7476
Number of cooking zones and/or areas	4
For circular cooking zones: diameter of useful surface area/cooking zone For non-circular cooking zones or areas: length and width of useful surface area per electric cooking zone or area	1. = 230x460 mm 2. = 230x460 mm 3. = 4. = 5. = 6. =
Energy consumption per cooking zone or area calculated per kg ($EC_{\text{electric cooking}}$)	1. = 180,1 Wh/kg 2. = 180,7 Wh/kg
Energy consumption for the hob calculated per kg ($EC_{\text{electric hob}}$)	180,4 Wh/kg

Product data sheets

Data sheet for household cooker hoods

In acc. with delegated regulation (EU) No. 65/2014 and regulation (EU) No. 66/2014

MIELE	
Model name/identifier	KMDA 7476
Annual Energy Consumption (AEC_{hood})	27,6 kWh/year
Energy efficiency class	A++
Energy efficiency index (EEL_{hood})	36,4
Fluid Dynamic Efficiency (FDE_{hood})	36,5
Fluid Dynamic Efficiency class	
A (most efficient) to G (least efficient)	A
Lighting Efficiency (LE_{hood})	lx/W
Lighting Efficiency class	
A (most efficient) to G (least efficient)	-
Grease Filtering Efficiency	95,1 %
Grease Filtering Efficiency class	
A (most efficient) to G (least efficient)	A
Airflow at best efficiency point	316,2 m ³ /h
Air flow (min. speed)	160 m ³ /h
Air flow (max. speed)	490 m ³ /h
Air flow (intensive or boost setting)	580 m ³ /h
Max. air flow (Q_{max})	580 m ³ /h
Air pressure at best efficiency point	456 Pa
Airborne acoustical A-weighted sound power emissions (min. speed)	45 dB
Airborne acoustical A-weighted sound power emissions (max. speed)	69 dB
Airborne acoustical A-weighted sound power emissions (intensive or boost setting)	73 dB
Electrical power input at best efficiency point	109,9 W
Power consumption in off mode (P_o)	W
Power consumption in standby mode (P_s)	0,20 W
Nominal power of lighting system	0,0 W
Average illumination of the lighting system on the cooking surface	0 lx
Time increase factor	0,7

Miele hereby declares that this ceramic induction hob complies with Directive 2014/53/EU.

The complete text of the EU declaration of conformity is available from one of the following internet addresses:

- Products, Download from www.miele.co.uk
- For service, information, operating instructions etc: go to www.miele.co.uk/domestic/customer-information-385.htm and enter the name of the product or the serial number

Frequency band of the WiFi module	2.4000 GHz – 2.4835 GHz
-----------------------------------	-------------------------

Maximum transmitting power of the WiFi module	< 100 mW
---	----------

This **Statement of Compliance** confirms this Miele product fully complies with the **Product Security and Telecommunications Infrastructure (Security Requirements for Relevant Connectable Products) Regulations 2023**.

- 1) Household Appliance – *Induction hobs KMDA 7476*
- 2) Manufactured by: Miele & Cie KG,
Carl Miele Street 29, 33332 Gutersloh Germany
Imported by and contact point: Miele Company Ltd, Fairacres, Marcham Road, Abingdon, Oxon, OX14 1TW Great Britain
- 3) The defined support period at the time of first supply is 10 years
- 4) To report vulnerabilities and cybersecurity issues please contact: psirt@miele.com
- 5) Signature 
Name: **Paul Wright**
Company Position: **Head of Technical Management**
Date of signature: **19th March 2024**
Place of signature: **Abingdon, Oxfordshire**

United Kingdom

Miele Co. Ltd., Fairacres, Marcham Road, Abingdon, Oxon, OX14 1TW
Tel: 0330 160 6600, Internet: www.miele.co.uk/service, E-mail: info@miele.co.uk

Australia

Miele Australia Pty. Ltd.
ACN 005 635 398
ABN 96 005 635 398
1 Gilbert Park Drive
Knoxfield, VIC 3180
Tel: 1300 464 353
Internet: www.miele.com.au

China Mainland

Miele Electrical Appliances Co., Ltd.
1-3 Floor, No. 82 Shi Men Yi Road
Jing' an District
200040 Shanghai, PRC
Tel: +86 21 6157 3500
Fax: +86 21 6157 3511
E-mail: info@miele.cn
Internet: www.miele.cn

Hong Kong, China

Miele (Hong Kong) Ltd.
41/F - 4101, Manhattan Place
23 Wang Tai Road
Kowloon Bay, Hong Kong
Tel: (852) 2610 1025
Fax: (852) 3579 1404
Email:
customerservices@miele.com.hk
Website: www.miele.hk

India

Miele India Pvt. Ltd.
1st Floor, Copia Corporate Suites,
Commercial Plot 9,
Mathura Road, Jasola,
New Delhi - 110025
E-mail: customercare@miele.in
Website: www.miele.in

Ireland

Miele Ireland Ltd.
2024 Bianconi Avenue
Citywest Business Campus
Dublin 24
Tel: (01) 461 07 10
Fax: (01) 461 07 97
E-Mail: info@miele.ie
Internet: www.miele.ie

Malaysia

Miele Sdn Bhd
Suite 12-2, Level 12
Menara Sapura Kencana
Petroleum
Solaris Dutamas No. 1
Jalan Dutamas 1
50480 Kuala Lumpur, Malaysia
Phone: +603-6209-0288
Fax: +603-6205-3768

New Zealand

Miele New Zealand Limited
IRD 98 463 631
8 College Hill
Freemans Bay, Auckland 1011
New Zealand
Tel: 0800 464 353
Internet: www.miele.co.nz

Singapore

Miele Pte. Ltd.
29 Media Circle
#11-04 ALICE@Mediapolis
Singapore 138565
sTel: +65 6735 1191
Fax: +65 6735 1161
E-Mail: info@miele.com.sg
Internet: www.miele.sg

South Africa

Miele (Pty) Ltd.
63 Peter Place
Bryanston 2194
P.O. Box 69434
Bryanston 2021
Tel: (011) 875 9000
Fax: (011) 875 9035
E-mail: info@miele.co.za
Internet: www.miele.co.za

Thailand

Miele Appliances Ltd.
BHIRAJ TOWER at EmQuartier
43rd Floor Unit 4301-4303
689 Sukhumvit Road
North Klongton Sub-District
Vadhana District
Bangkok 10110, Thailand

United Arab Emirates

Miele Appliances Ltd.
Showroom 1
Eiffel 1 Building
Sheikh Zayed Road, Umm Al Sheif
P.O. Box 114782 - Dubai
Tel. +971 4 3044 999
Fax. +971 4 3418 852
800-MIELE (64353)
E-Mail: info@miele.ae
Website: www.miele.ae

Manufacturer: Miele & Cie. KG, Carl-Miele-Straße 29, 33332 Gütersloh, Germany

KMDA 7476 FR, KMDA 7476 FL

en-GB

M.-Nr. 11 837 411 / 01