

Miele



zh 操作說明 無線吸塵機

en Operating instructions Cordless vacuum cleaner

HS19

M.-Nr. 12 466 810

內容

警告和安全說明	4
AP 01/AP 02/AP 03 電池、LG 01/LG 02 充電器、LS 03 充電器底座（視乎型號）的安全說明和警告.....	6
電器指南	10
環保	12
安裝及連接.....	13
組裝吸塵機.....	13
單獨使用主機.....	13
連接 Comfort 手柄	13
連接主機到吸管	14
放入電池	14
連接電動吸頭.....	15
一般電池資料.....	15
電池充電（無壁掛式安裝）	16
電池充電（壁掛式安裝）	16
電池充電狀態指示器（充電時）	18
電池充電狀態指示器（使用中）	18
使用附帶的配件	19
吸管配件支架	19
Multi Floor XXL 電動吸頭	19
硬地板護理軟滾筒塵刷（HX HC）.....	20
額外的電池（HX LA）.....	20
使用	21
開啟和關閉.....	21
選擇吸力模式	21
照亮操作區域	21
暫停吸塵時的自立功能.....	21
保養	21
購買配件	22
過濾系統	22
啟用 ComfortClean 功能.....	22
清空集塵箱.....	23
清潔預過濾網和微塵過濾網	24
清潔集塵箱.....	25
清潔電動吸頭.....	26
更換充電池.....	26
錯誤訊息	27
排除故障	28

服務	30
故障時的聯絡方式.....	30
保養	30
阿聯酋（UAE）的保養.....	30
清潔與護理.....	30
可選配件	31
購買配件	31

警告和安全說明

本吸塵機符合現有安全要求。使用不當可導致人身傷害和財產損失。

在首次使用本吸塵機之前，請仔細閱讀操作和安裝說明。其中包含關於本吸塵機的安全、使用和保養的重要資訊。它可以防止出現人身傷害和電器損壞。

根據 IEC 60335-1 的標準，Miele 明確及強烈建議您閱讀並遵循“安裝及連接”一節以及安全須知中的警告說明。

因未遵守這些說明而導致的傷害或損壞，Miele 概不負責。

請妥善保存這些說明，並將它們交給日後的機主。

用完吸塵機後，在更換任何零件以及進行保養、清潔和排除故障之前，請務必將切斷電源。使用 Comfort 手柄上的開/關按鈕來完成上述動作。

正確用法

- ▶ 本吸塵機適用於清潔家庭地板及類似的工作和居住環境。本吸塵機不適用於建築工地。
- ▶ 本吸塵機不適合在戶外使用。
- ▶ 本吸塵機可用於為地毯、毛毯和堅固硬地板進行常規清潔。
- ▶ 本吸塵機適合在海平面高度在 4000 米以上的地方使用。
- ▶ 本吸塵機只可用於為乾燥地板表面吸塵。不得對人或動物吸塵。不得用於任何其他用途、改造或改裝。
- ▶ 本吸塵機不適合身體、感官或心智不健全者，或缺乏經驗與知識的人（包括兒童）使用，除非他們在使用時有人監督，或已知曉如何以安全方式使用，且理解並認識到不正確操作所導致的後果。

兒童安全

- ▶ 有窒息危險。例如塑膠袋等包裝物料必須放在嬰兒和兒童無法觸及的地方。玩耍時，孩子們可能會意外被包裝纏住，或誤將其拉到頭上導致窒息。
- ▶ 8 歲以下兒童必須遠離吸塵機，除非一直有人看管他們。

- ▶ 8 歲和以上的兒童若在無人看管的情況下使用吸塵機，必須向他們演示如何安全使用吸塵機。兒童必須能夠理解並認識到不正確操作可能帶來的危險。
- ▶ 兒童不得在無人看管的情況下清潔或保養本吸塵機。
- ▶ 請看管好在吸塵機附近的兒童，不要讓他們玩弄吸塵機。

技術安全

- ▶ 吸塵機以 25.2 伏特運作。
它被分類為第 II 類電器，在結構上設計為第 III 類電器。
本電器由安全特低電壓（SELV）電源供電，低電壓電源能夠保護用戶免受電擊危險。第 II 類充電器用來供電，為吸塵機充電。
- ▶ 比較充電器資料牌上的連接資料（電壓與頻率）與市電電源的資料。確保兩者資料相吻合。本充電器適用於 50 赫茲和 60 赫茲，無需改動。
- ▶ 電源插頭必須裝有適當的保險絲。
- ▶ 使用前，請檢查吸塵機及其所有配件是否有明顯的損壞痕跡。切勿使用損壞的吸塵機或損壞的配件。
- ▶ Miele Multi-Floor XXL 電動塵刷和 Miele 手提式迷你電動吸頭（因型號而異）是專門為本 Miele 吸塵機設計的電動裝置。出於安全原因，請勿將吸塵機與不同的 Miele 電動吸頭/手提式吸頭，或其他製造商生產的電動吸頭/手提式吸頭一併使用。
- ▶ 使用前和使用期間，請確保在電動吸頭的底部/手提式吸頭*（*視乎型號）的底部沒有/沒有被夾雜的粗塵或碎屑。
- ▶ 將吸塵機與所有配件存放在 0 °C 至 45 °C 之間的环境溫度中。
- ▶ 吸塵機保養期內，只能由 Miele 授權的維修技術人員進行維修。否則保養無效。
- ▶ 維修只能由 Miele 授權的維修技術人員進行。由未經授權人士進行維修或其他工序可能會給使用者帶來相當大的危險。

警告和安全說明

正確使用

- ▶ 若未安裝集塵箱、預過濾網和微塵濾網，請勿使用吸塵機。
- ▶ 不要用吸塵機向任何已經燃燒或仍在發光的東西吸塵，例如香煙、灰燼或煤炭，不論正在發光還是看來已熄滅。
- ▶ 請勿用吸塵機吸水、液體或沾濕的泥土。剛清潔或洗過的地毯或毛毯應等待完全乾透後，再嘗試吸塵。
- ▶ 請勿用吸塵機吸碳粉。碳粉（例如打印機和影印機中使用的碳粉）可以導電。
- ▶ 請勿對任何易燃或可燃的液體或氣體吸塵，也不要儲存此類物品的區域吸塵。
- ▶ 旋轉時，切勿觸摸電動吸頭/手提式吸頭（因型號而異）。
- ▶ 不要在齊頭高度使用電動吸頭/手提式吸頭（因型號而異）。
- ▶ 不要在齊頭高度吸塵，也不要任何人的頭部附近吸塵。

AP 01/AP 02/AP 03 電池、LG 01/LG 02 充電器、LS 03 充電器底座（視乎型號）的安全說明和警告

兒童安全

- ▶ 身體、感官或心智不健全者，或缺乏經驗與知識的人士（包括兒童）若未能安全使用 LG 01/LG 02 充電器或 LS 03 充電器底座，除非他們在使用時有人監督，或已知曉如何以安全方式使用，且理解並認識到不正確操作所導致的後果，才能使用本吸塵機。
- ▶ 將 AP 01/AP 02/AP 03 電池存放於兒童無法觸及的地方。
- ▶ 兒童必須遠離 LG 01/LG 02 充電器和 LS 03 充電器底座，除非一直有人看管他們。

技術安全

▶ AP 01/AP 02/AP 03 電池、LG 01/LG 02 充電器和 LS 03 充電器底座旨在與 Miele HS 19 吸塵機配合使用。出於安全原因，請勿將吸塵機與其他製造商生產的電池、充電器或充電器底座一併使用。

▶ 僅隨附的 LG 01/xx 或 LG 02/xx 充電器，或隨附的或作為配件購買的 LS 03/xx 充電器底座可用來為 AP 01/AP 02/AP 03 電池充電。

xx 代表 01、02、03、04、05、06、07 或 08；這些數字用來確定您的 LG 01/LG 02 充電器和您的 LS 03 充電器版本：

XX	LG 01/LS 03	LG 02
01	AT, BE, BG, CH, CL, CZ, DE, DK, EE, ES, FI, FR, GR, HR, HU, IT, KZ, LT, LU, LV, NL, NO, PL, PT, RO, RS, RU, SE, SI, SK, TR, UA, ZA	AT, BE, BG, CH, CL, CZ, DE, DK, EE, ES, FI, FR, GR, HR, HU, IT, KZ, LT, LU, LV, NL, NO, PL, PT, RO, RS, RU, SE, SI, SK, TR, UA, ZA
02	AE, GB, HK, IE, MY, SG	AE, HK, IE, MY, SG
03	CA, MX, US	CA, J, MX, US
04	AU, NZ	AU, NZ
05	CN	CN
06	KR	KR
07	JP	UK
08	IN	

▶ 使用電源插座轉接器時，請確保該轉接器可以持續運作。

▶ 可以在自主供電系統或與主電源不同步的供電系統（如島嶼網絡、後備系統）上臨時或永久運行。操作的先決條件是電源系統符合 EN 50160 或同等標準的規格。

在隔離運行或與主電源不同步的運行中，亦必須保持家用電氣裝置和該 Miele 產品中所提供的保護措施的功能和運行，或這些措施必須由裝置中的同等措施取代。例如，在當前版本的 BS OHSAS 18001-2 ISO 45001 中所述。

▶ 在 0 °C 至 45 °C 之間的環境溫度中為電池充電和使用電池。在此環境溫度範圍以外使用電池會使其性能受限。

警告和安全說明

- ▶ 如果您發現 AP 01/AP 02/AP 03 電池發出異常氣味、有液體洩漏、明顯過熱、變色或變形，請立即停止使用。立即棄置 AP 01/AP 02/AP 03 電池（請參閱本章末尾的安全注意事項"棄置 AP 01/AP 02/AP 03 電池"以及"環保" – "棄置舊電池"）。
- ▶ 電池會隨著時間耗盡。它們其後可能會洩漏腐蝕性液體。避免接觸眼部及皮膚。接觸時，用水徹底沖洗並就醫。
- ▶ AP 01/AP 02/AP 03 鋰離子電池受危險品法規約束。允許用戶透過道路運輸 AP 01/AP 02/AP 03 電池，而無需遵循任何其他要求。寄送 AP 01/AP 02/AP 03 電池前，請先聯絡 Miele 客戶服務部門。僅可寄送未損壞且電量完全耗盡的 AP 01/AP 02/AP 03 電池。用膠紙將金屬觸點絕緣，以防止短路。以 AP 01/AP 02/AP 03 電池無法在包裝內移動的方式將其包裝。

正確使用

- ▶ 請勿丟下或拋擲 AP 01/AP 02/AP 03 電池。出於安全原因，請勿繼續使用已損壞的 AP 01/AP 02/AP 03 電池。
- ▶ AP 01/AP 02/AP 03 電池需遠離明火或其他熱源。請勿加熱 AP 01/AP 02/AP 03 電池。請勿將充電池直接暴露在陽光下。
- ▶ 請勿拆卸 AP 01/AP 02/AP 03 電池。
- ▶ 請勿無意或故意橋接 AP 01/AP 02/AP 03 電池的觸點而引發短路。
- ▶ AP 01/AP 02/AP 03 電池不得接觸液體。
- ▶ 棄置 AP 01/AP 02/AP 03 電池：從吸塵機中取出 AP 01/AP 02/AP 03 電池。用膠紙將金屬觸點絕緣，以防止短路。將 AP 01/AP 02/AP 03 電池拿到市政回收設施。請勿將 AP 01/AP 02/AP 03 電池與家居垃圾一起處理。

清潔

- ▶ 請勿將吸塵機或隨附的任何配件浸入水中。
- ▶ 電動吸頭/手提式吸頭（取決於型號）、主機、吸管、主機和 Comfort 手柄均包含電線。插頭連接器不得碰水。有觸電危險。僅應使用乾布清潔。
- ▶ 清潔吸塵機及配件時應先斷開連接電源，然後用乾布或微濕布清潔。例外：
 - 集塵器：清空集塵器並移除預過濾網。僅用清水和溫和清潔液清潔集塵器。之後小心拭乾集塵器。更換集塵器內的預過濾網。

配件和零件

- ▶ 僅使用包裝上有“ORIGINAL Miele”標誌的原裝配件。否則製造商不能保證產品的安全性。
- ▶ Miele 只能在使用 Miele 原裝零件時保證電器的安全性。只能使用 Miele 原裝零件更換其故障組件。

運輸

- ▶ 包裝物料可保護吸塵機避免在運送途中損壞。我們建議您保留包裝以便運送。

電器指南

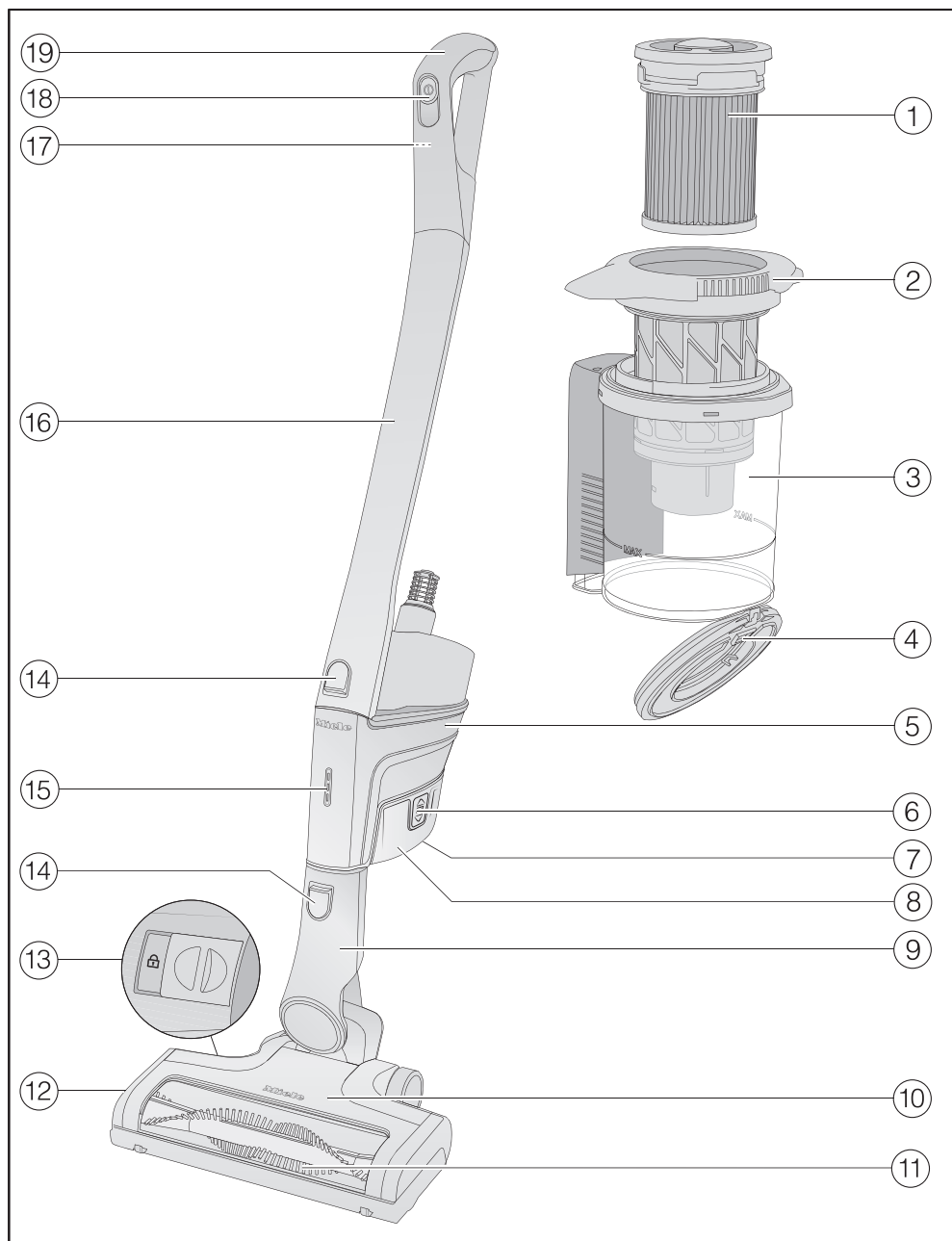

- ① 微塵濾網 (HX FSF-2)
- ② 預過濾網
- ③ 集塵箱
- ④ 集塵箱擋板
- ⑤ 主機底部有一電池連接以及吸管和電動吸頭的連接器，在頂部有一吸管和 Comfort 手柄的連接器
- ⑥ 電池的鎖釦（在電池兩側）
- ⑦ 充電插座（電池底部）
- ⑧ AP 01/AP 02/AP 03 鋰離子電池 (HX LA)
- ⑨ 電動吸頭連接器
- ⑩ Multi Floor XXL 電動吸頭（部分型號帶有 BrilliantLight 照明）
- ⑪ 可拆卸滾筒塵刷
- ⑫ 擋板
- ⑬ 解鎖電動吸頭的鎖扣
- ⑭ 鎖釦
- ⑮ 電池充電狀態指示器
- ⑯ 吸管
- ⑰ Comfort 手柄的鎖釦（在背面）
- ⑱ 配有吸力選擇按鈕的開/關按鈕
- ⑲ Comfort 手柄

可持續性和環保

處置包裝材料

包裝材料用於搬運，保護設備不受運輸損壞。所用的包裝材料選自對環境無害的處置材料，一般可回收利用。

回收包裝材料可以減少原材料的使用。對有價值的材料使用特定的材料收集點，並利用退回選項。

我們建議保留包裝材料以備運輸之用。

棄置您的舊電器

在棄置舊吸塵機之前，請先移除細微粉塵濾網，然後與家居垃圾一起丟棄。

電器和電子設備通常包含許多重要材料。它們還含有對其正常運作和安全性至關重要的特定材料、化合物和組件。如果與普通垃圾一起處理或處理不當，可能對您的健康和環境有害。因此，請勿將舊吸塵機與家居垃圾一同棄置。



相反，請在當地社區官方指定的收集和處理點與您的經銷商或 Miele 一同處理和回收電器和電子設備。請確保您的舊吸塵機在等待處理的存放期間不會對兒童造成危險。

棄置舊電池

在許多情況下，電氣和電子裝置內置的電池在使用後不得與生活垃圾一起處理。您有法律義務（視國家/地區而定）移除所有未用吸塵機牢固密封的舊電池，並將其帶到適當的收集點（例如，零售商），以便免費將其交出。用膠紙將金屬觸點絕緣，以防止短路。電池中可能含有對人體健康和環境有害的物質。

電池上的標籤將提供更多資訊。帶叉號的垃圾桶符號表示不得將電池以生活垃圾形式棄置。有叉號的垃圾桶上還帶有一個或多個化學符號，表示電池包含鉛（Pb）、鎘（Cd）和/或水銀（Hg）。



舊電池包含可回收的寶貴原材料。分開處理電池可以使它們更易於處理和回收。

安裝及連接

組裝吸塵機

您可以 2 種不同的方式組裝吸塵機。

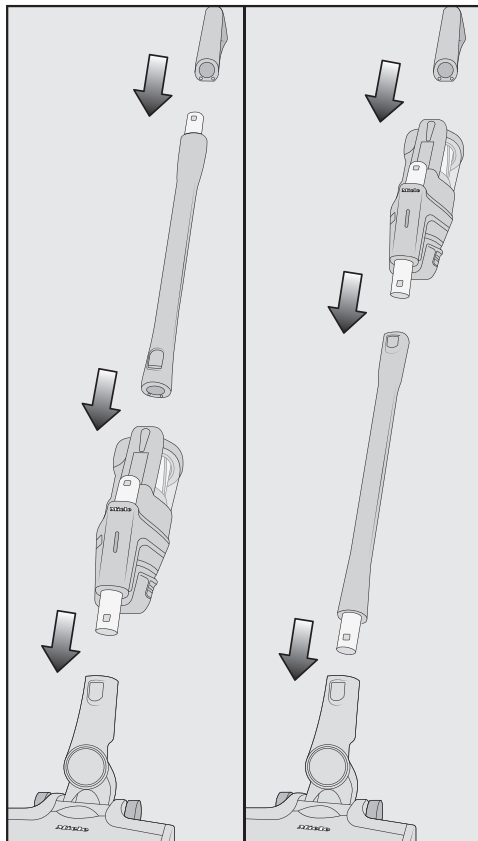

- 您可以將吸管放在主機的上方或下方。

請務必完全按照示意圖中所示組裝吸塵機。

吸塵機底部放置主機的優點如下：

- 實現自立功能（請參閱“使用”-“暫停吸塵時的可自立功能”）
- 人體工程學（減輕手腕上的壓力）
- 方便大範圍清潔

吸塵機頂部放置主機的優點如下：

- 方便清潔家具底下
- 可以快速卸下主機

單獨使用主機

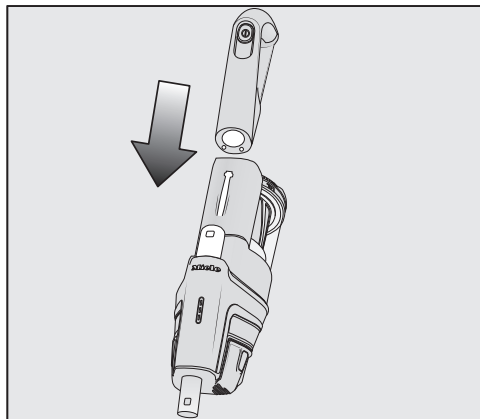

主機可以單獨使用，無需吸管和電動塵刷，可以快速清理特定區域的碎屑和絨毛。

提示：此配置特別適合使用三件套裝的情況（請參閱“使用包含的配件”）。

連接 Comfort 手柄

根據您決定吸塵機的配置方式，您可以將 Comfort 手柄連接到吸管或主機。

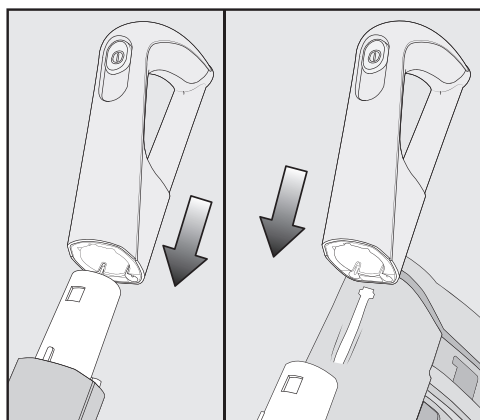

- 從上方將 Comfort 手柄向下推至吸管接口，直到聽到咔嗒一聲便可（詳情參閱左圖）。
- 從上方沿著集塵箱手柄上的引導線滑下 Comfort 手柄到主機接口上，直到聽到咔嗒一聲便可（詳情參閱右圖）。
- 如果您想分離各部分，請使用 Comfort 手柄正面的開/關按鈕關閉吸塵機。

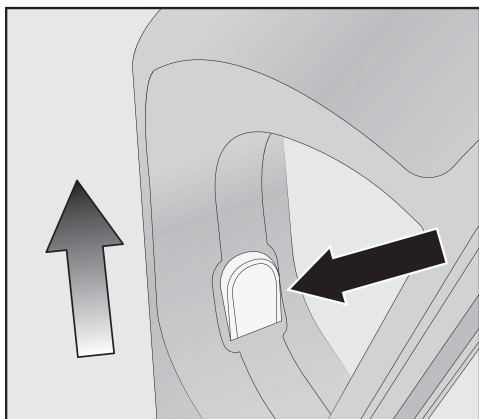

- 按下鎖扣，然後向上拉動以卸下 Comfort 手柄。

連接主機到吸管

根據您決定吸塵機的配置方式，吸管應放在主機的上方或下方。

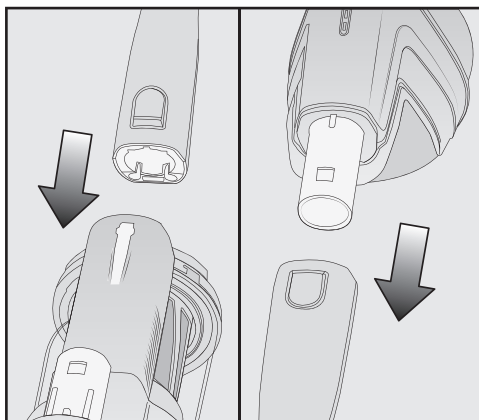

- 從上方沿著集塵箱手柄上的引導線滑下吸管到主機接口上，直到聽到咔嗒一聲便可（詳情參閱左圖）。
- 從上方將主機接口推入吸管，直到聽到咔嗒一聲便可（詳情參閱右圖）。

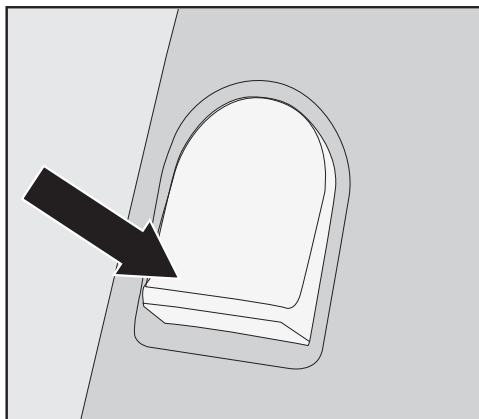

- 按下鎖扣以分離各部分。

放入電池

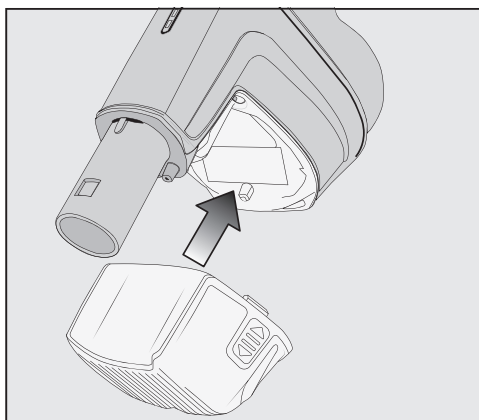

- 將電池沿引導線推入主機，直到聽到咔嗒一聲便可。

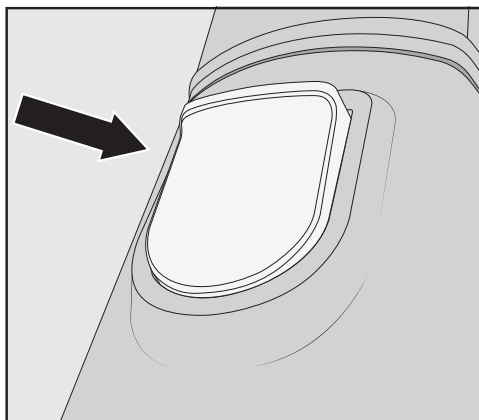
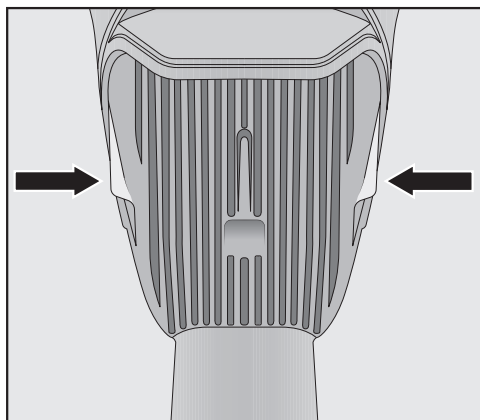

- 如果想再次分開兩部分，按下電池兩側的鎖扣，以取出電池。

- 為分離各部分，按下電動吸頭的鎖扣，將接口抽離電動吸頭。

連接電動吸頭

根據您決定吸塵機的配置方式，您可以將主機接口或吸管接口連接到電動吸頭。

一般電池資料

隨附的充電電池未完全充滿電。在首次使用前請將電池充滿。過程需時約 4 小時。
如要啟用電池，務必在主機中為電池進行首次充電。

電池充滿電後，主機上的電池充電狀態指示器會關閉，以節省能源。

僅當電池已充電並且電量耗盡五次後，才能達到最大充電容量。

如果吸塵機在完全組裝的狀態下以最大吸力模式使用，則充滿電後的電量可供您使用 14 分鐘。
但是，如果您單獨使用主機，並選擇最低吸力模式，則一次最長可以吸塵 60 分鐘。

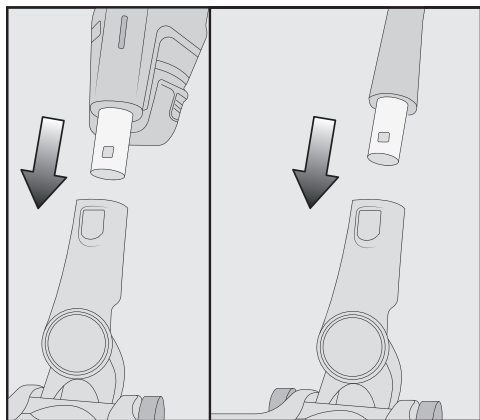

- 從上方將接口向下推入電動吸頭，直到聽到咔嗒一聲便可。

電池充電（無壁掛式安裝）

您可以將吸塵機豎直放置，並直接進行電池充電。

電池首次充電之前，請務必閱讀“安裝及連接”-“一般電池資料”中的資訊。

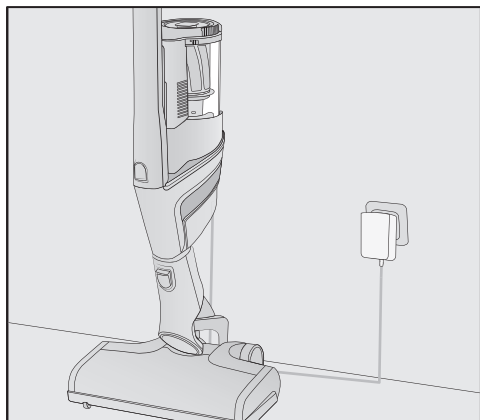

- 將主機連接到電動吸頭，為吸塵機提供牢固的底座。
- 向前擺動吸塵機，直到聽到電動吸頭接口發出咔嗒一聲便可。
- 將隨附的充電線插入電池底部的充電插座。
- 將充電器插入電源插座。

充電程序將開始。

詳情請參閱“電池充電狀態指示器（充電中）”。

電池充電（壁掛式安裝）

有 2 種方法可以在隨附的壁掛支架中儲存和充電吸塵機。

電池首次充電之前，請務必閱讀“安裝及連接”-“一般電池資料”中的資訊。

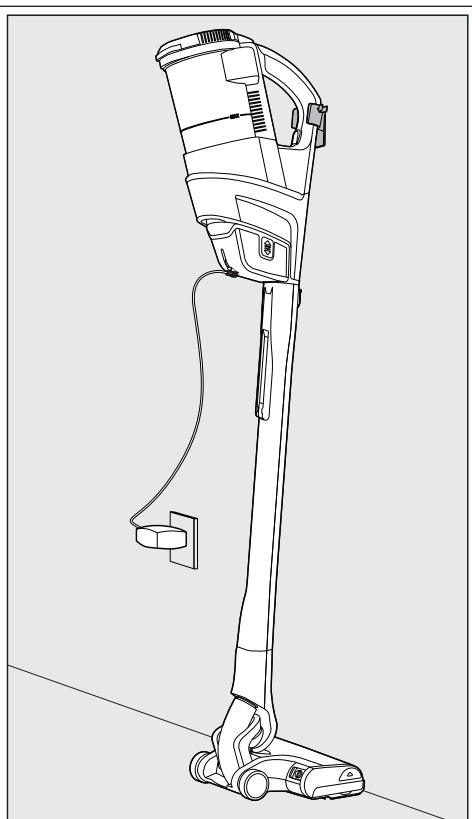

您需要在可供使用的電源插座附近的合適位置將電器安裝在牆上。

固定安裝板

隨附 2 個插頭和 2 個 T20 TORX 螺絲以在牆上固定安裝板。

您還需要電動螺絲刀或電鑽（鑽頭直徑為 6 毫米）。

根據您決定吸塵機的配置方式，在安裝板的底部邊緣和地板之間取 45 厘米或 98 厘米的距離。

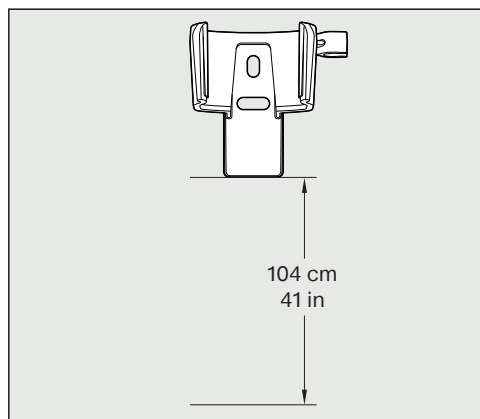

注意不要損壞牆上鋪設的任何電纜。

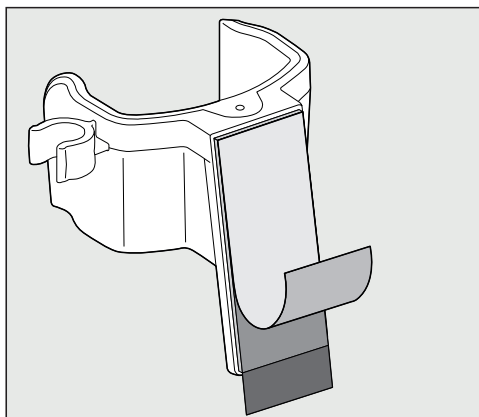

■ 將安裝板固定到牆上。

注意不要損壞牆上鋪設的任何電纜。

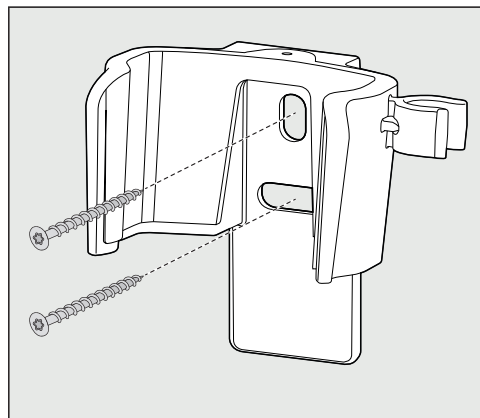

■ 將安裝板固定到牆上。

固定安裝板

隨附 2 個插頭和 2 個 T20 TORX 螺絲以在牆上固定安裝板。
您還需要電動螺絲刀或電鑽（鑽頭直徑為 6 毫米）。

根據您決定吸塵機的配置方式，在安裝板的底部邊緣和地板之間取 45 厘米或 98 厘米的距離。

連接壁掛支架

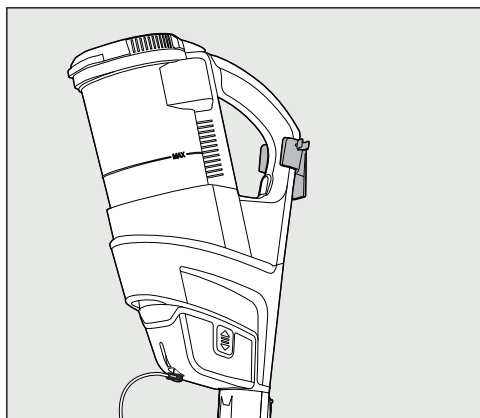

- 從上方將壁掛支架向下推入安裝板，直到聽到咔嗒一聲便可。
- 從上方將已放入電池的完整組裝吸塵機的主機向下推入壁掛支架。
- 將充電器插入電源插座。

充電程序將開始。

電池充電狀態指示器 (充電時)

電池充電狀態在主機上顯示。

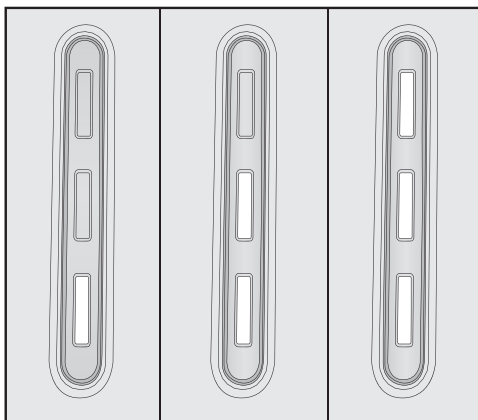

充電容量

約 0–34 %

約 35–69 %

約 70–90 %

約 91–99 %

100 %

顯示屏

底部照明緩慢閃爍

底部照明亮起；中間照明緩慢閃爍

底部及中間照明亮起；頂部照明緩慢閃爍

底部、中間及頂部照明亮起

顯示屏關閉

電池充滿電後，電池充電狀態指示器會關閉，以節省能源。

如果電池長時間不使用並且電量耗盡，則會進入安全模式。因此，在主機中充電時，電池充電狀態指示器會在大約 30–60 分鐘後開始運作。

電池充電狀態指示器 (使用中)

電池充電狀態在主機上顯示。

充電容量

顯示屏

約 100-70 %	頂部、中間及底部照明亮起
約 69-35 %	中間及底部照明亮起
約 34-15 %	底部照明亮起
約 14-0 %	底部照明緩慢閃爍

我們建議讓電池電量完全耗盡後再充電。這樣，您將獲益與於電池的全部電量。

使用附帶的配件

Miele 為許多特殊應用提供一系列合適的配件（請參閱“自選配件”）。

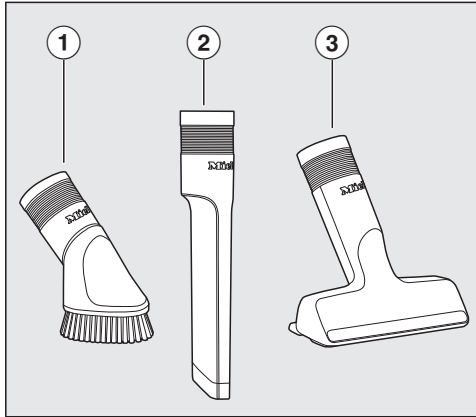

- 1 除塵刷**
用於吸腳線蓋板、雕刻家具或裝飾品的配件。
- 2 罅隙吸咀**
用於清潔狹縫、罅隙或角落的配件。
- 3 傢俱布料吸咀**
用於清潔傢俱布料、床褥及枕頭的配件。

吸管配件支架

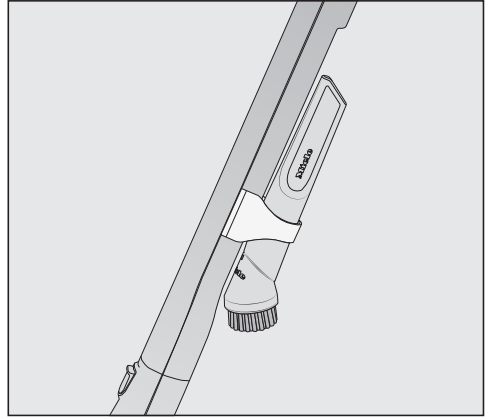

使用此配件支架，您可以在吸塵時攜帶三件配件套裝中的 2 個配件。

Multi Floor XXL 電動吸頭

請遵從地板製造商的清潔和保養說明。

! 因被困住的材料導致損壞。
刮擦地板的風險。
確保電動吸頭底部沒有被夾雜的粗塵或碎屑，例如碎片或石子。

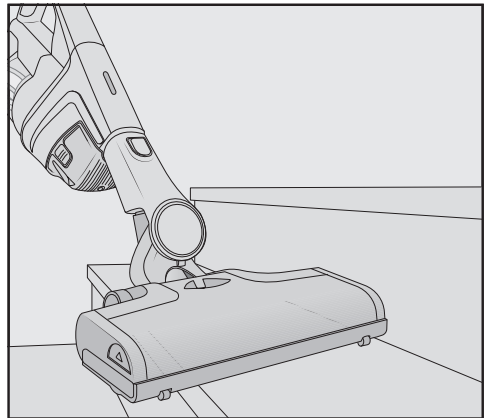

電動吸頭可用於為地毯、毛毯和硬地板的日常清潔。

提示: 吸管不是清潔地毯樓梯的便捷選擇。

提示: 如果您需要清理大量的粗塵或碎屑，請單獨使用主機（請參閱“安裝和連接”-“單獨使用主機”）。

硬地板護理軟滾筒塵刷 (HX HC)

（視乎型號）

請遵從地板製造商的清潔和保養說明。

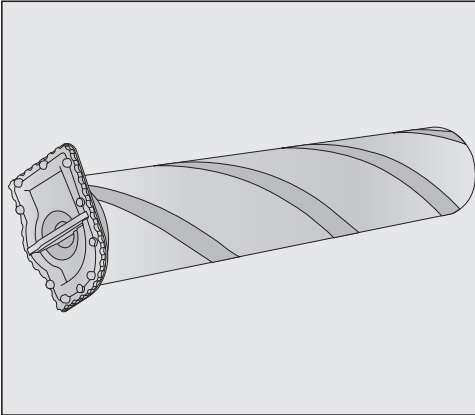

當安裝硬地板護理軟刷時，電動吸頭可以用於清潔精緻的硬地板。

將硬地板護理軟刷插入電動吸頭，替代標配安裝的滾筒塵刷。

當您使用硬地板護理軟滾筒塵刷時，電動吸頭的功耗會自動設置為最佳水平 - 這會導致運行噪音的變化。

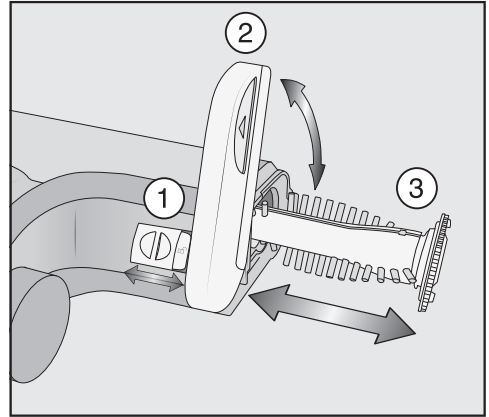

- 鬆開電動吸頭側面的遮蓋，露出  符號 ①。
- 儘量提起遮蓋 ②。
- 取下標配安裝的滾筒塵刷 ③。
- 插入硬地板護理滾筒塵刷。
- 蓋上並鎖上蓋子。

額外的電池 (HX LA)

（視乎型號）

使用額外的電池會使吸塵機的運作時間增加一倍。

首次充電之前，請務必閱讀“安裝及連接”-“一般電池資料”中的資訊。

使用

開啟和關閉

- 如果您在壁掛支架中為電池充電，請將吸塵機從壁掛支架中取出。
- 如果您直接給電池充電，請從電池底部的充電插座上拔下充電器的插頭。

為了獲得最佳清潔效果，請始終在打開吸塵機之前啟動 ComfortClean 功能（請參閱“保養”-“啟動 ComfortClean 功能”）。

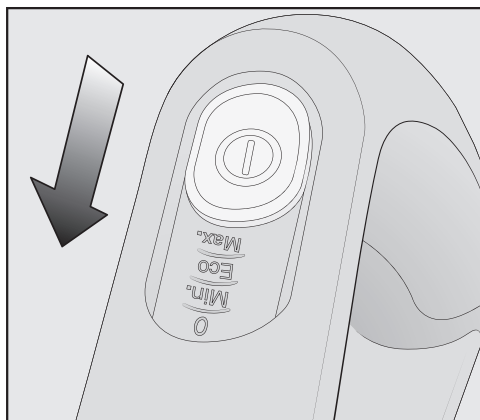

- 在 Comfort 手柄按下開/關按鈕 ①。

選擇吸力模式

吸力模式可根據具體情況進行調整。降低吸力會減少操作電動吸頭所需的力度。

Comfort 手柄上有 3 種吸力模式可供選擇：

- | | |
|-----|--------------|
| 最低 | 最低吸力模式適合輕微骯髒 |
| Eco | 中等吸力模式適合一般骯髒 |
| 最高 | 最高吸力模式適合嚴重骯髒 |

地板感應功能可在每一種吸力模式中啟動。

根據地板的類型和使用的滾筒塵刷，電動吸頭的功耗會自動設置為最佳水平 - 這會導致運行噪音的變化。

照亮操作區域

（視乎型號）

您吸塵機的電動吸頭配有 BrilliantLight 照明，可照亮操作區域。

暫停吸塵時的自立功能

（出於安全原因，僅當主機安裝在吸塵機底部時才能使用此功能）

如果使用吸塵機底部安裝的主機吸塵，則可以在開啟電器電源時輕鬆中斷操作。

- 向前擺動吸塵機，直到聽到電動吸頭接口發出咔嗒一聲便可。

吸塵機牢固地保持豎立狀態，電動吸頭會自行關閉電源，節省電池電力。如果您隨後解鎖電動塵刷上的接口，則電動吸頭將再次啟動。

保養

⚠ 旋轉中的滾筒塵刷會構成受傷風險。

旋轉中的滾筒塵刷可能會讓您受傷。在進行任何維護工作之前，請關閉吸塵機。使用 Comfort 手柄上的開/關按鈕來完成上述動作。

我們建議只使用包裝上有“ORIGINAL Miele”標誌的原裝 Miele 塵袋、濾網和配件。只有這樣才能保證您的吸塵機發揮最佳性能並獲得最佳清潔效果。

請注意，因使用了在包裝上沒有“ORIGINAL Miele”標誌的配件所造成的故障和損壞，不在吸塵機保養範圍之內。

購買配件

Miele 原裝配件可從 Miele 網上商店、Miele 客戶服務部或 Miele 經銷商處訂購。

原裝 Miele 配件的包裝上有“ORIGINAL Miele”標誌。



憑藉 3D4U，Miele 還提供免費配件供您的 3D 印表機下載（www.miele.com，服務，3D4U）。



3 D 4 U

過濾系統

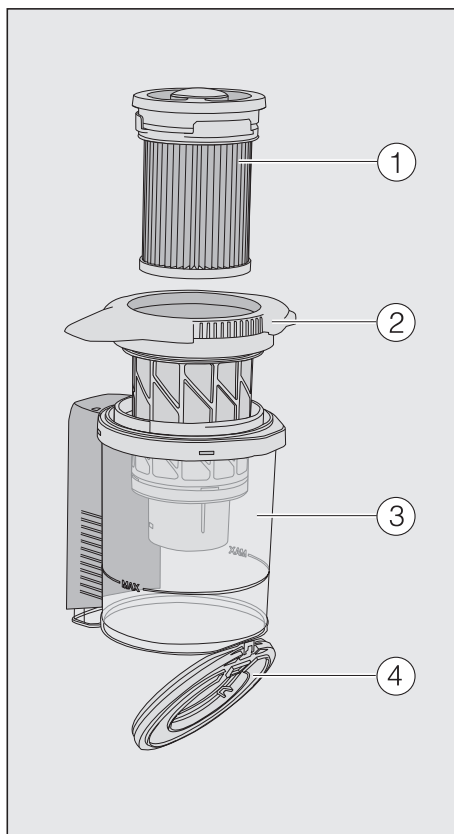

- ① 微塵濾網 (HX FSF-2)
- ② 預過濾網
- ③ 集塵箱
- ④ 集塵箱擋板

啟用 ComfortClean 功能

在清空集塵箱之前，請始終對微塵濾網運行臨時清潔功能。每當吸力開始下降時，也應該運行它。

這使吸塵機能夠立即再次獲得最佳的清潔性能。

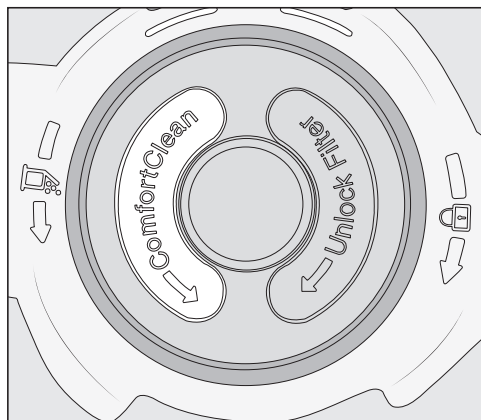

- 微塵濾網在集塵箱的蓋內。逆時針旋轉 180°，旋轉 3 圈。使用凹槽來幫助您。

您會聽到操作噪音，這是 ComfortClean 功能的正常運行。

清空集塵箱

最遲在灰塵達到集塵箱上的**最大容量標記**之前，清空集塵箱。

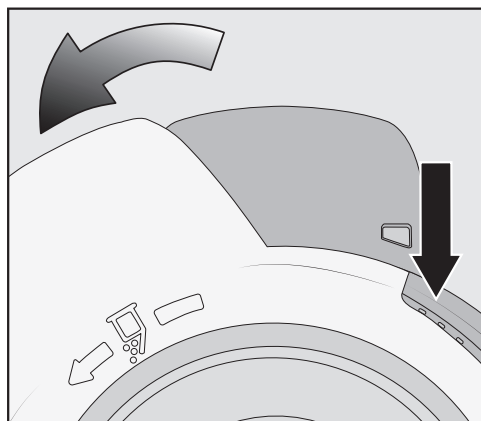

- 沿箭頭方向，將集塵箱的遮蓋旋轉至第一擋。使用灰色的抓握表面可以幫助您完成此操作。

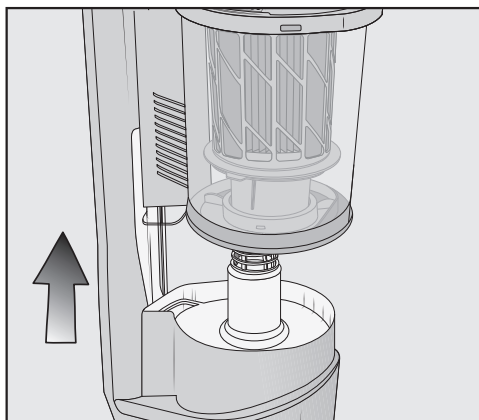

- 向上提起集塵箱將其取出。

只要無禁止物質，集塵箱中的內容物就可以與普通家庭垃圾一起處理。

- 將集塵箱拿近垃圾箱，以防止灰塵倒瀉出來。

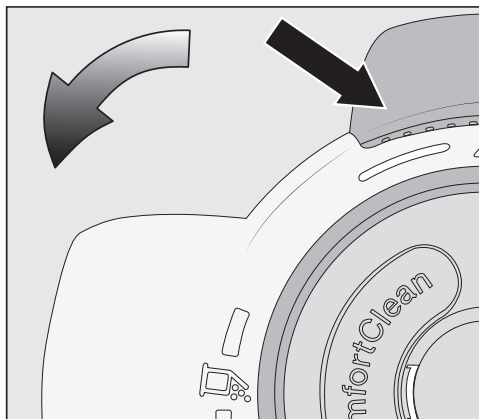

- 沿箭頭方向，將集塵箱的遮蓋旋轉至下一擋。使用灰色的抓握表面可以幫助您完成此操作。

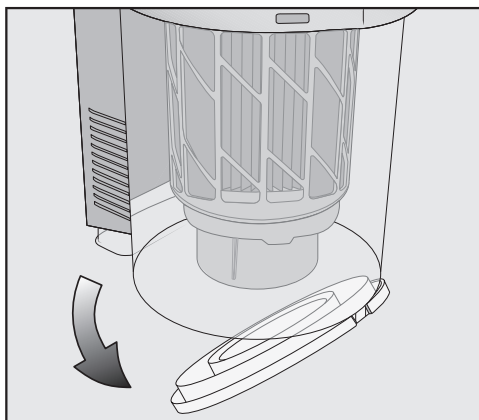

集塵箱擋板會打開將灰塵掉落。

如果沒有大塊的灰塵、毛髮或粗碎屑掉落，請向上拉動預過濾網（請參閱下方的“清潔預過濾網和微塵濾網”）。

- 將集塵箱的遮蓋轉回到原位。
- 關上集塵箱擋板，確保其卡入就位。

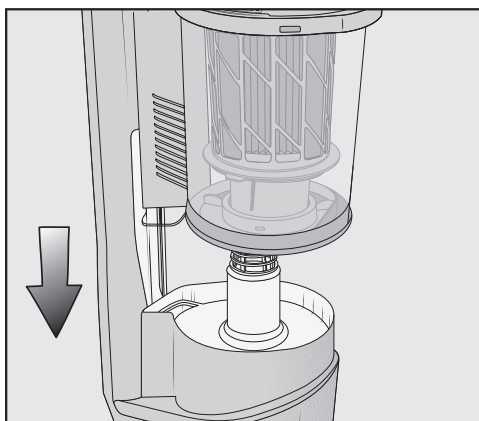

- 從上方沿著引導線滑下集塵器手柄到主機接口上，直到聽到集塵箱咔嗒一聲便可。

清潔預過濾網和微塵過濾網

每 3 個月至少徹底清潔一次兩個過濾網。

清潔時，必須按照所述順序執行以下步驟。

- 取出集塵箱。
- 在垃圾桶上方清空集塵箱。

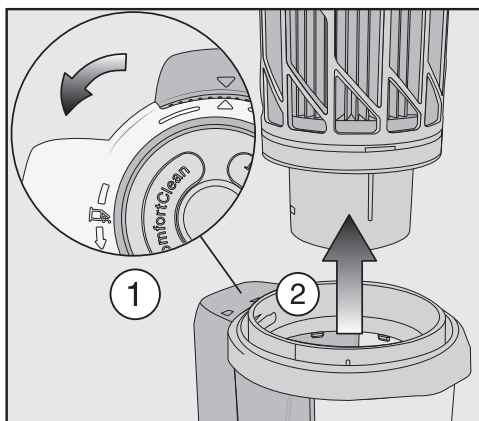

- 將集塵箱蓋子旋轉至停止位置，直到箭頭尖端對準頂部 ①。
- 向上拉起將預過濾網取出 ②。

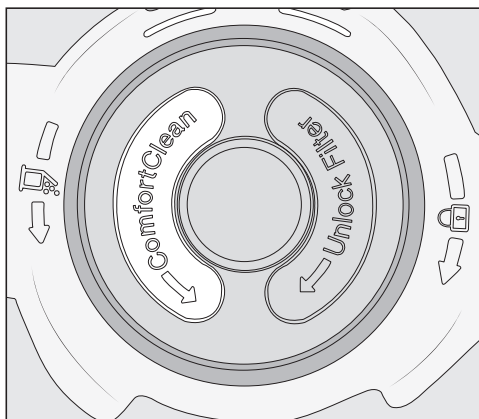

- 逆時針旋轉微塵濾網 180°，旋轉 10 圈。使用凹槽來幫助您。

您會聽到操作噪音，這是 ComfortClean 功能的正常運行。

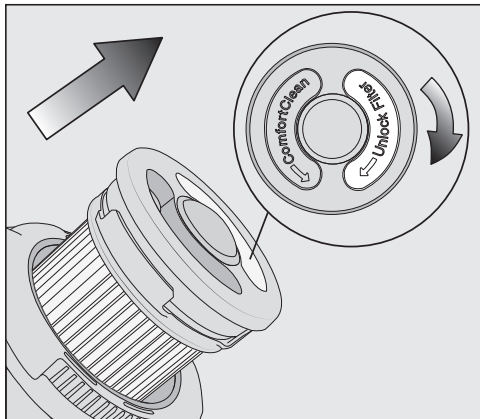

- 逆時針旋轉微塵濾網。使用凹槽來幫助您。
- 取出微塵濾網。

⚠ 清潔不當可導致損壞風險。
細小粉塵濾網可能會損壞，效能會因而降低。
請勿用水清潔微塵濾網，並且應避免清潔器內部。請勿使用尖銳或鋒利物體清潔濾網。請勿擦拭微塵濾網。

- 將微塵濾網拿在垃圾箱上方。
- 小心敲打橡膠底邊以清空微塵濾網。
- 進行此操作時，請輕輕轉動微塵濾網，以清除所有縫隙中的污垢。

⚠ 清潔不當可導致損壞風險。
預過濾網可能會損壞，效能會因而降低。
請勿用水清潔預過濾網。請勿使用尖銳或鋒利物體清潔濾網。

- 使用隨附的除塵刷或乾布清潔預過濾網。
- 清潔微塵濾網和預過濾網後，透過將微塵濾網頂部的圓帽向下壓到底，將前者重新插入後者。

為了繼續達到最佳的清潔效果，約 3 年後便要更換新的微塵濾網 (HX FSF-2)。

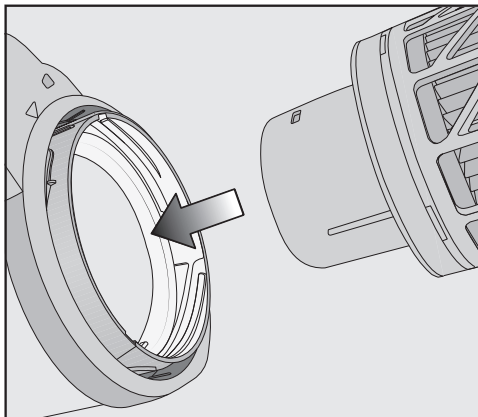

- 重新插入集塵箱內的預過濾網。

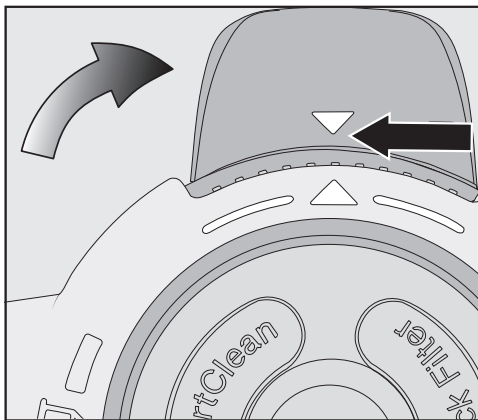

- 為此，請對齊引導線（箭頭），將預過濾網轉回到原位。
- 關上集塵箱擋板，確保其卡入就位。
- 重新將集塵箱連接至主機接口。

清潔集塵箱

按指引清潔集塵箱。

- 取出集塵箱。
- 在垃圾箱上方清空集塵箱，並向上提起預過濾網將其取出。

- 僅用清水和溫和清潔液清潔集塵箱。
- 徹底拭乾集塵箱。
- 將預過濾網重新插入集塵箱，然後將預過濾網轉回至其初始位置。
- 重新將集塵箱連接至主機接口。

清潔電動吸頭

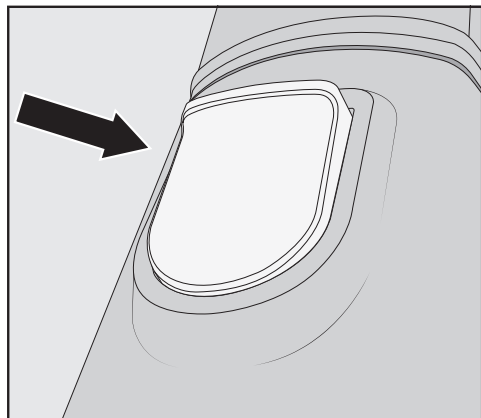

- 將電動吸頭與吸塵機斷開。
- 將電動吸頭倒置在水平、乾淨的表面上。

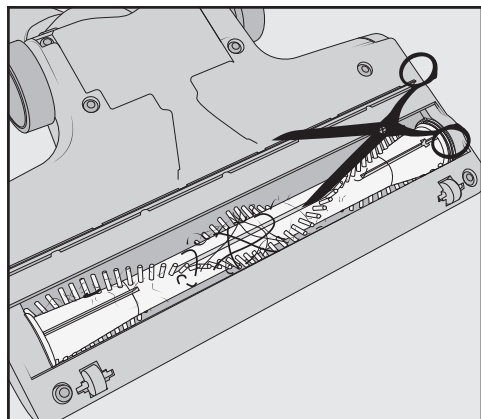

- 用剪刀剪掉纏繞在滾筒塵刷上的所有細線或頭髮。請沿著滾筒塵刷上的導軌剪開。

之後用吸塵機吸走剪掉的細線及頭髮。

如果小滾輪非常髒或被阻塞，可以將其取下以方便清潔。如要取下，使用平口螺絲刀。

取出電動吸頭的滾筒塵刷

您可以將滾筒塵刷從電動吸頭中取出，以清除頑固的污垢，並清潔電動吸頭的內部。

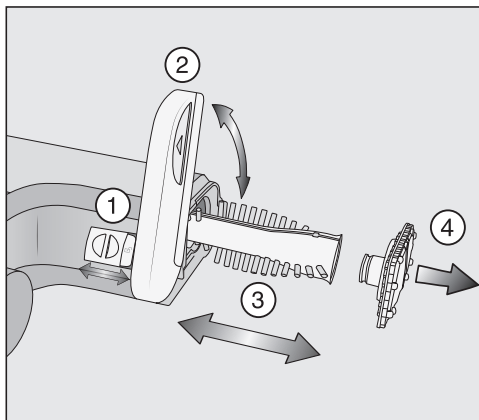

- 鬆開電動吸頭側面的遮蓋，露出  符號 ①。
- 儘量提起遮蓋 ②。
- 取出滾筒塵刷 ③。
- 如果您發現滾筒塵刷手柄嚴重變髒，可將其取下 ④。
- 清潔滾筒塵刷和滾筒塵刷手柄，以及清除電動吸頭內部的所有頑固污垢。
- 以相反順序重新組裝電動吸頭。

更換充電電池

需要原裝 Miele AP 01/AP 02/AP 03 鋰離子充電電池 (HX LA)。

請遵循以下各章節中有關充電電池的處理和棄置說明：“警告和安全”、“環保”和“安裝及連接”（“一般電池資料”）。

錯誤訊息



旋轉中的滾筒塵刷會構成受傷風險。

旋轉中的滾筒塵刷可能會讓您受傷。

在處理任何問題之前，請關閉吸塵機。使用 Comfort 手柄上的開/關按鈕來完成上述動作。

錯誤訊息以快速閃爍照明，在主機的電池充電狀態指示器上顯示。

問題	原因和糾正
頂部指示器快速閃爍	“未能識別 Comfort 手柄”錯誤 ■ 取出 Comfort 手柄並重新連接（請參閱“安裝及連接”-“連接 Comfort 手柄”）。 ■ 取出電池，等待 10 秒後重新放入。
中間指示器快速閃爍	“摩打過熱”錯誤 ■ 清空並清潔集塵箱、預過濾網和微塵濾網（請參閱“保養”）。 ■ 取出電池，等待 10 秒後重新放入。 ■ 等待約 30 分鐘再重新開啟吸塵機。
底部和頂部指示器快速閃爍	內部系統錯誤 ■ 取出電池，等待 10 秒，重新放入並充電。
底部和中間指示器快速閃爍	“電池過熱”或“未能識別電池”錯誤 ■ 等待約 30 分鐘再重新開啟吸塵機。 ■ 插入原裝 Miele AP 01/AP 02/AP 03 鋰離子充電池 (HX LA)。

排除故障

在日常操作過程中出現的許多機件失靈和故障問題，其實都可輕易解決。在許多情況下，您可以節省時間和金錢，因為您無需致電 Miele 客戶服務部。

您可在 www.miele.com/service 上找到可幫助您自行修復故障的資訊。

下表旨在幫助您找到機件失靈或故障的原因並加以解決。

 旋轉中的滾筒塵刷會構成受傷風險。

旋轉中的滾筒塵刷可能會讓您受傷。

在處理任何問題之前，請關閉吸塵機。使用 Comfort 手柄上的開/關按鈕來完成上述動作。

問題	原因和糾正
吸塵機總是傾倒。	您已將吸塵機的配置方式設置為主機位於頂部。 ■ 重新組裝吸塵機，將主機放置在底部（請參閱“安裝和連接”-“組裝吸塵機”）。
清潔性能欠佳。	集塵箱已滿。 ■ 清空和清潔集塵箱（請參閱“保養”）。 電動吸頭很髒/堵塞。 ■ 清潔電動吸頭（請參閱“保養”-“清潔電動吸頭”和“取出電動吸頭滾筒塵刷”）。
清潔性能降低。	微塵濾網/預過濾網很髒。 ■ 為微塵濾網運行臨時清潔功能（請參閱“保養”-“啟用 ComfortClean 功能”）。 ■ 徹底清潔兩個濾網（請參閱“保養”-“清潔預過濾網和微塵濾網”）。 微塵濾網磨損。 ■ 插入新微塵濾網（HX FSF-2）。
滾筒塵刷不轉動。	滾筒塵刷變髒。 ■ 清潔滾筒塵刷（請參閱“保養”-“清潔電動吸頭”和“取出電動吸頭滾筒塵刷”）。
在吸塵期間，運行噪音有所變化。	根據地板的類型和使用的滾筒塵刷，電動吸頭的功耗會自動設置為最佳水平。 ■ 噪音並不罕見 - 吸塵機運作正常。
電動吸頭自動關閉。	電動吸頭超載 - 這可能會在長毛絨地毯等表面上發生。 ■ 關閉吸塵機，然後以較低的吸力模式再開啟。使用 Comfort 手柄上的開/關按鈕來完成上述動作。

問題	原因和糾正
吸塵機開啟後並無啟動。	<p>沒有放入電池或電池放置不正確。</p> <ul style="list-style-type: none"> ■ 放入電池或檢查電池的位置（請參閱“安裝及連接”-“放入電池”）。
	<p>充電池未完全充滿電。</p> <ul style="list-style-type: none"> ■ 完全按照這些操作說明進行電池充電（請參閱“安裝及連接”-“一般電池資料”和“電池充電”）。
	<p>未放入原裝 Miele 電池。</p> <ul style="list-style-type: none"> ■ 插入原裝 Miele AP 01/AP 02/AP 03 鋰離子充電池 (HX LA)。
	<p>電池的首次充電未在主機中進行。</p> <ul style="list-style-type: none"> ■ 如要啟用電池，務必在主機中進行首次充電（請參閱“安裝與連接”-“一般電池資料”和“電池充電”）。
	<p>仍然與充電器連接。</p> <ul style="list-style-type: none"> ■ 將插頭從電池底部的充電插座中拔出。

服務

您可在 www.miele.com/service 上查找可幫助您自行糾正故障以及有關 Miele 備件的資訊。

故障時的聯絡方式

如果您無法自行解決故障，請聯絡 Miele 經銷商或 Miele 服務部。

Miele 服務的聯絡資訊載於本文件的最後部分。

請注意，出於培訓目的，電話可能被監控和記錄。而如果問題可以如本手冊所述解決，將為該上門服務收取費用。

保養

如欲瞭解您所在國家或地區的特定電器保養資訊，請聯絡 Miele。請參見本手冊結尾部分的聯絡詳情。

阿聯酋 (UAE) 的保養

電器保養自購買之日起 2 年有效。
在阿聯酋，有關特定國家/地區的保養條款和條件的詳情，請聯絡 Miele 客戶服務。請參見本手冊結尾部分的聯絡詳情。

清潔與護理

 旋轉中的滾筒塵刷會構成受傷風險。

旋轉中的滾筒塵刷可能會讓您受傷。在清潔之前，請始終關閉吸塵機。使用 Comfort 手柄上的開/關按鈕來完成上述動作。

吸塵機及配件

 電源電壓可導致觸電危險。
如果充電器受潮，可能會導致觸電。請勿讓充電器受潮。

按照“保養”一節集塵箱的特殊清潔說明進行操作。

可以使用適用於塑膠的市售清潔劑，清潔吸塵機和所有塑膠配件。

 不合適的清潔劑可導致損壞。
所有表面都有機會刮花。與不合適的清潔劑接觸會令所有表面改變或褪色。
請勿使用研磨劑、玻璃清潔劑、多用途清潔劑或油性護理產品。

可選配件

請遵從地板製造商的清潔和保養說明。

我們建議只使用包裝上有“ORIGINAL Miele”標誌的原裝 Miele 塵袋、濾網和配件。只有這樣才能保證您的吸塵機發揮最佳性能並獲得最佳清潔效果。

請注意，因使用了在包裝上沒有“ORIGINAL Miele”標誌的配件所造成的故障和損壞，不在吸塵機保養範圍之內。

購買配件

Miele 原裝配件可從 Miele 網上商店、Miele 客戶服務部或 Miele 經銷商處訂購。

原裝 Miele 配件的包裝上有“ORIGINAL Miele”標誌。



憑藉 3D4U，Miele 還提供免費配件供您的 3D 印表機下載（www.miele.com，服務，3D4U）。

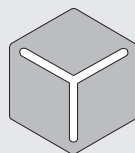

3 D 4 U

某些型號標準配備下列一個或多個附件。

手提式迷你電動吸頭 (HX-EC 10)

適合對汽車座椅和地毯樓梯進行徹底清潔

硬地板護理軟滾筒塵刷 (HX HC)

適合清潔精緻的硬地板

通用塵刷 (HX - UB)

用於輕柔地對書籍、書架或類似物品吸塵。

散熱器塵刷 (SHB 30)

用來刷除散熱器、窄長架子及罅隙上的灰塵。

床褥吸咀 (SMD 10)

用來清潔傢俱布料、床褥、墊子、窗簾、罩布等。

罅隙吸咀 300 毫米 (SFD 10)

加長罅隙吸咀，用來清潔狹縫、罅隙及角落。

罅隙吸咀 560 毫米 (SFD 20)

靈活的罅隙吸咀，用於清潔難以觸及部位。

伸縮靈活特大罅隙吸咀 (HX - CNXL)

靈活罅隙吸咀可以伸長 60 厘米，清潔難以到達的區域。

延長軟管 (HX - FSH 10)

可以將吸塵半徑增加最多 120 厘米。

額外 AP 01/AP 02/AP 03 電池 (HX LA)

使吸塵機的運作時間增加一倍

首次充電之前，請務必閱讀“安裝及連接” - “一般電池資料”中的資訊。

LS 03 充電器底座 (HX LS)

用於獨立於電器為額外電池充電，即當電器使用中仍可充電

首次充電之前，請務必閱讀“安裝及連接” - “一般電池資料”中的資訊。

微塵濾網 (HX FSF-2)

為了繼續達到最佳的清潔效果，約 3 年後便要更換新的標配安裝的微塵濾網（請參閱“清潔預過濾網和微塵濾網”）。

Contents

Warning and Safety instructions	4
Safety instructions and warnings for AP01/AP02/AP03 battery, LG01/LG02 charger, LS03 charger cradle (depending on the model)	8
Guide to the appliance	14
Caring for the environment	16
Installation and connection	18
Assembling the vacuum cleaner	18
Using the PowerUnit solo	18
Connecting the Comfort handle	19
Connecting the PowerUnit and the suction tube	19
Inserting the battery	20
Connecting the Electrobrush.....	21
General battery information.....	21
Charging the battery (without wall mounting).....	22
Charging the battery (with wall mounting).....	22
Battery charging state indicator (while charging)	25
Battery charging state indicator (while in use).....	25
Using the supplied accessories	26
Accessories holder for the suction tube.....	26
Multi Floor XXL Electrobrush.....	27
Hardfloor Care soft roller (HX HC)	27
Additional battery (HX LA)	28
Use	28
Switching on and off	28
Selecting the suction power level	29
Illuminating the work area	29
Self-standing function for short pauses in vacuuming.....	29
Maintenance	29
Purchasing accessories	30
Filter system	30
Activating the ComfortClean function	31
Emptying the dust container	31
Cleaning the pre-filter and fine dust filter	32
Cleaning the dust container	34
Cleaning the Electrobrush	35
Replacing the rechargeable battery	36
Error messages	37
Troubleshooting	38

Contents

Service	40
Contact in case of malfunction	40
Guarantee.....	40
Warranty in the UAE	40
Cleaning and care	40
Optional accessories	41
Purchasing accessories	41

Warning and Safety instructions

This vacuum cleaner conforms to current safety requirements. Inappropriate use can lead to personal injury and damage to property.

Please read the operating instructions before using the vacuum cleaner for the first time. They contain important information on the safety, use and maintenance of the vacuum cleaner. This will prevent both personal injury and damage to the appliance.

In accordance with standard IEC 60335-1, Miele expressly and strongly advises that you read and follow the instructions in the “Installation and connection” section as well as the safety instructions and warnings.

Miele cannot be held liable for injury or damage caused by non-compliance with these instructions.

Keep these operating instructions in a safe place and pass them on to any future owner.

Always disconnect the vacuum cleaner from the power supply when you have finished using it, before changing any accessories, as well as for maintenance work, cleaning and troubleshooting. Use the On/Off switch on the Comfort handle to do this.

Correct application

- ▶ This vacuum cleaner is intended for cleaning flooring in domestic households and similar residential environments. This vacuum cleaner is not suitable for use on construction sites.
- ▶ This vacuum cleaner is not intended for outdoor use.
- ▶ This vacuum cleaner can be used for all normal cleaning of carpets, rugs and robust hard flooring.
- ▶ This vacuum cleaner is intended for use at altitudes of up to 4000 m above sea level.

Warning and Safety instructions

- ▶ The vacuum cleaner must only be used to vacuum dry floor surfaces. Do not vacuum people or animals. Any other types of use, modifications or alterations are not permitted.
- ▶ The vacuum cleaner can only be used by people (including children) with reduced physical, sensory, or mental capabilities, or lack of experience or knowledge, if they are supervised whilst using it or have been shown how to use it in a safe way and understand and recognise the consequences of incorrect operation.

Safety with children

- ▶ Danger of suffocation. Packaging, e.g. plastic wrappings, must be kept out of the reach of babies and children. Whilst playing, children could become entangled in packaging or pull it over their head and suffocate.
- ▶ Children under 8 years of age must be kept away from the vacuum cleaner unless they are constantly supervised.
- ▶ Children aged 8 and older may only use the vacuum cleaner without supervision if they have been shown how to use it in a safe manner. Children must be able to understand and recognise the possible dangers caused by incorrect operation.
- ▶ Children must not be allowed to clean or maintain the vacuum cleaner unsupervised.
- ▶ Please supervise children in the vicinity of the vacuum cleaner and do not let them play with it.

Warning and Safety instructions

Technical safety

▶ The vacuum cleaner operates at 25.2 V.

It is classified as a class II  appliance and is constructed in protection class III.

This appliance is supplied by a safety extra-low voltage (SELV) power source where the voltage is low enough to protect users from the risk of electrical shock. A Class II  charger is used for supplying power to charge the vacuum cleaner.

▶ Compare the connection data on the data plate of the charger (voltage and frequency) with that of the mains electricity supply. This data must match exactly. Without modifications, the charger is suitable for 50 Hz and 60 Hz.

▶ The mains electrical plug must be fitted with an appropriate fuse.

▶ Check both the vacuum cleaner and all accessories supplied with it for any visible signs of damage before use. Do not use a damaged vacuum cleaner or damaged accessory.

▶ The Miele Multi Floor XXL Electrobrush and the Miele Electro Compact handheld brush (varies according to the model) are additional motor-driven devices designed specially for this Miele vacuum cleaner. For safety reasons, the vacuum cleaner must not be used with a different Miele Electrobrush/handheld brush or an Electrobrush/handheld brush produced by another manufacturer.

▶ Before and during use, make sure that no coarse dirt or debris is/gets trapped in the bottom of the Multi Floor XXL Electrobrush or in the bottom of the Electro Compact handheld brush (supplied depending on model).

▶ Store the vacuum cleaner and all accessories at an ambient temperature between 0 °C and 45 °C.

▶ While the vacuum cleaner is under warranty, repairs should only be undertaken by a Miele authorised service technician. Otherwise the warranty will be invalidated.

Warning and Safety instructions

▶ Repairs should only be carried out by a Miele authorised service technician. Repairs and other work by unqualified persons can cause considerable danger to users.

Correct use

▶ Do not use the vacuum cleaner without the dust container, pre-filter and fine dust filter fitted.

▶ Do not vacuum up anything which has been burning or is still glowing e.g. cigarettes, ashes or coal, whether glowing or apparently extinguished.

▶ Do not use the vacuum cleaner to vacuum up any water, liquid or damp dirt. Wait until any freshly cleaned or shampooed rugs or carpets are completely dry before attempting to vacuum.

▶ Do not use the vacuum cleaner to vacuum toner dust. Toner, such as that used in printers and photocopiers, can conduct electricity.

▶ Do not vacuum up any inflammable or combustible liquids or gases and do not vacuum in areas where such substances are stored.

▶ Never touch the Multi Floor XXL Electrobrush or Electro Compact handheld brush (varies according to the model) while it is rotating.

▶ Do not use the Multi Floor XXL Electrobrush or the Electro Compact handheld brush (varies according to the model) at head height.

▶ Do not vacuum at head height and do not let the suction get anywhere near a person's head.

Warning and Safety instructions

Safety instructions and warnings for AP01/AP02/AP03 battery, LG01/LG02 charger, LS03 charger cradle (depending on the model)

Safety with children

- ▶ People (including children) with reduced physical, sensory or mental capabilities, or lack of experience or knowledge, who are unable to use the LG01/LG02 charger or LS03 charger cradle safely may only use this vacuum cleaner if they are supervised whilst using it or have been shown how to use it in a safe way and understand and recognise the consequences of incorrect operation.
- ▶ Keep the AP01/AP02/AP03 battery out of the reach of children.
- ▶ Children must be kept away from the LG01/LG02 charger and the LS03 charger cradle unless they are constantly supervised.

Technical safety

- ▶ The AP01/AP02/AP03 battery, the LG01/LG02 charger and the LS03 charger cradle are designed for use with the Miele HS19 vacuum cleaner. For safety reasons, the vacuum cleaner must not be used with a battery, charger or charger cradle produced by another manufacturer.
- ▶ Only the LG01/**xx** or LG02/**xx** charger included or the LS03/**xx** charger cradle included or purchased as an optional accessory should be used to charge the AP01/AP02/AP03 battery. **xx** stands for 01, 02, 03, 04, 05, 06, 07 or 08; these numbers identify the version of your LG01/LG02 charger and your LS03 charger cradle.

Warning and Safety instructions

XX	LG01/LS03	LG02
01	AT, BE, BG, CH, CL, CZ, DE, DK, EE, ES, FI, FR, GR, HR, HU, IT, KZ, LT, LU, LV, NL, NO, PL, PT, RO, RS, RU, SE, SI, SK, TR, UA, ZA	AT, BE, BG, CH, CL, CZ, DE, DK, EE, ES, FI, FR, GR, HR, HU, IT, KZ, LT, LU, LV, NL, NO, PL, PT, RO, RS, RU, SE, SI, SK, TR, UA, ZA
02	AE, HK, IE, MY, SG, UK	AE, HK, IE, MY, SG
03	BR, CA, MX, US	BR, CA, JP, MX, US
04	AU, NZ	AU, NZ
05	CN	CN
06	KR	KR
07	JP	UK
08	IN	

▶ If you are using a mains plug adapter, make sure that it is approved for continuous operation.

▶ Temporary or permanent operation on an autonomous power supply system or a power supply system that is not synchronised with the mains power supply (e.g. island networks, back-up systems) is possible. A prerequisite for operation is that the power supply system complies with the specifications of EN 50160 or an equivalent standard.

The function and operation of the protective measures provided in the domestic electrical installation and in this Miele product must also be maintained in isolated operation or in operation that is not synchronised with the mains power supply, or these measures must be replaced by equivalent measures in the installation. As described, for example, in the current version of BS OHSAS 18001–2 ISO 45001.

▶ Charge and use the AP01/AP02/AP03 battery at an ambient temperature between 0 °C and 45 °C.

Using the AP01/AP02/AP03 battery outside of this ambient temperature range will limit its performance.

Warning and Safety instructions

- ▶ Stop using the AP01/AP02/AP03 battery immediately if you notice an unusual smell from it, if liquid is leaking from it, if it is significantly overheating or if it is discoloured or deformed. Dispose of the AP01/AP02/AP03 battery immediately (see safety notice “Disposing of the AP01/AP02/AP03 battery” at the end of this chapter as well as “Caring for the environment – Disposing of old batteries”).
- ▶ Batteries will deplete over time. They can then leak corrosive fluids. Avoid contact with the eyes and skin. In the event of contact, rinse thoroughly with water and seek medical advice.
- ▶ The AP01/AP02/AP03 lithium-ion battery is subject to the dangerous goods legislation. The user is permitted to transport the AP01/AP02/AP03 battery by road without having to observe any further requirements. Please contact the Miele Customer Service Department before sending the AP01/AP02/AP03 battery. Only send AP01/AP02/AP03 batteries that are undamaged and have been fully run down. Insulate the metal contacts with adhesive tape to prevent short circuits. Pack the AP01/AP02/AP03 battery in such a way that it is not able to move around inside the packaging.

Warning and Safety instructions

Correct use

- ▶ Do not drop or throw the AP01/AP02/AP03 battery. For safety reasons, do not continue to use an AP01/AP02/AP03 battery which has been damaged.
- ▶ Keep the AP01/AP02/AP03 battery away from naked flames or other heat sources. Do not heat the AP01/AP02/AP03 battery. Do not expose the rechargeable battery to direct sunlight.
- ▶ Do not dismantle the AP01/AP02/AP03 battery.
- ▶ Do not cause a short circuit by bridging the contacts of the AP01/AP02/AP03 battery, either unintentionally or deliberately.
- ▶ Do not allow the AP01/AP02/AP03 battery to come into contact with liquids.
- ▶ Disposing of the AP01/AP02/AP03 battery: remove the AP01/AP02/AP03 battery from the vacuum cleaner. Insulate the metal contacts with adhesive tape to prevent short circuits. Dispose of the AP01/AP02/AP03 battery in a municipal recycling facility. Do not dispose of the AP01/AP02/AP03 battery with your household waste.

Warning and Safety instructions

Cleaning

- ▶ Do not immerse the vacuum cleaner or any accessories supplied with it in water.
- ▶ The Multi Floor XXL Electrobrush and the Electro Compact handheld brush (depending on the model), the PowerUnit, the suction tube and the Comfort handle contain electrical wires. The plug connectors must not come into contact with water. Danger of electric shock. They should only be cleaned with a dry cloth.
- ▶ Clean the vacuum cleaner and accessories only with a dry or slightly damp cloth when disconnected from the power supply.
Exception:
 - Dust container: empty the dust container and remove the pre-filter. Clean the dust container using water and mild washing-up liquid only. Then dry the dust container carefully. Replace the pre-filter in the dust container.

Accessories and spare parts

- ▶ Only use genuine accessories with the “ORIGINAL Miele” logo on the packaging. The manufacturer cannot otherwise guarantee the safety of the product.
- ▶ Miele can only guarantee the safety of the appliance when genuine Miele replacement parts are used. Faulty components must only be replaced with genuine Miele replacement parts.

Transport

- ▶ The packaging material protects the vacuum cleaner from transport damage. We recommend you keep the packaging for transport purposes.

Guide to the appliance

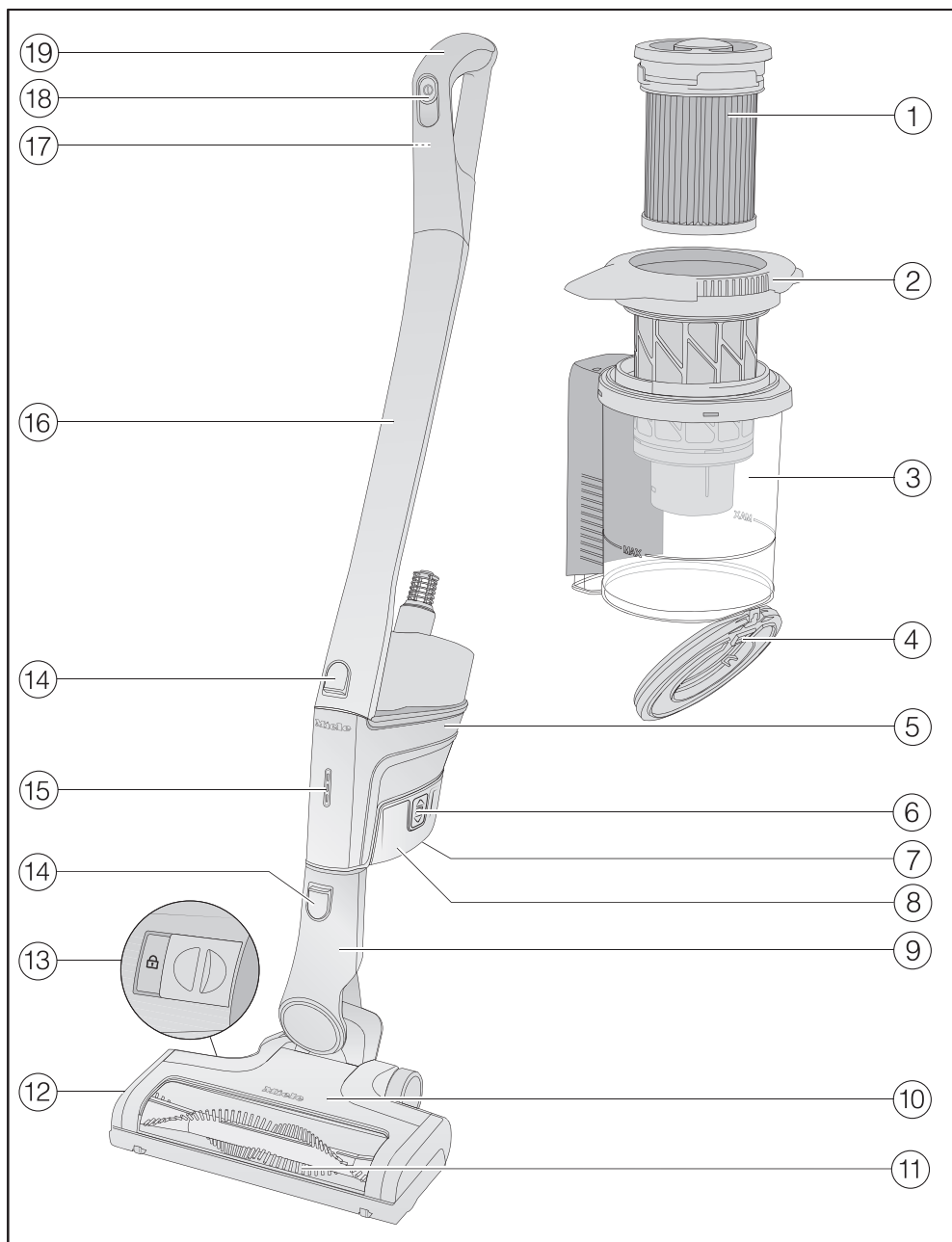

- ① Fine dust filter (HX FSF-2)
- ② Pre-filter
- ③ Dust container
- ④ Dust container flap
- ⑤ PowerUnit with a connection at the bottom for the battery, a connector at the bottom for the suction tube and Electrobrush, and a connector at the top for the suction tube and Comfort handle
- ⑥ Release buttons for battery (on both sides of the battery)
- ⑦ Charging socket (at the bottom of the battery)
- ⑧ AP01/AP02/AP03 lithium-ion battery (HX LA)
- ⑨ Electrobrush connector
- ⑩ Multi Floor XXL Electrobrush (some models feature BrilliantLight lighting)
- ⑪ Removable roller brush
- ⑫ Flap
- ⑬ Release catch for opening the Electrobrush
- ⑭ Release buttons
- ⑮ Battery charging state indicator
- ⑯ Suction tube
- ⑰ Release button for Comfort handle (on the back)
- ⑱ On/Off switch with suction power selector
- ⑲ Comfort handle

Caring for the environment

Disposing of the packaging material

The packaging material is used for handling and protects the appliance from transport damage. The packaging material used is selected from materials which are environmentally friendly for disposal and can generally be recycled.

Recycling the packaging material reduces the use of raw materials. Use material-specific collection points for valuable materials and take advantage of return options.

We recommend you keep the packaging material for transport purposes.

Disposing of your old appliance

Before disposing of your old appliance, remove the fine dust filter and dispose of it with your household waste.

Electrical and electronic appliances contain many valuable materials. They also contain certain materials, compounds and components which were essential for their correct functioning and safety. These could be hazardous to human health and to the environment if disposed of with household waste or if handled incorrectly. Please do not, therefore, dispose of your old appliance with household waste.



Instead, please make use of officially designated collection and disposal points to dispose of and recycle electrical and electronic appliances in your local community, with your dealer or with Miele, free of charge. By law, you are solely responsible for deleting any personal data from the old appliance prior to disposal. You are legally obliged to remove any old batteries which are not securely enclosed by the appliance and to remove any lamps without destroying them, where this is possible. These must be taken to a suitable collection point where they can be handed in free of charge. Please ensure that your old appliance poses no risk to children while being stored for disposal.

Disposing of old batteries

In many cases, electrical and electronic appliances contain batteries which must not be disposed of with household waste after use. You are legally obliged to remove any old batteries which are not securely enclosed by the appliance and take them to a suitable collection point (e.g. retailer) where they can be handed in free of charge. Insulate the metal contacts with adhesive tape to prevent short circuits. Batteries may contain substances which can be hazardous to human health and the environment.

The labelling on the battery will provide further information. For example, batteries containing lithium are marked “Li-ion”. The bin symbol with a cross through it means that the batteries must not be disposed of in household waste. We are also required to inform you that a bin with a cross through it which also has one or more chemical symbols on it indicates that the battery contains lead (Pb), cadmium (Cd) and/or mercury (Hg).



Old batteries contain valuable raw materials which can be recycled. Disposing of batteries separately makes them easier to handle and recycle.

Installation and connection

Assembling the vacuum cleaner

You can assemble the vacuum cleaner in 2 different ways.

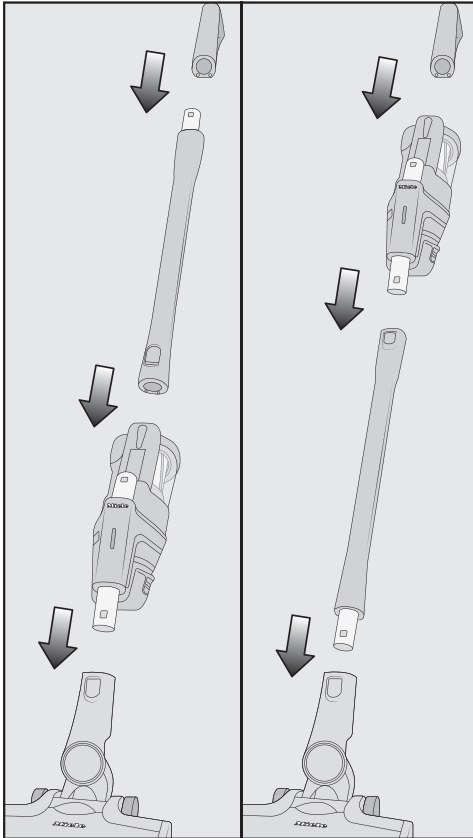

- You can place the suction tube either above or below the PowerUnit.

Take care to assemble the vacuum cleaner exactly as shown in the diagram.

The advantages of placing the **PowerUnit at the bottom** of the vacuum cleaner are as follows:

- Secure self-standing function possible

(see “Use – Self-standing function for short pauses in vacuuming”)

- Ergonomic (reduced strain on the wrist)
- Convenient cleaning of large surfaces

The advantages of placing the **PowerUnit at the top** of the vacuum cleaner are as follows:

- Convenient cleaning underneath furniture
- PowerUnit can be removed quickly

Using the PowerUnit solo

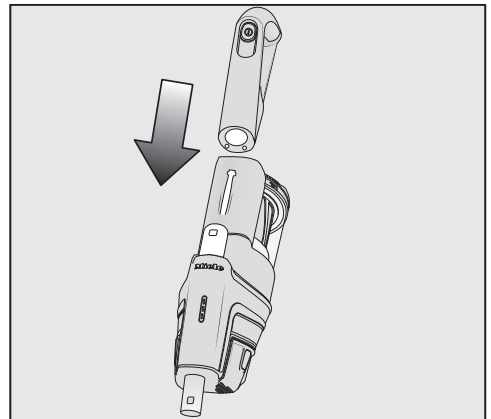

The PowerUnit can be used on its own without the suction tube and electrobrush as a quick way of vacuuming up crumbs and fluff in specific areas.

Tip: This configuration is particularly suitable when using the three-piece accessory set (see “Using the supplied accessories”).

Connecting the Comfort handle

Depending on how you decide to configure your vacuum cleaner, you can connect the Comfort handle to either the suction tube or the PowerUnit.

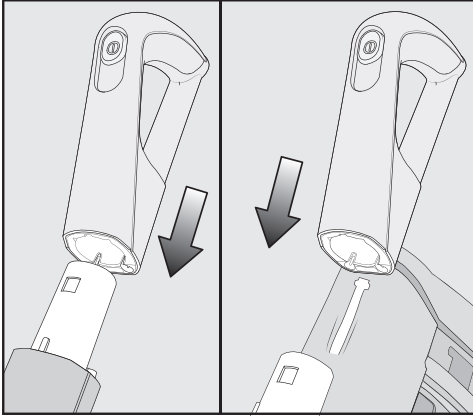

- Push the Comfort handle down onto the suction tube connector from above until it audibly clicks into place (left image detail).
- Slide the Comfort handle along the guide line on the dust container handle and down onto the PowerUnit connector from above until it audibly clicks into place (right image detail).
- Switch off the vacuum cleaner using the On/Off switch on the front of the Comfort handle if you want to separate the sections.

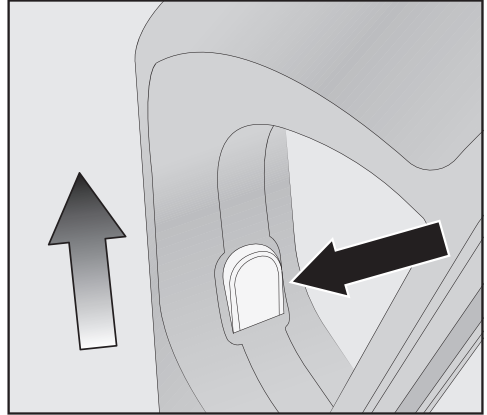

- Press the release button and remove the Comfort handle by pulling it upwards.

Connecting the PowerUnit and the suction tube

Depending on how you decide to configure your vacuum cleaner, the suction tube is located either above or below the PowerUnit.

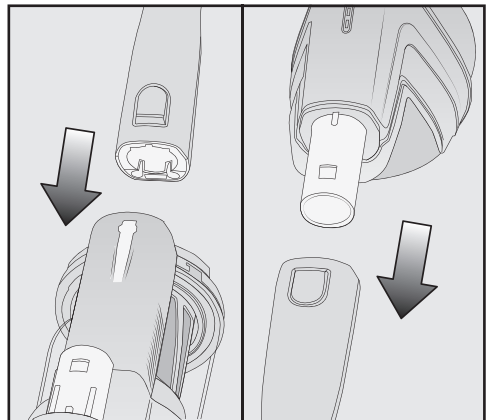

- Slide the suction tube along the guide line on the dust container handle and down onto the PowerUnit connector from above until it audibly clicks into place (left image detail).

- Push the PowerUnit connector into the suction tube from above until it audibly clicks into place (right image detail).

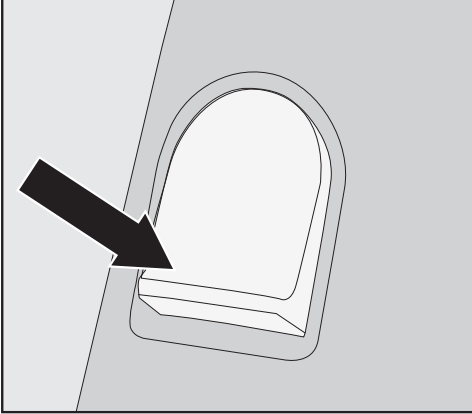

- Press the release catch to separate the individual sections from each other.

Inserting the battery

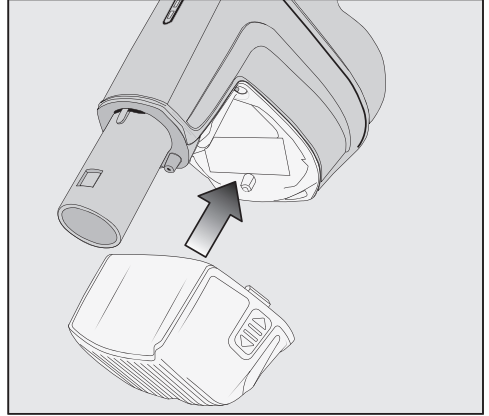

- Push the battery along the guide lines until it audibly clicks into place in the PowerUnit.

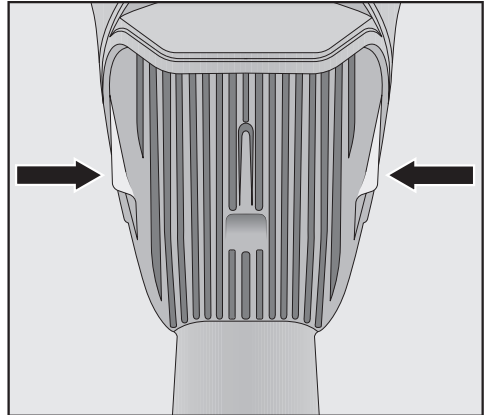

- If you want to separate the sections again, press both release catches at the side of the battery to remove the battery.

Connecting the Electrobrush

Depending on how you decide to configure your vacuum cleaner, you can connect either the PowerUnit connector or the suction tube connector to the Electrobrush.

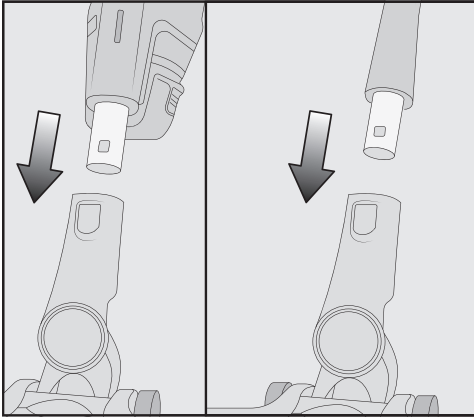

- Push the connector into the Electrobrush from above until it audibly clicks into place.

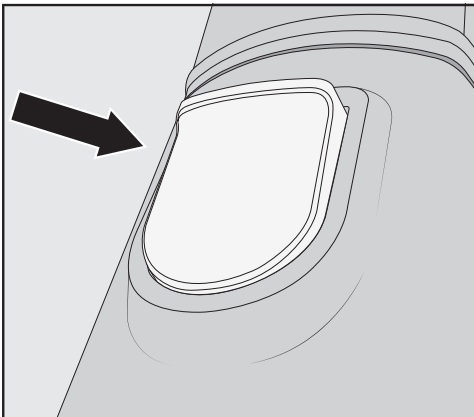

- To separate the individual sections from each other, press the release catch on the Electrobrush and pull the connector out of the Electrobrush.

General battery information

The rechargeable battery is supplied not fully charged.

Charge the battery completely before using it for the first time. Allow approximately 4 hours for this.

To activate the battery, it is essential to place it in the PowerUnit when charging it for the first time.

Once the battery is fully charged, the battery charging state indicator on the PowerUnit switches off to conserve energy.

The maximum charging capacity is only achieved once the battery has been charged and run down five times.

A full charge provides enough power for 14 minutes if the vacuum cleaner is used at the maximum power level in its fully assembled state.

However, if you use the PowerUnit solo and select the minimum power level, you can vacuum for up to 60 minutes at a time.

Charging the battery (without wall mounting)

You can store the vacuum cleaner upright and charge the battery directly.

Before charging the battery for the first time, you must read the information in “Installation and connection – General battery information”.

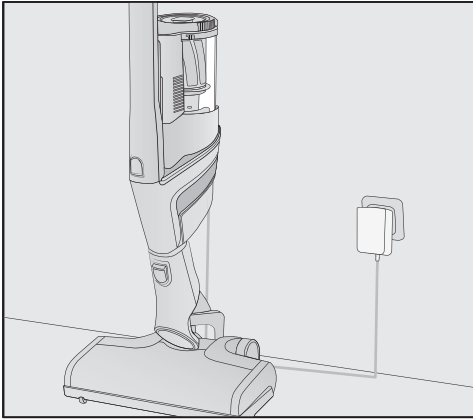

- Connect the PowerUnit to the Electrobrush to provide a secure base for the vacuum cleaner.
- Swing the vacuum cleaner forwards until the Electrobrush connector audibly clicks into place.
- Plug the supplied charging cable into the charging socket on the bottom of the battery.
- Plug the charger into a power socket.

The charging process will start.

You can read more about this in “Battery charging state indicator (while charging)”.

Charging the battery (with wall mounting)

You can store the vacuum cleaner in the included wall bracket and charge the battery at the same time.

Before charging the battery for the first time, you must read the information in “Installation and connection” – “General battery information”.

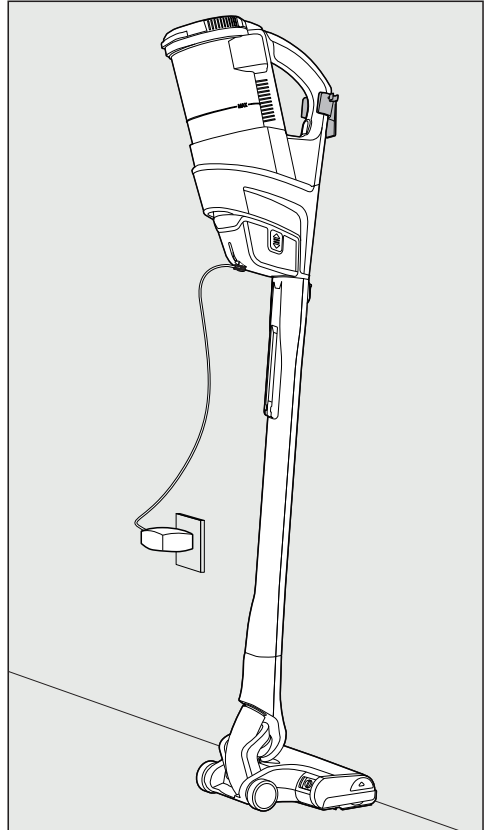

You will need a suitable location near a free power socket for mounting the appliance on the wall.

You can screw or stick the included wall bracket to the wall.

Screwing the wall bracket to the wall

The included screw bag contains 2 plugs and 2 T20 TORX screws. You will also need a battery-operated screwdriver or a drill (with a drilling diameter of 6 mm).

Select a distance of 104 cm between the bottom edge of the wall bracket and the floor.

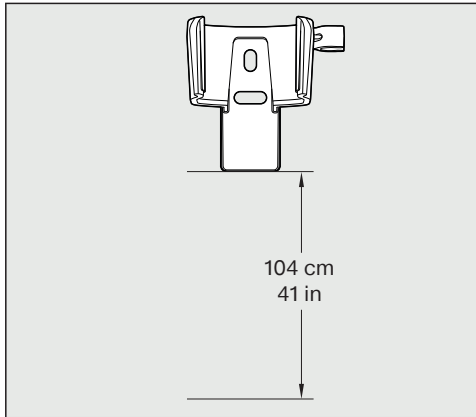

Be careful not to damage any cables laid in the wall.

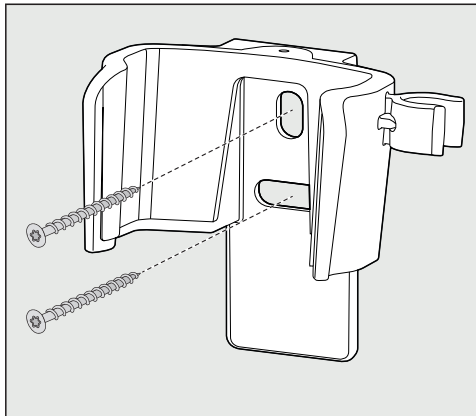

■ Attach the wall bracket to the wall.

Sticking the wall bracket to the wall

The bag of accessories included with the product contains an adhesive strip.

Select a distance of 104 cm between the bottom edge of the wall bracket and the floor.

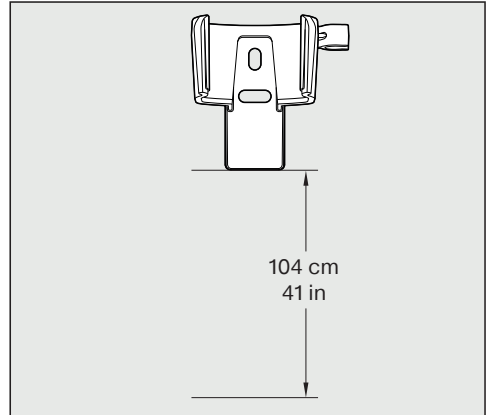

- Clean the surface of the wall with a soft, dust-free cloth.
- Remove one of the two protective films from the adhesive strip.
- With the tab at the bottom, carefully stick the adhesive strip to the back of the wall bracket.
- Press down hard and evenly on the adhesive strip for at least 5 seconds.

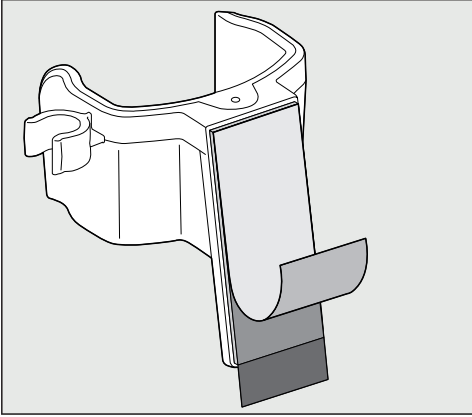

- Pull the second protective film up and off the adhesive strip and stick the wall bracket to the wall.
- Press down hard and evenly on the wall bracket for at least 5 seconds.
- To remove the wall bracket from the wall, pull the black tab on the adhesive strip down slowly parallel to the wall.

Charging the battery in the wall bracket

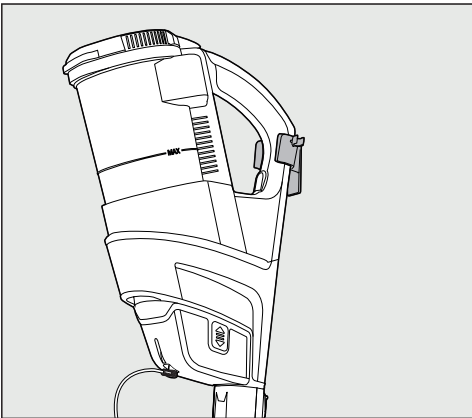

- Slide the Comfort handle of the fully assembled vacuum cleaner into the wall bracket.

- Plug the charging plug of the supplied charging cable into the charging socket on the bottom of the battery.
- Plug the charger into the power socket.

The charging process will start.

When you want to remove the vacuum cleaner, you can store the charging plug in the cable holder on the wall bracket.

- Pull the charging plug out of the charging socket on the battery.

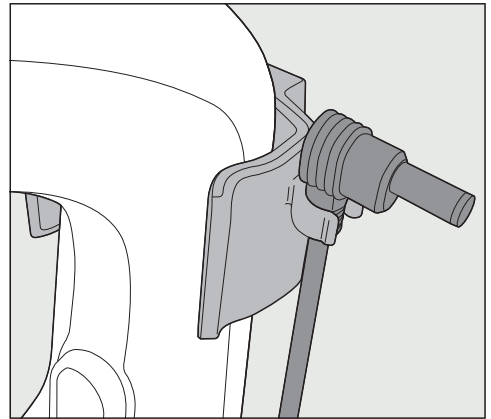

- Plug the charging plug into the cable holder on the wall bracket.

Battery charging state indicator (while charging)

The battery charging state is displayed on the PowerUnit.

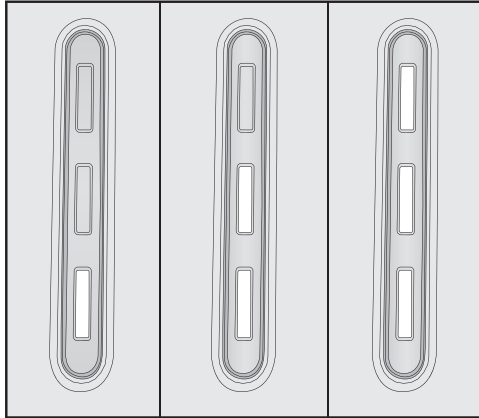

If the battery has not been used for a long time and has run down, it will go into safe mode. As a result, the battery charging state indicator will only respond after approximately 30–60 minutes when charging in the PowerUnit.

Battery charging state indicator (while in use)

The battery charging state is displayed on the PowerUnit.

Charging capacity	Display
Approx. 100–70 %	Top, middle and bottom lights are lit up
Approx. 69–35 %	Middle and bottom lights are lit up
Approx. 34–15 %	Bottom light is lit up
Approx. 14–0 %	Bottom light flashes slowly

We recommend allowing the battery to run down completely before recharging it. In this way, you will benefit from the battery's full capacity.

Charging capacity	Display
Approx. 0–34 %	Bottom light flashes slowly
Approx. 35–69 %	Bottom light is lit up; middle light flashes slowly
Approx. 70–90 %	Bottom and middle lights are lit up; top light flashes slowly
Approx. 91–99 %	Bottom, middle and top lights are lit up
100 %	Switches off

Once the battery is fully charged, the battery charging state indicator switches off to conserve energy.

Using the supplied accessories

Miele offers a range of suitable accessories for many special applications (see “Optional accessories”).

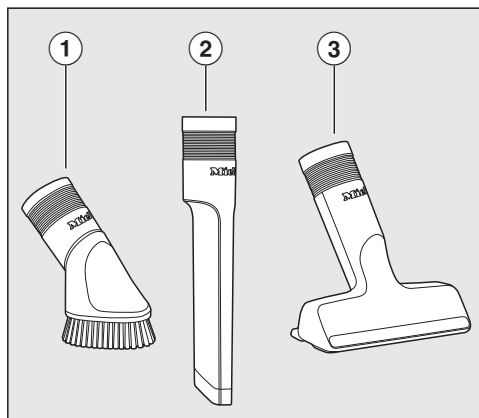

- ① **Dusting brush**
Accessory for vacuuming skirting boards, carved furniture or ornaments.
- ② **Crevice nozzle**
Accessory for cleaning in folds, crevices or corners.
- ③ **Upholstery nozzle**
Accessory for cleaning upholstery, mattresses and cushions.

Accessories holder for the suction tube

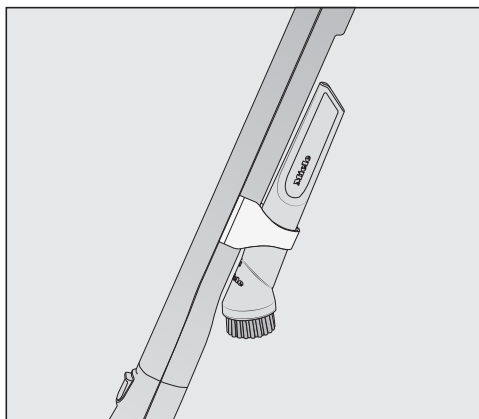

This accessories holder allows you to carry around 2 accessories from the three-piece accessory set while you vacuum.

Multi Floor XXL Electrobrush

Follow the flooring manufacturer's cleaning and care instructions.

 **Damage caused by trapped material.**

Risk of the flooring getting scratched.

Make sure that there is no coarse dirt or debris trapped in the bottom of the Electrobrush, e.g. shards or stones.

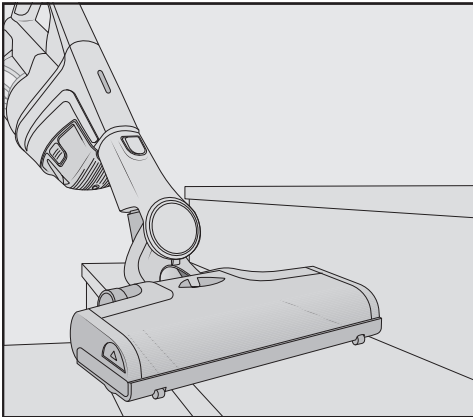

The Electrobrush can be used for daily cleaning of carpets, rugs and hard floors.

Tip: The suction tube is not a convenient option for cleaning carpeted stairs.

Tip: If you ever need to vacuum up substantial amounts of coarse dirt or debris, use the PowerUnit solo (see “Installation and connection – Using the PowerUnit solo”).

Hardfloor Care soft roller (HX HC)

(depending on model)

Follow the flooring manufacturer's cleaning and care instructions.

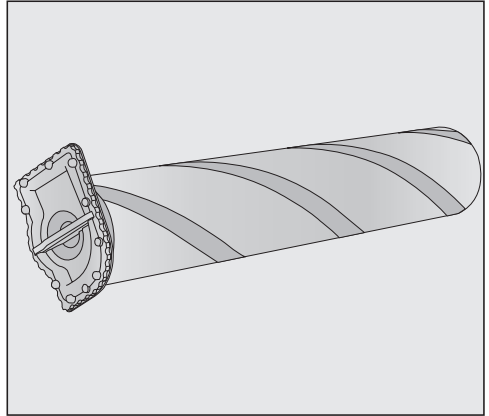

When fitted with the Hardfloor Care soft brush, the Electrobrush can be used to clean delicate hard floors.

Insert the Hardfloor Care soft brush into the Electrobrush instead of the roller brush fitted as standard.

When you use the Hardfloor Care soft roller, the Electrobrush power consumption is automatically set to the optimum level – this can lead to a change in the operating noise.

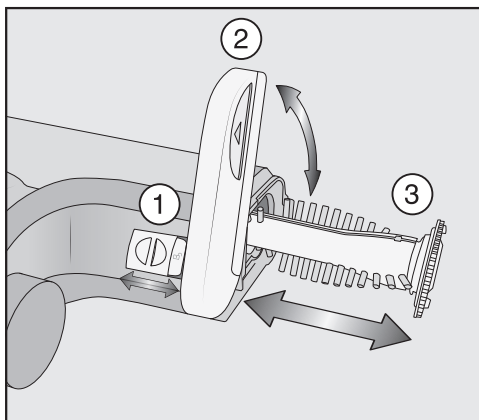

- Unlock the cover on the side of the Electrobrush so that the □ symbol becomes visible ①.
- Lift the cover up as far as it will go ②.
- Remove the roller brush that has been fitted as standard ③.
- Insert the Hardfloor Care roller brush.
- Close and lock the cover.

Additional battery (HX LA)

(depending on model)

Using the additional battery doubles the amount of time the vacuum cleaner can be used for.

Before charging for the first time, you must read the information in “Installation and connection – General battery information”.

Use

Switching on and off

- If you have charged the battery in the wall bracket, take the vacuum cleaner out of the wall bracket.
- If you have charged the battery directly, unplug the charger from the charging socket on the bottom of the battery.

For the best possible cleaning results, always activate the ComfortClean function before switching on the vacuum cleaner (see “Maintenance – Activating the ComfortClean function”).

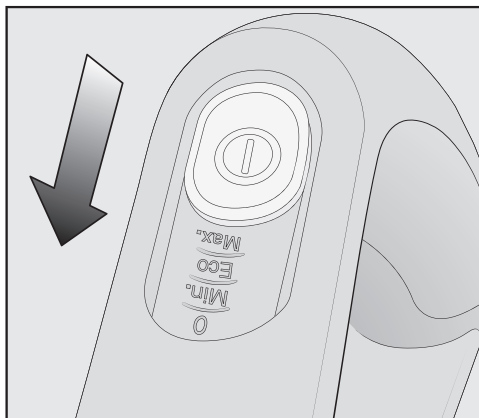

- Press the On/Off switch on the Comfort handle ①.

Selecting the suction power level

The suction power level can be adjusted for the specific situation. Reducing the suction power reduces the amount of effort required to manoeuvre the Electrobrush.

There are 3 power levels to choose from on the Comfort handle:

Min.	Lowest power level for light soiling
Eco	Medium power level for normal soiling
Max.	Highest power level for heavy soiling

The floor covering detection function is activated at every power level. The Electrobrush power consumption is automatically set to the optimum level based on the type of flooring and roller brush used – this can lead to a change in the operating noise.

Illuminating the work area

(depending on model)

The Electrobrush on your vacuum cleaner is equipped with BrilliantLight to illuminate the work area.

Self-standing function for short pauses in vacuuming

(For safety reasons, this function can only be used when the PowerUnit is fitted at the bottom of the vacuum cleaner)

If you are vacuuming with the PowerUnit fitted at the bottom of the vacuum cleaner, you can easily interrupt operation while the appliance is switched on.

- Swing the vacuum cleaner forwards until the Electrobrush connector audibly clicks into place.

The vacuum cleaner stays securely upright, the Electrobrush switches itself off and the battery is conserved. If you then unlock the connector on the Electrobrush, the Electrobrush will switch on again.

Maintenance

 Risk of injury caused by rotating roller brush.

You can injure yourself on the rotating roller brush.

Switch the vacuum cleaner off before doing any maintenance work. Use the On/Off switch on the Comfort handle to do this.

We recommend using only genuine Miele accessories bearing the “ORIGINAL Miele” logo on the packaging. Only these will guarantee the optimum suction power of your vacuum cleaner and the best possible cleaning results.

Please note that faults and damage caused by use of accessories which do not bear the “ORIGINAL Miele” logo on the packaging are not covered by the vacuum cleaner warranty.

Purchasing accessories

Original Miele accessories are available from the Miele webshop, the Miele Customer Service Department and from your Miele dealer.

Original Miele accessories are identified by the "ORIGINAL Miele" logo on the packaging.



With 3D4U, Miele also offers free accessories to download for your 3D printer (www.miele.com, Service, 3D4U).



3 D 4 U

Filter system

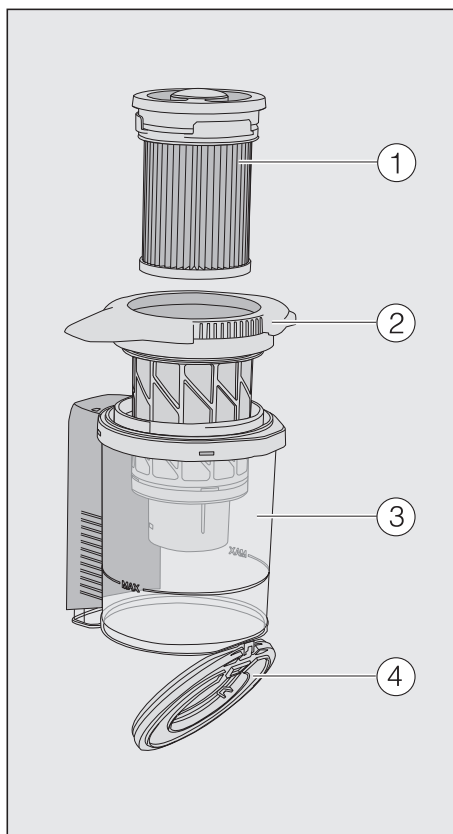

- ① Fine dust filter (HX FSF-2)
- ② Pre-filter
- ③ Dust container
- ④ Dust container flap

Activating the ComfortClean function

Always run the interim cleaning function for the fine dust filter before emptying the dust container. You should also run it whenever the suction power begins to drop.

This enables the vacuum cleaner to achieve the very best cleaning performance again straight away.

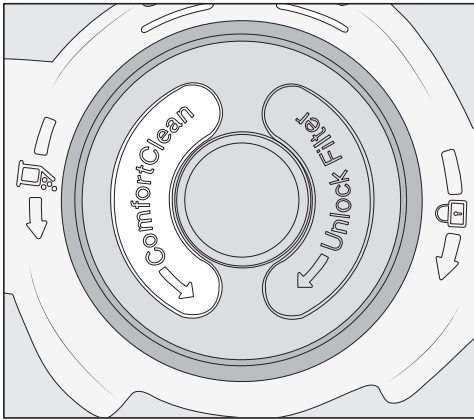

- The fine dust filter is located in the lid of the dust container. Twist it anti-clockwise by 3 180° turns. Use the recesses to help you.

You will hear an operating noise, which is a normal part of how the ComfortClean function works.

Emptying the dust container

Empty the dust container at the latest when the dust has reached the **MAX** marking on the dust container.

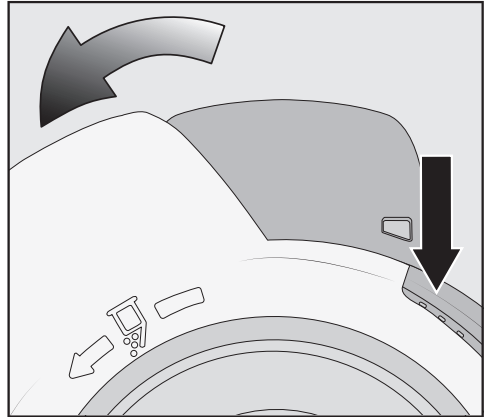

- Turn the lid of the dust container in the direction of the arrow as far as the first stop. Use the grey gripping surfaces to help you do this.

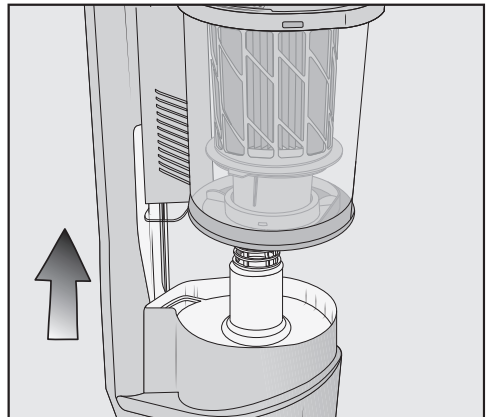

- Lift the dust container upwards to remove it.

Provided that no prohibited substances are present, the contents of the dust container can be disposed of with normal household waste.

- Hold the dust container close to the bin to prevent dust from billowing out.

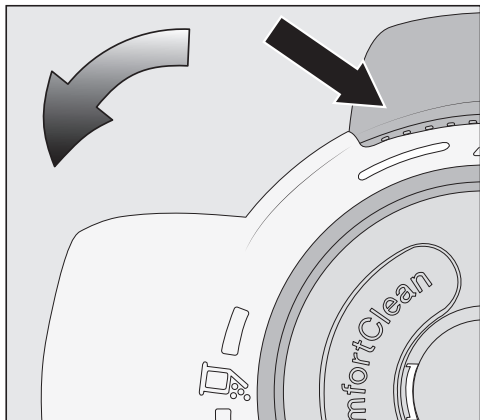

- Turn the lid of the dust container in the direction of the arrow as far as the next stop. Use the grey gripping surfaces to help you do this.

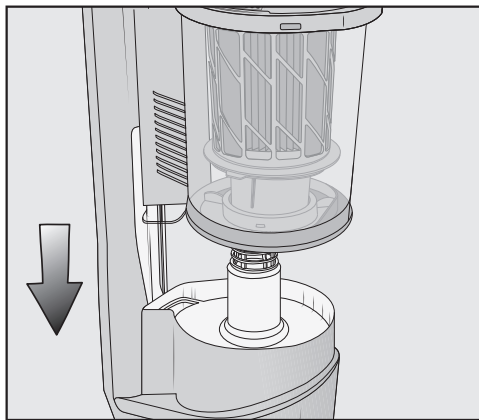

- Slide the dust container handle along the guide line and down onto the PowerUnit connector from above until the dust container audibly clicks into place.

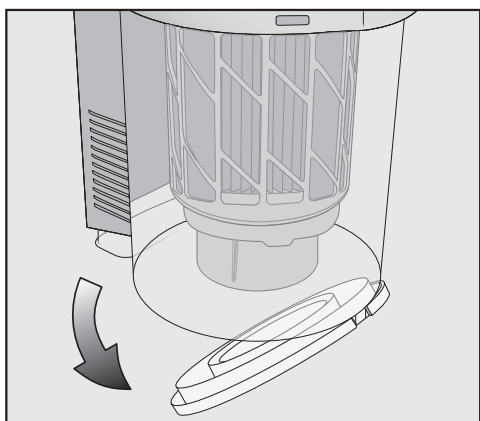

The dust container flap will open and the dust will fall out.

Cleaning the pre-filter and fine dust filter

Clean both filters thoroughly at least once every 3 months.

When cleaning them, it is essential to follow the steps in the order described.

- Remove the dust container.
- Empty the dust container over a bin.

If chunks of dust, hair or coarse debris do not fall out, remove the pre-filter by pulling it upwards (see “Cleaning the pre-filter and fine dust filter” below).

- Turn the lid of the dust container back to its original position.
- Close the dust container flap, making sure it clicks into place.

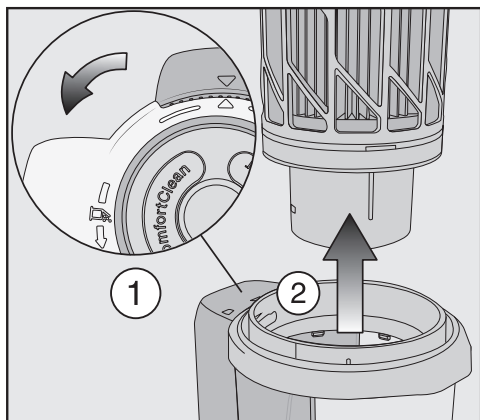

- Turn the lid of the dust container beyond the stop until the arrow tips are aligned at the top ①.
- Remove the pre-filter by pulling it upwards ②.

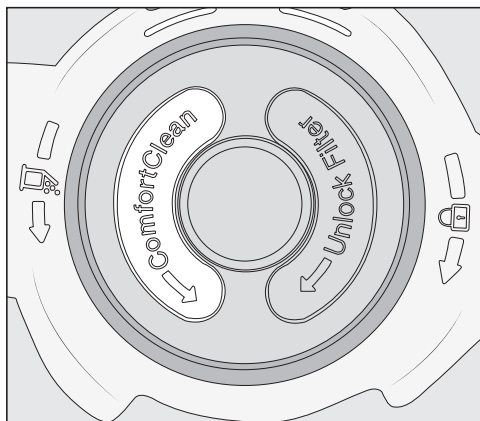

- Twist the fine dust filter anti-clockwise by 10 180° turns. Use the recesses to help you.

You will hear an operating noise, which is a normal part of how the ComfortClean function works.

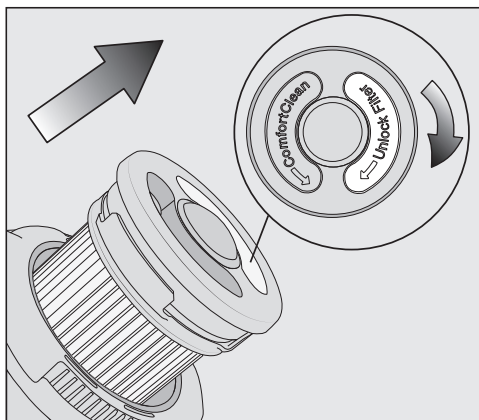

- Twist the fine dust filter clockwise. Use the recesses to help you.
- Remove the fine dust filter.

⚠ Risk of damage caused by incorrect cleaning.
 The fine dust filter can become damaged and be less effective as a result.
 Do not clean the fine dust filter with water and avoid cleaning the inside.
 Do not use pointed or sharp-edged objects to clean the filter. Do not brush the fine dust filter.

- Hold the fine dust filter over a bin.
- Empty the fine dust filter by carefully tapping the rubberised lower edge.
- Turn the fine dust filter slightly while you do this to free the dirt from all of the crevices.

 Risk of damage caused by incorrect cleaning.

The pre-filter can become damaged and be less effective as a result.

Do not clean the pre-filter with water.
Do not use pointed or sharp-edged objects to clean the filter.

- Clean the pre-filter with the dusting brush supplied or with a dry cloth.
- After cleaning the fine dust filter and pre-filter, reinsert the former into the latter by pressing the round cap on top of the fine dust filter down as far as it will go.

To continue achieving the best possible cleaning results, replace the fine dust filter (HX FSF-2) with a new one after approx. 3 years.

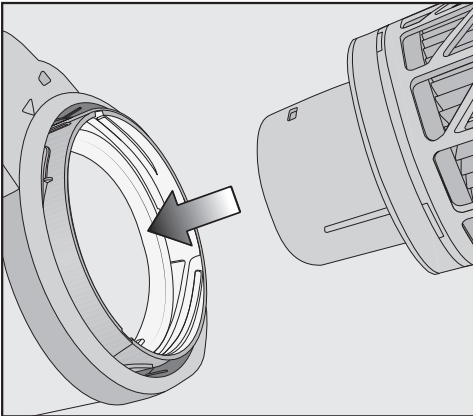

- Reinsert the pre-filter in the dust container.

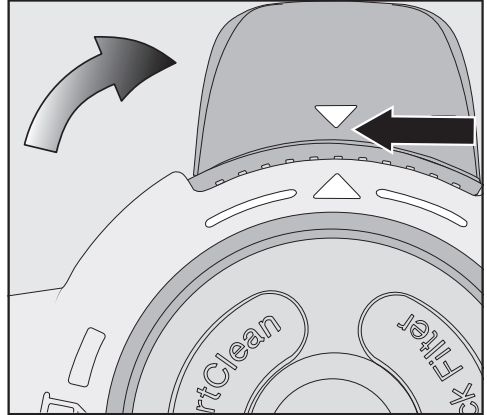

- To do this, line up the guides (arrows) and turn the pre-filter back to its original position.
- Close the dust container flap, making sure it clicks into place.
- Reattach the dust container to the PowerUnit connector.

Cleaning the dust container

Clean the dust container as required.

- Remove the dust container.
- Empty the dust container over a bin and lift the pre-filter upwards to remove it.
- Clean the dust container using water and mild washing-up liquid.
- Dry the dust container thoroughly.
- Reinsert the pre-filter in the dust container and turn the pre-filter back to its original position.
- Reattach the dust container to the PowerUnit connector.

Cleaning the Electrobrush

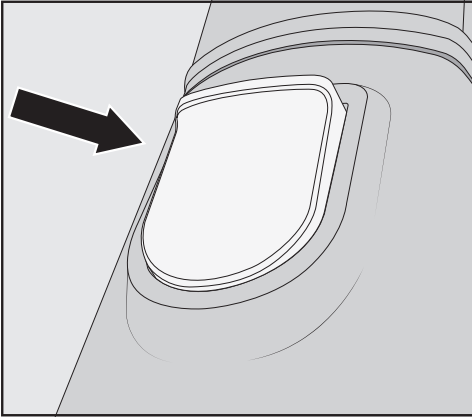

- Disconnect the Electrobrush from the vacuum cleaner.
- Place the Electrobrush upside down on a level, clean surface.

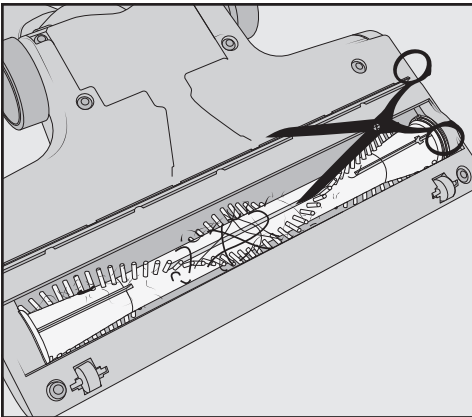

- Cut any threads or hairs that have wound themselves around the roller brush with a pair of scissors. To guide the scissors, move along the guide track on the roller brush.

Then run the vacuum cleaner to vacuum up the cut threads and hairs.

If the small running wheels are very heavily soiled or blocked, you can remove them for easier cleaning. To remove them, use a flat-head screwdriver.

Removing the roller brush from the Electrobrush

You can take the roller brush out of the Electrobrush in order to remove stubborn soiling and clean the inside of the Electrobrush.

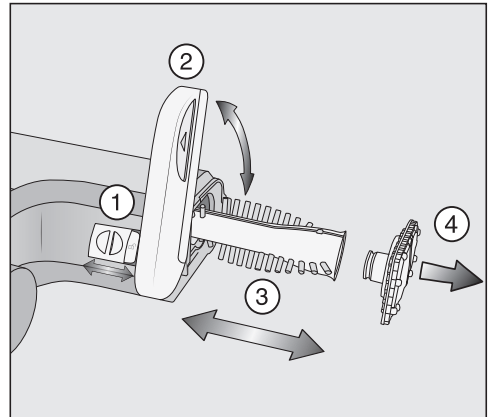

- Unlock the cover on the side of the Electrobrush so that the  symbol becomes visible ①.
- Lift the cover up as far as it will go ②.
- Remove the roller brush ③.
- Remove the roller brush handle if you identify heavy soiling there ④.
- Clean the roller brush and the roller brush handle, and remove any stubborn soiling inside the Electrobrush.
- Reassemble the Electrobrush in reverse order.

Replacing the rechargeable battery

An original Miele AP01/AP02/AP03 lithium-ion rechargeable battery (HX LA) is required.

Follow the instructions regarding the handling and disposal of rechargeable batteries found in the following sections: “Warning and safety”, “Caring for the environment” and “Installation and connection - General battery information”).

Error messages



Risk of injury caused by rotating roller brush.

You can injure yourself on the rotating roller brush.

Switch the vacuum cleaner off before dealing with any problems. Use the On/Off switch on the Comfort handle to do this.

Error messages are displayed with a quick flashing light on the battery charging state indicator on the PowerUnit.

Problem	Cause and remedy
Top indicator is flashing quickly	<p>“Comfort handle not recognised” error</p> <ul style="list-style-type: none"> ■ Remove the Comfort handle and reconnect it (see “Installation and connection – Connecting the Comfort handle”). ■ Remove the battery, wait for 10 seconds and reinsert it.
Middle indicator is flashing quickly	<p>“Motor overheating” error</p> <ul style="list-style-type: none"> ■ Empty and clean the dust container, pre-filter and fine dust filter (see “Maintenance”). ■ Remove the battery, wait for 10 seconds and reinsert it. ■ Wait for approximately 30 minutes before switching the vacuum cleaner back on again.
Bottom and top indicators are flashing quickly	<p>Internal system error</p> <ul style="list-style-type: none"> ■ Remove the battery, wait for 10 seconds, reinsert it and charge it.
The bottom and middle indicators are flashing quickly	<p>“Battery overheating” or “Battery not recognized” error</p> <ul style="list-style-type: none"> ■ Wait for approximately 30 minutes before switching the vacuum cleaner back on again. ■ Insert an original Miele AP01/AP02/AP03 lithium-ion rechargeable battery (HX LA).

Troubleshooting

Many malfunctions and faults that can occur in daily operation can be easily remedied. You can save time and money in many cases, as you do not need to call the Miele Customer Service Department.

Information to help you remedy faults yourself can be found at www.miele.com/service.

The following tables are designed to help you to find the cause of a malfunction or a fault and to resolve it.



Risk of injury caused by rotating roller brush.

You can injure yourself on the rotating roller brush.

Switch the vacuum cleaner off before dealing with any problems. Use the On/Off switch on the Comfort handle to do this.

Problem	Cause and remedy
The vacuum cleaner keeps falling over.	You have configured the vacuum cleaner with the PowerUnit at the top. <ul style="list-style-type: none"> ■ Reassemble the vacuum cleaner so that it is configured with the PowerUnit at the bottom (see “Installation and connection – Assembling the vacuum cleaner”).
The cleaning performance is poor.	The dust container is full. <ul style="list-style-type: none"> ■ Empty and clean the dust container (see “Maintenance”).
	The Electrobrush is dirty/blocked. <ul style="list-style-type: none"> ■ Clean the Electrobrush (see “Maintenance – Cleaning the Electrobrush” and “Removing the roller brush from the Electrobrush”).
Cleaning performance is reduced.	The fine dust filter/pre-filter is soiled. <ul style="list-style-type: none"> ■ Run the interim cleaning function for the fine dust filter (see “Maintenance – Activating the ComfortClean function”). ■ Clean both filters thoroughly (see “Maintenance – Cleaning the pre-filter and fine dust filter”).
	The fine dust filter is worn. <ul style="list-style-type: none"> ■ Insert a new fine dust filter (HX FSF-2).

Problem	Cause and remedy
The roller brush is not rotating.	<p>The roller brush is dirty.</p> <ul style="list-style-type: none"> ■ Clean the roller brush (see “Maintenance – Cleaning the Electrobrush” and “Removing the roller brush from the Electrobrush”).
The operating noise is changing during vacuuming.	<p>The Electrobrush power consumption is automatically set to the optimum level based on the type of flooring and roller brush used.</p> <ul style="list-style-type: none"> ■ The noise is not unusual – the vacuum cleaner is functioning normally.
The Electrobrush switches itself off.	<p>The Electrobrush is overloaded – this can happen on surfaces like deep-pile carpet.</p> <ul style="list-style-type: none"> ■ Switch the vacuum cleaner off and switch it on again at a reduced suction power level. Use the On/Off switch on the Comfort handle to do this.
The vacuum cleaner does not start when it is switched on.	<p>There is no battery inserted or the battery has been inserted incorrectly.</p> <ul style="list-style-type: none"> ■ Insert the battery or check how the battery is positioned (see “Installation and connection” – “Inserting the battery”).
	<p>The rechargeable battery is not sufficiently charged.</p> <ul style="list-style-type: none"> ■ Charge the battery exactly as described in these operating instructions (see “Installation and connection” – “General battery information” and “Charging the battery”).
	<p>An original Miele battery has not been inserted.</p> <ul style="list-style-type: none"> ■ Insert an original Miele AP01/AP02/AP03 lithium-ion rechargeable battery (HX LA).
	<p>The battery was not placed in the PowerUnit when charging it for the first time.</p> <ul style="list-style-type: none"> ■ To activate the battery, it must be placed in the PowerUnit the first time it is charged (see “Installation and connection” – “General battery information” and “Charging the battery”).
	<p>The charging plug is still plugged in.</p> <ul style="list-style-type: none"> ■ Pull the charging plug out of the charging socket on the bottom of the battery.

Service

Information to help you rectify faults yourself and about Miele spare parts can be found at www.miele.com/service.

Contact in case of malfunction

In the event of any faults which you cannot remedy yourself, please contact your Miele Dealer or Miele Service.

Contact information for Miele Service can be found at the end of this document.

Please note that telephone calls may be monitored and recorded for training purposes and that a call-out charge will be applied to service visits where the problem could have been resolved as described in this booklet.

Guarantee

For information on the appliance guarantee specific to your country please contact Miele. See end of this booklet for contact details.

Warranty in the UAE

The appliance warranty is valid for 2 years from date of purchase. For more information on country specific warranty terms and conditions, please contact Miele Customer Service. See end of this booklet for contact details.

Cleaning and care

 Risk of injury caused by rotating roller brush.

You can injure yourself on the rotating roller brush.

Always switch the vacuum cleaner off before cleaning it. Use the On/Off switch on the Comfort handle to do this.

Vacuum cleaner and accessories

 Risk of electric shock from mains voltage.

If moisture gets into the charger, there is a risk of electric shock.

Do not let the charger get wet.

Follow the special cleaning instructions for the dust container in the "Maintenance" section.

The vacuum cleaner and all plastic accessories should be cleaned with a commercially available cleaner suitable for plastic.

 Damage due to unsuitable cleaning agents.

All surfaces are susceptible to scratching. Contact with unsuitable cleaning agents can alter or discolour all surfaces.

Do not use abrasive cleaning agents, glass cleaning agents, all-purpose cleaners or oil-based care products.

Optional accessories

Follow the flooring manufacturer's cleaning and care instructions.

We recommend using only genuine Miele accessories bearing the "ORIGINAL Miele" logo on the packaging. Only these will guarantee the optimum performance of your vacuum cleaner and the best possible cleaning results.

Please note that faults and damage caused by use of accessories which do not bear the "ORIGINAL Miele" logo on the packaging are not covered by the vacuum cleaner warranty.

Purchasing accessories

Original Miele accessories are available from the Miele webshop, the Miele Customer Service Department and from your Miele dealer.

Original Miele accessories are identified by the "ORIGINAL Miele" logo on the packaging.



With 3D4U, Miele also offers free accessories to download for your 3D printer (www.miele.com, Service, 3D4U).

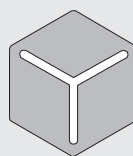

3 D 4 U

Certain models are supplied with one or more of the following accessories as standard.

Electro Compact handheld brush (HX-EC 10)

For intensive cleaning of car seats and carpeted stairs.

Hardfloor Care soft roller (HX HC)

For cleaning delicate hard floors.

Universal brush (HX-UB)

For gentle vacuuming of books, shelves or similar.

Radiator brush (SHB 30)

For dusting radiators, narrow shelves and crevices.

Mattress nozzle (SMD 10)

For vacuuming upholstery, mattresses, cushions, curtains, covers etc.

Crevice nozzle, 300 mm (SFD 10)

Extra long crevice nozzle for cleaning in folds, crevices and corners.

Crevice nozzle, 560 mm (SFD 20)

Flexible crevice nozzle for vacuuming hard to reach places.

Extendable flexible XL crevice nozzle (HX-CNXL)

The flexible crevice nozzle can reach 60 cm for cleaning hard-to-reach areas.

Hose extension (HX-FSH 10)

For increasing the vacuuming radius by maximum 120 cm.

AP01/AP02/AP03 additional battery (HX LA)

For doubling the amount of time the vacuum cleaner can be used for.

Before charging for the first time, you must read the information in “Installation and connection” – “General battery information”.

LS03 (HX LS) charger cradle

For charging the additional battery independently of the appliance, i.e. while the appliance is in use.

Before charging for the first time, you must read the information in “Installation and connection – General battery information”.

Fine dust filter (HX FSF-2)

To continue achieving the best possible cleaning results, replace the fine dust filter that is fitted as standard with a new one after approx. 3 years (see “Maintenance – Cleaning the pre-filter and fine dust filter”).

United Kingdom

Miele Co. Ltd., Fairacres, Marcham Road, Abingdon, Oxon, OX14 1TW
Tel: 0330 160 6600, Internet: www.miele.co.uk, E-mail: info@miele.co.uk

Australia

Miele Australia Pty. Ltd.
ACN 005 635 398
ABN 96 005 635 398
Level 4, 141 Camberwell Road
Hawthorn East, VIC 3123
Tel: 1300 464 353
Internet: www.miele.com.au

China Mainland

Miele Electrical Appliances Co., Ltd.
1-3 Floor, No. 82 Shi Men Yi Road
Jing' an District
200040 Shanghai, PRC
Tel: +86 21 6157 3500
Fax: +86 21 6157 3511
E-mail: info@miele.cn,
Internet: www.miele.cn

Hong Kong, China

Miele (Hong Kong) Ltd.
41/F - 4101, Manhattan Place
23 Wang Tai Road
Kowloon Bay, Hong Kong
Tel: (852) 2610 1025
Fax: (852) 3579 1404
Email:
customerservices@miele.com.hk
Website: www.miele.hk

India

Miele India Pvt. Ltd.
1st Floor, Copia Corporate Suites,
Commercial Plot 9,
Mathura Road, Jasola,
New Delhi - 110025
E-mail: customercare@miele.in
Website: www.miele.in

Ireland

Miele Ireland Ltd.
2024 Bianconi Avenue
Citywest Business Campus
Dublin 24
Tel: (01) 461 07 10
Fax: (01) 461 07 97
E-Mail: info@miele.ie
Internet: www.miele.ie

Kuwait

Miele Kuwait
Al Wazzan United Trading Co.
P. O. Box : 3379
Hawally, 32034 Kuwait
Tel.: 00965-22001010
Fax: 00965-24838292
E-mail: mail@alwazzanunited.com
Website: www.alwazzanunited.com

Malaysia

Miele Sdn Bhd
Suite 12-2, Level 12
Menara Sapura Kencana
Petroleum
Solaris Dutamas No. 1
Jalan Dutamas 1
50480 Kuala Lumpur, Malaysia
Phone: +603-6209-0288
Fax: +603-6205-3768

New Zealand

Miele New Zealand Limited
IRD 98 463 631
8 College Hill
Freemans Bay, Auckland 1011
New Zealand
Tel: 0800 464 353
Internet: www.miele.co.nz

Singapore

Miele Pte. Ltd.
29 Media Circle
#11-04 ALICE@Mediapolis
Singapore 138565
Tel: +65 6735 1191
Fax: +65 6735 1161
E-Mail: info@miele.com.sg
Internet: www.miele.sg

South Africa

Miele (Pty) Ltd.
63 Peter Place, Bryanston 2194
P.O. Box 69434, Bryanston 2021
Tel: (011) 875 9000
Fax: (011) 875 9035
E-mail: info@miele.co.za
Internet: www.miele.co.za

Thailand

Miele Appliances Ltd.
BHIRAJ TOWER at EmQuartier
43rd Floor Unit 4301-4303
689 Sukhumvit Road
North Klongton Sub-District
Vadhana District
Bangkok 10110, Thailand

United Arab Emirates

Miele Appliances Ltd.
Showroom 1, Eiffel 1 Building
Sheikh Zayed Road, Umm Al Sheif
P.O. Box 114782 - Dubai
Tel. +971 4 3044 999
Fax. +971 4 3418 852
800-MIELE (64353)
E-Mail: info@miele.ae
Website: www.miele.ae

Manufacturer: Miele & Cie. KG, Carl-Miele-Straße 29, 33332 Gütersloh, Germany

Miele

Hong Kong, China

Miele (Hong Kong) Ltd.

41/F - 4101, Manhattan Place
23 Wang Tai Road
Kowloon Bay
Hong Kong
Tel: (852) 2610 1025
Fax: (852) 3579 1404
E-mail: customerservices@miele.com.hk
Website: www.miele.hk

Hong Kong, China

Miele (Hong Kong) Ltd.

香港九龍灣宏泰道23號
Manhattan Place 41樓4101室
電話: (852) 2610 1025
傳真: (852) 3579 1404
電郵地址: customerservices@miele.com.hk
網址: www.miele.hk

Miele Experience Centre

G/F & 1/F, Lee Garden Six
111 Leighton Road
Causeway Bay
Hong Kong
Tel: (852) 2890 1018
Fax: (852) 3579 1401
E-mail: ExperienceCentre@miele.com.hk

Miele陳列室

香港銅鑼灣禮頓道111號利園6期地下及一樓
電話: (852) 2890 1018
傳真: (852) 3579 1401
電郵地址: ExperienceCentre@miele.com.hk

International Head Office

Miele & Cie. KG
Carl-Miele-Straße 29
33332 Gütersloh
Germany