

## THE BENCHMARK MACHINES

**OPL** | ON-PREMISE LAUNDRY



No Heater



Steam Indirect



Electric Heating



## PWM 920 | 45 lbs. PERFORMANCE PLUS

### FEATURES

- M Touch Pro Plus freely programmable color display
- Short program cycles
- Patented Honeycomb Drum 2.0
- 3D imbalance monitoring
- G-force of 462
- High durability: tested for 30,000 operating hours
- Safe disinfection
- Low consumption values

#### Exclusive to Miele

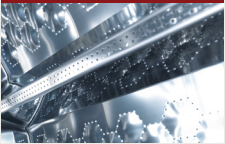

### Patented Honeycomb Drum 2.0

The scoop rib perforations in the Honeycomb Drum 2.0 cause water to shower down on the load, guaranteeing thorough soaking.



### Short Program Cycles

Premium commercial technology allows you to benefit from quick and efficient program cycles.



### EcoSpeed Patented Wash Process

The EcoSpeed washing process features an optimized drum rhythm and enhanced washing action, allowing intensive cleaning performance with reduced water usage.



### Proven Hygiene

Our washing machines in the Benchmark series remove more than 99.9% of all viruses (including coronaviruses).\*

\*May not apply for No Heater version.

Model	Heat Type	Electrical Specification Voltage/Hz/Phase (Amp)	Color	Material No.	Article No.
PWM 920	No Heater	240/60/1 (2 x 20 A)	Iron Grey	11803320	51920029NAM
PWM 920	No Heater	240/60/1 (2 x 20 A)	Stainless Steel	11803310	51920059NAM
PWM 920	Steam	240/60/1 (2 x 20 A)	Iron Grey	11803330	51920030NAM
PWM 920	Steam	240/60/1 (2 x 20 A)	Stainless Steel	11803340	51920031NAM
PWM 920	Steam	208, 240/60/3 (3 x 15 A)	Stainless Steel	12084520	51920032NAM
PWM 920	Electric	208, 240/60/3 (3 x 60 A)	Stainless Steel	11803300	51920017NAM

## Specifications

Capacity	45 lbs. (20 kg)
Cylinder Diameter	16 <sup>5/16</sup> in. (415 mm)
Cylinder Depth	18 <sup>1/8</sup> in. (461 mm)
Cylinder Volume	6.4 cu.ft. (180 l)
Machine Dimensions (WxDxH)	36 <sup>3/8</sup> x 41 <sup>1/2</sup> x 57 <sup>1/16</sup> in. (924 x 1,054 x 1,450 mm)
Door Opening	15 <sup>5/16</sup> in. (415 mm)
Floor to Door	19 <sup>7/8</sup> in. (505 mm)
Reversible Door	No
Shipping Dimensions (WxDxH)	47 <sup>5/8</sup> x 44 <sup>1/2</sup> x 62 <sup>3/8</sup> in. (1,210 x 1,130 x 1,585 mm)
Net Weight	959 lbs. (435 kg)
Crated Weight	1,012 lbs. (459 kg)
Wash Speed	38 rpm
Extract Speed	1,075 rpm
G-force	462
Water Inlets	8 x 3/4 in. (203 x 19 mm)
Hot Water (No Heater version)	1 x 1 in. (26 x 26 mm)
Steam Inlets (Steam version)	2 x 1/2 in. (51 x 13 mm)
Drain Diameter	2 <sup>3/4</sup> in. (70 mm)
Recommended Water Pressure	14.5 -145 psi
Water Flow	52.8 gal/min. (200 l/min.)
Min. Recommended Distance Between Machines	2 in. (50 mm)
Agency Approvals	Intertek

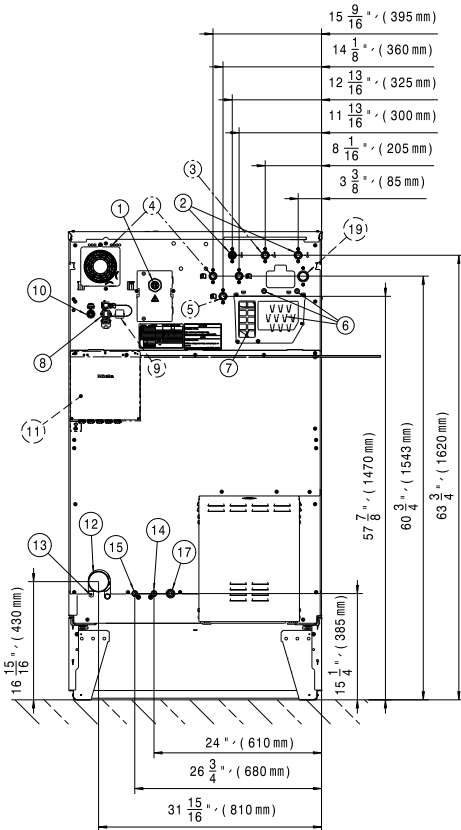
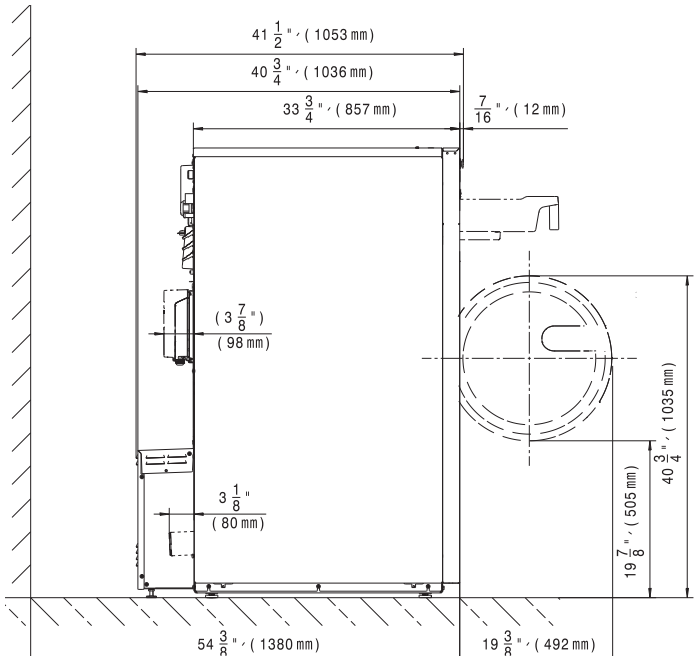
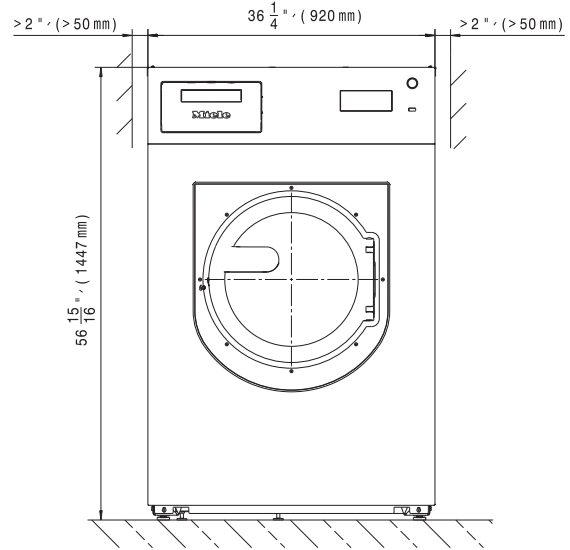

Heating	Voltage (Voltage/Hz/Phase)	Wire	Circuit Breaker Amps	Running Amps	Total Power (kW)
No Heater	240/60/1	2 Wire + Ground	20	17	3.1
Steam	240/60/1	2 Wire + Ground	20	17	3.1
Steam	208, 240/60/3	3 Wire + Ground	15	10.46	3.0
Electric	208, 240/60/3	3 Wire + Ground	60	49.2	20.6

Specifications subject to change without notice or obligation.  
 Contact Miele USA at (800) 991-9380 or Miele Canada at  
 (888) 325-3957 for dimensions not shown or for clarification.