

## THE BENCHMARK MACHINES

OPL ON-PREMISE LAUNDRY



No Heater



Electric Heating



## PWM 912 | 25 lbs. PERFORMANCE PLUS

### FEATURES

- M Touch Pro Plus freely programmable color display
- Short program cycles
- Patented Honeycomb Drum 2.0
- 3D imbalance monitoring
- G-force of 458
- High durability: tested for 30,000 operating hours
- Safe disinfection
- Low consumption values

#### Exclusive to Miele



### Patented Honeycomb Drum 2.0

The scoop rib perforations in the Honeycomb Drum 2.0 cause water to shower down on the load, guaranteeing thorough soaking.



### Short Program Cycles

Premium commercial technology allows you to benefit from quick and efficient program cycles.



### EcoSpeed Patented Wash Process

The EcoSpeed washing process features an optimized drum rhythm and enhanced washing action, allowing intensive cleaning performance with reduced water usage.



### Proven Hygiene

Our washing machines in the Benchmark series remove more than 99.9% of all viruses (including coronaviruses).\*

\*May not apply for No Heater version.

Model	Heat Type	Electrical Specification Voltage/Hz/Phase (Amp)	Color	Material No.	Article No.
PWM 912	No Heater	240/60/1 (2 x 20 A)	Iron Grey	11803090	51912009NAM
PWM 912	No Heater	240/60/1 (2 x 20 A)	Stainless Steel	11803080	51912059NAM
PWM 912	Electric	208, 240/60/3 (3 x 30 A)	Stainless Steel	11803070	51912017NAM

## Specifications

Capacity	25 lbs. (11 kg)
Cylinder Diameter	16 <sup>5</sup> / <sub>16</sub> in. (415 mm)
Cylinder Depth	15 <sup>3</sup> / <sub>8</sub> in. (391 mm)
Cylinder Volume	3.9 cu.ft. (110 l)
Machine Dimensions (WxDxH)	31 <sup>7</sup> / <sub>16</sub> x 40 <sup>15</sup> / <sub>16</sub> x 53 <sup>1</sup> / <sub>8</sub> in. (799 x 1,023.5 x 1,350 mm)
Door Opening	16 <sup>5</sup> / <sub>16</sub> in. (415 mm)
Floor to Door	18 <sup>7</sup> / <sub>16</sub> in. (468 mm)
Reversible Door	No
Shipping Dimensions (WxDxH)	42 <sup>15</sup> / <sub>16</sub> x 44 <sup>1</sup> / <sub>2</sub> x 58 <sup>1</sup> / <sub>4</sub> in. (1,090 x 1,130 x 1,480 mm)
Net Weight	626 - 668 lbs. (284-303 kg)
Crated Weight	677-939 lbs. (307-426 kg)
Wash Speed	43 rpm
Extract Speed	1,150 rpm
G-force	458
Water Inlets	7 x <sup>3</sup> / <sub>4</sub> in. (178 x 19 mm)
Hot Water (No Heater version)	1 x 1 in. (26 x 26 mm)
Drain Diameter	2 <sup>3</sup> / <sub>4</sub> in. (70 mm)
Recommended Water Pressure	14.5 - 145 psi
Water Flow	52.8 gal/min. (200 l/min.)
Min. Recommended Distance Between Machines	2 in. (50 mm)
Agency Approvals	Intertek

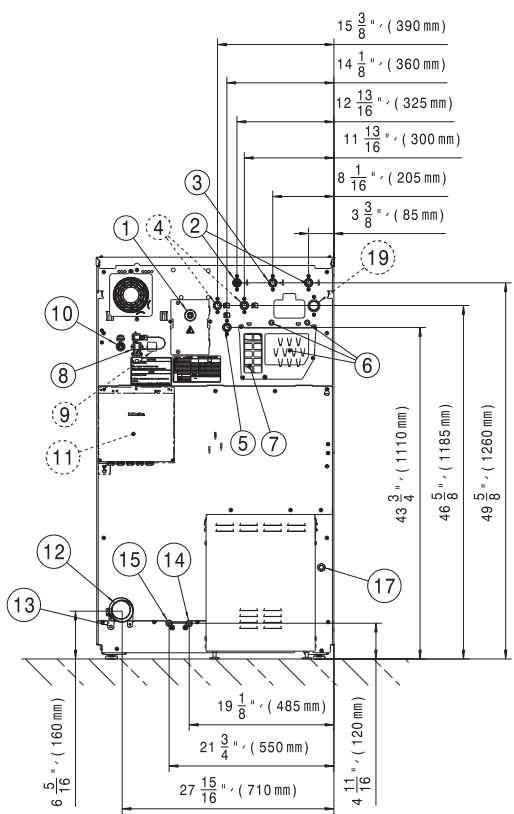
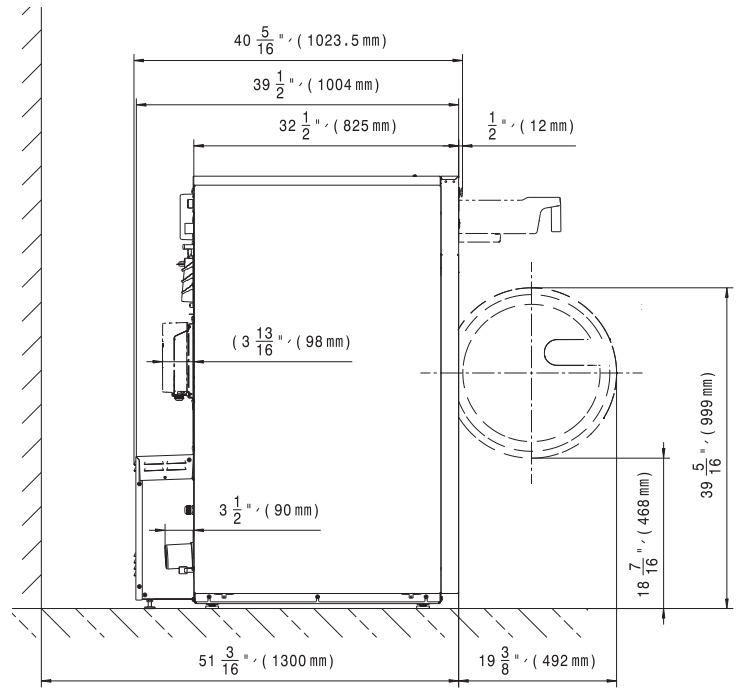
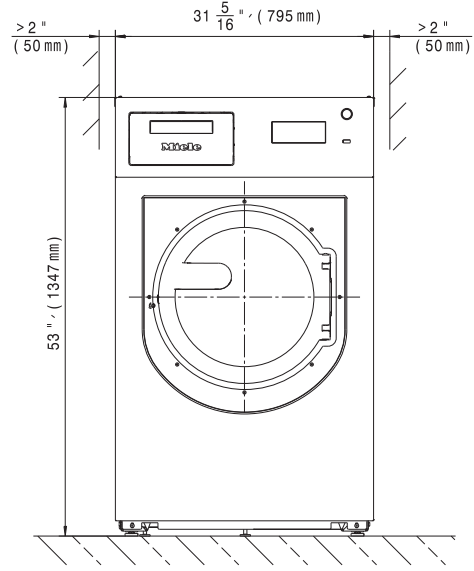

Heating	Voltage (Voltage/Hz/Phase)	Wire	Circuit Breaker Amps	Running Amps	Total Power (kW)
No Heater	240/60/1	2 Wire + Ground	20	16	2.3
Electric	208, 240/60/3	3 Wire + Ground	30	24.6	10.4

Specifications subject to change without notice or obligation.  
 Contact Miele USA at (800) 991-9380 or Miele Canada at (888) 325-3957 for dimensions not shown or for clarification.