

Operating and installation instructions Built-in coffee machine



To avoid the risk of accidents or damage to the appliance it is **essential** to read these instructions before it is installed and used for the first time.

Caring for the environment

Disposing of the packaging material

The packaging material is used for handling and protects the appliance from transport damage. The packaging material used is selected from materials which are environmentally friendly for disposal and can generally be recycled.

Recycling the packaging material reduces the use of raw materials. Use material-specific collection points for valuable materials and take advantage of return options.

Disposing of your old appliance

Electrical and electronic appliances contain many valuable materials. They also contain certain materials, compounds and components which were essential for their correct functioning and safety. These could be hazardous to human health and to the environment if disposed of with household waste or if handled incorrectly. Please do not, therefore, dispose of your old appliance with household waste.



Instead, please make use of officially designated collection and disposal points to dispose of and recycle electrical and electronic appliances in your local community, with your dealer or with Miele, free of charge. By law, you are solely responsible for deleting any personal data from the old appliance prior to disposal. You are legally obliged to remove any old batteries which are not securely enclosed by the appliance and to remove any lamps without destroying them, where this is possible. These must be taken to a suitable collection point where they can be handed in free of charge. Please ensure that your old appliance poses no risk to children while being stored for disposal.

Caring for the environment	2
Warning and Safety instructions	7
Guide to the machine	13
The milk container	15
Central spout with cup rim sensor	15
Symbols in the display	16
Operation	17
Touch display	17
Operating actions	18
Miele@home	21
Before using for the first time	22
Switching on for the first time	22
Setting up the bean system	24
Bean system	27
Changing bean system settings (Type of beans)	27
Renaming the bean types	27
Changing how the bean containers are assigned	28
Filling the water container	29
Switching on and off	30
Switching the coffee machine on	30
Switching the coffee machine off	30
Preparing for an extended period of inactivity	30
Making drinks	31
Coffee	31
Coffee drinks made with and without milk	31
The milk	32
Filling and inserting the milk container	32
Making a coffee	33
Cancelling a drink	33
DoubleShot	33
Making 2 portions ☐	34
Coffee pot	34
Tea	34
Making tea	35
Starting the TeaTimer manually	36
Teapot	36
Dispensing warm or hot water	36
Changing the portion size	36

Contents

Expert mode	37
Switching Expert mode on and off.....	37
Expert mode: assigning bean containers.....	37
Expert mode: changing the portion size	37
Degree of grinding	38
Identifying the ideal degree of grinding.....	38
Adjusting the degree of grinding	38
Parameters	39
Type of beans.....	39
Quantity of coffee.....	39
Pre-brewing the ground coffee.....	39
Brewing temperature	39
Portion size.....	39
Displaying and changing parameters	40
Resetting drinks.....	40
Profiles	41
Creating a profile	41
Editing profiles	41
Setting when the profile should change	41
Profiles: creating and editing drinks	42
MyMiele	43
MobileStart 	44
Settings	45
Displaying and changing settings	45
Language.....	45
Time.....	45
Date	45
Start screen.....	45
Timer	46
Appliance timer.....	46
Maintenance timer	46
TeaTimer.....	46
Volume	47
Display	47
Brightness.....	47
Colour scheme.....	47
QuickTouch.....	47
Lighting.....	47
Info (display information)	47
Altitude.....	47

Performance mode.....	47
Eco mode	48
Barista mode	48
Latte mode.....	48
Party mode	48
Water hardness.....	48
Movement sensor	49
System lock 	50
Miele@home	50
Remote control	50
SuperVision	50
RemoteUpdate	51
Software version.....	52
Legal information	52
Showroom programme (demo mode).....	52
Factory defaults	52
Cleaning and care	53
Overview of cleaning intervals.....	53
Cleaning by hand or in the dishwasher	54
Unsuitable cleaning agents.....	55
Cleaning the drip tray and waste container.....	55
Cleaning the drip tray cover.....	57
Cleaning the water container.....	58
Cleaning the central spout	58
Cleaning the cup rim sensor	61
Cleaning the milk container with lid	61
Cleaning the milk valve (daily)	62
Removing and cleaning the milk valve (once a month).....	62
Cleaning the bean containers.....	65
Removing the brew unit and cleaning it by hand.....	66
Cleaning the interior, inside of the appliance door and drip tray.....	68
Cleaning the appliance front.....	69
Maintenance programmes	69
Opening the Maintenance menu	70
Rinsing the machine.....	70
Rinsing the milk pipework	70
Maintenance programme: Clean the milk pipework	70
Degreasing the brew unit and cleaning the interior	71
Descaling the machine	73
Automatic cleaning and descaling	76
Please note before and during the automatic maintenance programmes:.....	76
Automatic cleaning	77

Contents

The Miele cleaning cartridge	77
Replacing the cleaning cartridge	78
Automatic descaling	79
The Miele descaling cartridge	79
Replacing the descaling cartridge	80
Removing the descaling cartridge	80
Fitting the descaling cartridge	81
Choosing not to use a descaling cartridge	81
Maintenance Timer	81
Cancelling automatic cleaning and descaling	82
Problem solving guide	83
Messages in the display	83
Unusual performance of the coffee machine	86
Faults with automatic cleaning and/or descaling	89
Unsatisfactory results	91
After sales service and warranty	94
Contact in the event of a fault	94
Warranty	94
Accessories	95
Installation	96
Electrical connection	96
Building-in dimensions	97
Installation in a tall unit	97
Installation and connections	98
Building in the coffee machine	99
Door opening limiters	100
Technical data	102
EU Conformity declaration	103
UK Conformity declaration	104
Copyrights and Licences	106

Warning and Safety instructions

This coffee machine complies with all the stipulated safety requirements. Inappropriate use can, however, lead to personal injury and material damage.

Read the operating instructions carefully before using the coffee machine. They contain important information on safety, installation, use and maintenance. This prevents both personal injury and damage to the coffee machine.

In accordance with standard IEC 60335-1, Miele expressly and strongly advises you to read and follow the instructions in the chapter on installing the coffee machine as well as the safety instructions and warnings.

Miele cannot be held liable for injury or damage caused by non-compliance with these instructions.

Keep these operating instructions in a safe place and pass them on to any future owner.

Warning and Safety instructions

Correct application

- ▶ This coffee machine is intended for home use.
- ▶ This coffee machine is not intended for outdoor use.
- ▶ This coffee machine must not be used at altitudes above 2000 m.
- ▶ It must only be used as a domestic appliance to make espresso, cappuccino, latte macchiato, tea etc. Any other use is not permitted.
- ▶ This coffee machine can only be used by people with reduced physical, sensory or mental capabilities, or lack of experience and knowledge, if they are supervised whilst using it, or have been shown how to use it in a safe way and recognise and understand the consequences of incorrect operation.

Safety with children

 Danger of burning and scalding on the dispensing spouts.

Children's skin is far more sensitive to high temperatures than that of adults.

Ensure children do not touch hot surfaces of the coffee machine or place parts of their body under the dispensing spouts.

- ▶ Install the coffee machine where it is out of the reach of children.
- ▶ Children under 8 years of age must be kept away from the coffee machine unless they are constantly supervised.
- ▶ Children aged 8 and older may only use the coffee machine without supervision if they have been shown how to use it in a safe manner.
Children aged 8 and older must be aware of the potential dangers caused by incorrect operation.
- ▶ Please supervise children in the vicinity of the coffee machine and do not allow them to play with it.
- ▶ Young children must not be allowed to clean the coffee machine at all. Cleaning may only be carried out by children 8 years of age or older under the supervision of an adult.
- ▶ Remember that coffee and espresso are not suitable drinks for children.

Warning and Safety instructions

▶ Danger of suffocation! Whilst playing, children may become entangled in packaging material (such as plastic wrapping) or pull the packaging material over their head, presenting the risk of suffocation. Keep packaging material away from children.

Technical safety

▶ Installation work or repairs should only be carried out by a Miele authorised technician. Unauthorised or incorrect installation work or repairs can pose considerable danger to users.

▶ A damaged coffee machine could be dangerous. Before building in the machine, check it for any externally visible damage. Do not use a damaged machine.

▶ To avoid the risk of damage to the machine, make sure the connection data (voltage and frequency) on the data plate corresponds to the household supply, before connecting the machine to the mains supply. Consult a qualified electrician if in any doubt.

▶ The electrical safety of this coffee machine can only be guaranteed when correctly earthed. It is essential that this standard safety requirement is met. If in any doubt please have the electrical installation tested by a qualified electrician.

▶ Temporary or permanent operation on an autonomous power supply system or a power supply system that is not synchronised with the mains power supply (e.g. island networks, back-up systems) is possible. A prerequisite for operation is that the power supply system complies with the specifications of EN 50160 or an equivalent standard.

The function and operation of the protective measures provided in the domestic electrical installation and in this Miele product must also be maintained in isolated operation or in operation that is not synchronised with the mains power supply, or these measures must be replaced by equivalent measures in the installation. As described, for example, in the current version of BS OHSAS 18001–2 ISO 45001.

▶ Do not connect the machine to the mains electricity supply by a multi-socket adapter or an extension lead. These are a fire hazard and do not guarantee the required safety of the appliance.

▶ The coffee machine must not be used in a non-stationary location (e.g. on a ship).

Warning and Safety instructions

- ▶ For safety reasons, this machine may only be used when it has been built in.
- ▶ If the coffee machine is to be built in above another appliance, there must be a full-width, closed intermediate shelf between them (except when it is combined with a Gourmet drawer or a built-in vacuum drawer).
- ▶ Only use the coffee machine in rooms where the ambient temperature is between +16 °C and +38 °C.
- ▶ A minimum installation height of 850 mm must be observed.
- ▶ This coffee machine must not be installed behind a closed cabinet door because heat and moisture can build up behind it. This can result in damage to the machine and/or furniture unit.
- ▶ The coffee machine must be disconnected from the electricity supply during repair work.
- ▶ While the machine is under warranty, repairs should only be undertaken by a Miele authorised service technician. Otherwise the warranty is invalidated.
- ▶ Never open the outer casing of the machine. Tampering with electrical connections or components and mechanical parts is highly dangerous to the user and can cause operational faults or electric shock.

Correct use



Danger of burning and scalding on the dispensing spouts.

The liquids and steam dispensed are very hot.

Keep well away from the area underneath the spouts when hot liquids and steam are being dispensed.

Do not touch hot components.

Hot liquid or steam could spatter from the nozzles. Ensure that the central spout is clean and fitted correctly.

Before opening the door, remove any containers from the drip tray in the machine door.

Water in the drip tray can also be very hot. Take care when emptying it.

Warning and Safety instructions

 Danger of injury to the eyes.

Never look directly at the lighting or use optical instruments to look at it.

- ▶ Please note the following regarding water:
 - The water quality must conform to the requirements for drinking water in the country in which the coffee machine is being used.
 - Only use cold, fresh tap water to fill the water container. Hot or warm water or other liquids can damage the coffee machine.
 - Change the water every day to prevent a build-up of bacteria.
 - Do not use carbonated water.
- ▶ Only put roasted coffee beans in the bean containers. Do not place coffee beans which have been treated with additives or ground coffee inside the bean containers.
- ▶ Do not fill the bean containers with any type of liquid.
- ▶ Do not use green (unroasted) coffee beans or mixtures of coffee beans which contain green coffee beans. Green coffee beans are very hard and still contain residual moisture. These can damage the coffee machine grinder as soon as grinding begins.
- ▶ Do not use coffee beans which have been treated with caramel, sugar or other substances including sugary liquids. Sugar will damage the coffee machine.
- ▶ If decaffeinated coffee beans are used after dispensing a drink with caffeinated beans, there may still be residues from the caffeinated beans in the grinder or brew chamber. Discard the first coffee drink when using decaffeinated coffee.
- ▶ Only use milk without additives. Additives in milk usually contain sugar and this will stick to the milk pipework.
- ▶ If using dairy milk make sure that it has been pasteurised.
- ▶ When making tea, please follow the instructions on the packaging.
- ▶ Do not place flaming alcohol mixtures underneath the central spout. The flames could ignite plastic components and cause them to melt.
- ▶ Do not swing from or hang anything on the machine front when it is open as this could damage the hinges on the coffee machine.
- ▶ The machine must not be used for cleaning objects.

Warning and Safety instructions

Accessories and spare parts

- ▶ Miele can only guarantee the safety of the machine when original Miele spare parts are used. Faulty components must only be replaced by genuine Miele original spare parts.
- ▶ Only use original Miele accessories. If other parts are used, warranty, performance and/or product liability claims will be invalidated.
- ▶ Miele will guarantee to supply functional spare parts for a minimum of 10 years and up to 15 years following the discontinuation of your coffee machine.

Cleaning and care



- ▶ Clean the coffee machine and the milk flask daily, particularly before using them for the first time.
- ▶ All parts of the milk system need to be cleaned thoroughly and regularly. Milk contains bacteria which proliferate rapidly with inadequate cleaning.
- ▶ If you do not make use of the automatic descaling and cleaning functions, you must regularly run the maintenance programmes for cleaning the milk pipework and the brew unit, and for carrying out descaling. Miele cannot be held liable for damage that results from not cleaning and/or descaling the machine properly, or from using the wrong cleaning/descaling agent or an unsuitable solution concentration.
- ▶ Do not use a steam cleaner to clean this machine. Steam could reach electrical components and cause a short circuit.
- ▶ Used coffee grounds should be disposed of with the organic rubbish or on the compost heap. Do not empty them down the sink, as they could block it.

For machines with stainless steel surfaces:

- ▶ Do not use sticky notes, transparent adhesive tape, masking tape or other types of adhesive on the stainless steel surfaces. These will damage the stainless steel surfaces, causing them to lose their dirt-repellent protective coating.
- ▶ The finish on stainless steel surfaces is susceptible to scratching. Even magnets can cause scratching.

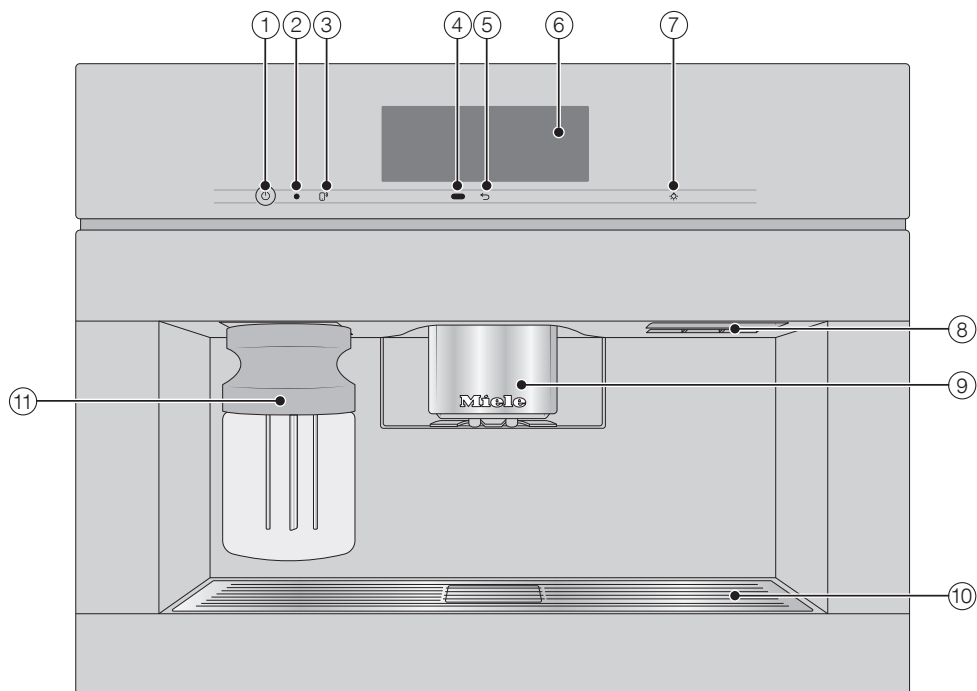
Exterior view



- ① On/Off button ①
- ② Optical interface (for the Miele Customer Service Department only)
- ③ MobileStart sensor 
- ④ Movement sensor
- ⑤ "Back"  sensor
- ⑥ Touch display
- ⑦ "Light" sensor 
- ⑧ Door handle
- ⑨ Height-adjustable central spout with lighting
- ⑩ Drip tray cover
- ⑪ Milk flask

Guide to the machine

Interior view

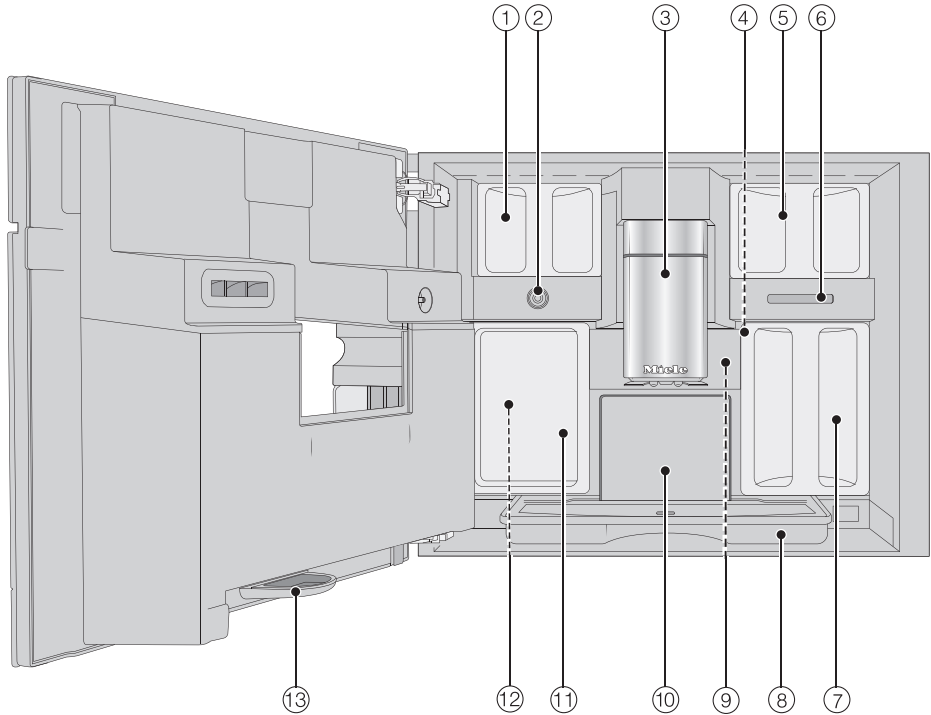

- ① Bean containers (Type A and Type C)
- ② Milk valve
- ③ Height-adjustable central spout with lighting
- ④ Grinder setting
- ⑤ Bean container (Type B)
- ⑥ Fan outlet
- ⑦ Water container
- ⑧ Drip tray with lid
- ⑨ Brew unit
- ⑩ Waste container
- ⑪ Maintenance container
- ⑫ Receptacles for cleaning and descaling cartridges (including adapters)
- ⑬ Drip tray

The milk container

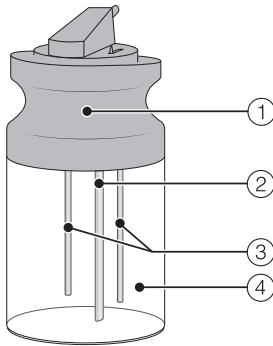

- ① Lid
- ② Milk suction tube
- ③ Sensor
- ④ Glass flask

Central spout with cup rim sensor

The central spout with cup rim sensor features automatic spout adjustment. Thanks to this spout adjustment function, the central spout moves down automatically at the start of a drink preparation process and the cup rim sensor stops it at the optimum height for the cups or glasses being used.

The central spout and cup rim sensor **cannot** be manually adjusted.

When the coffee machine is switched off, the central spout will be in the middle position.

When a maintenance programme is being carried out, the central spout will move to the height of the maintenance container or into a low maintenance position.

Make sure that the central spout is in the top or middle position before you open the door.

Guide to the machine

Symbols in the display

The display shows symbols as well as text, e.g. symbols for the various drinks. Some of these are explained below.

Symbol	Explanation
	This symbol indicates that there is additional information and advice about using the coffee machine. Select <i>OK</i> to confirm the information.
	This symbol indicates the “Settings” menu and the “Language” menu option.
	This symbol appears if the system lock is activated. Operation is locked.
	The symbol and the desired switching-on time appear in the display 23:59 hours before the coffee machine is due to switch on if the On at timer and setting for displaying the time are activated (see “Settings – Timer”).
	This symbol appears during the Clean the milk pipework maintenance programme and during automatic cleaning. (This symbol is also found on the water container: fill up to this mark with water.)
	This symbol appears while the appliance is being descaled. (This symbol can also be found on the water container: fill up to this mark).
	This symbol and a fault code will appear if a fault occurs.
	If Miele@home has been activated for the coffee machine, these symbols represent the quality/status of the WiFi connection, indicating the strength in increments from strong to not connected.
	The “Remote control” symbol appears if Miele@home has been set up for the coffee machine and the setting Remote control On has been selected.
	The “SuperVision” symbol appears if Miele@home has been set up for the coffee machine and the setting SuperVision SuperVision display On has been selected.



Touch display

The delicate touch display can be scratched by pointed or sharp objects, e.g. pens.

Only touch the display with your fingers.

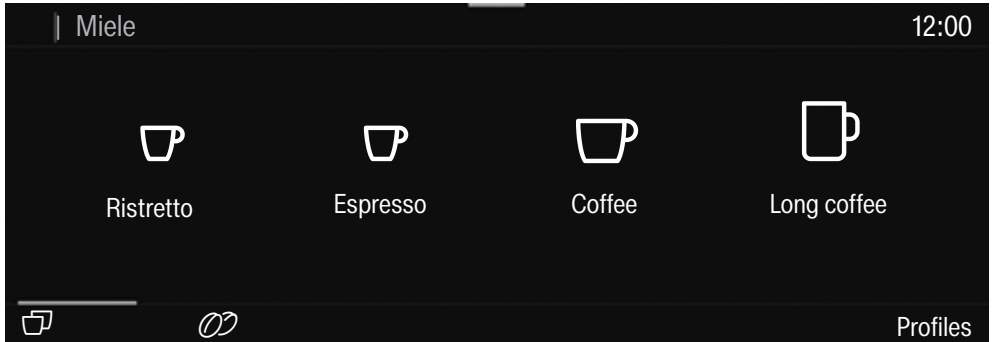
The touch display is split into multiple areas.



The menu path appears on the left of the **header**. If you touch a menu name in the header, the display will switch to that menu. To switch to the start screen, touch . The time of day is shown on the right of the header. Additional symbols may also appear, e.g. TeaTimer .

The current menu and menu options are shown in the **centre**. You can scroll to the right or left by swiping your finger across the display to the right or left.

The options that appear in the **footer** vary according to which menu is selected; e.g. DoubleShot , Save or OK.

Operation

Operating actions

All the selectable options are displayed in black or white according to your selected colour scheme.

Each time you touch a possible option, the relevant characters (word and/or symbol) light up **orange**.

Selecting a menu option

- Touch the field or value you want in the display.

Scrolling

You can scroll left or right.

- Swipe the screen by placing your finger on the touch display and moving it in the direction you want.

The bar at the bottom shows you where you are in the current menu.

Exiting a menu

- Touch the ↩ sensor. Alternatively, touch the higher-level menu name within the menu path.

Entries made before this which have not been confirmed with *OK* will not be saved.

Tip: Touching the ↩ sensor three times in succession will take you to the drinks menu.

Entering numbers with the roller

- Swipe the roller up or down until the value you want is displayed centrally in orange.
- Confirm with *OK*.

Entering numbers using the numerical keypad

- Touch the centrally displayed orange value and keep your finger on it until the numerical keypad appears.

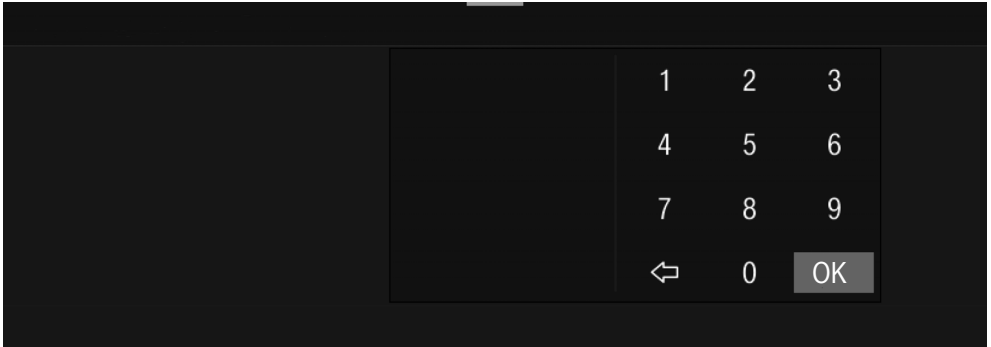

- Select the value you want: as soon as you enter a valid value, *OK* turns green. Use the ↶ arrow to delete the last number entered.
- Confirm with *OK*.

Entering a name

Letters are entered using a keyboard. It is best to select short names.

- Touch the letters or characters you want.

Tip: Use the ↶ arrow to delete the last entered character.

- Touch *Save*.

Displaying the context menu

When you are in certain menus, a context menu can be displayed, e.g. for configuring drinks.

- For instance, you can touch the name of a drink and keep your finger on it until the context menu opens.
- To close the context menu, touch an area of the display located outside of the menu window.

Operation

Moving entries

You can change the order of the entries in the drinks menu, in Profiles and in MyMiele.

- Touch an entry and keep your finger on it until the context menu appears.
- Select Move.

An orange border appears around the entry.

- Touch the selected entry and move it to the required location without taking your finger off the display.

Help

Context-sensitive help is available for certain functions. In this case, Help appears in the bottom line.

- Touch Help to display information in text and pictures.
- Touch Close to return to the previous menu.

Pull-down menu

Among other things, the pull-down menu provides access to a schematic representation of the bean containers and to Expert mode.

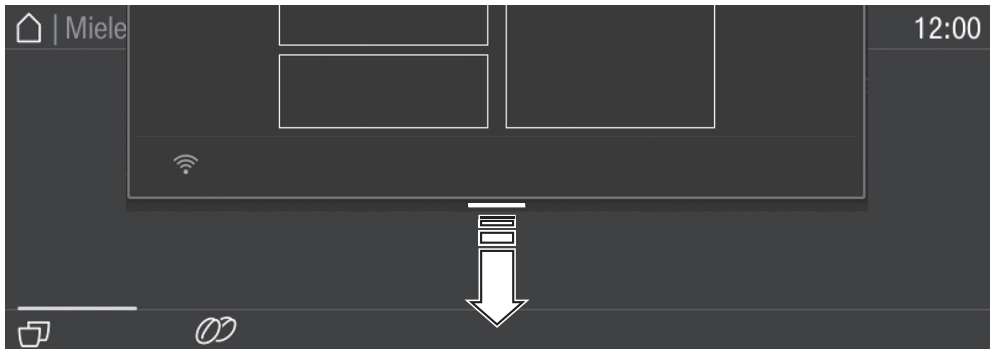

- Touch the orange line at the top edge of the screen and drag down with your finger.

Active settings are highlighted in orange.

- To close the pull-down menu, drag it back up to the top or touch an area of the display located outside of the menu window.

Your coffee machine is equipped with an integrated WiFi module.

Before installing the coffee machine in its final installation site, ensure that the signal from your WiFi network is strong enough.

To use this feature, you will need:

- A WiFi network
- The Miele app
- A Miele user account (this can be created from the Miele app)

The Miele app will guide you through the process of connecting your coffee machine to your home WiFi network.

Once your coffee machine is connected to your WiFi network, you can use the Miele app to carry out activities such as the following:

- Calling up information on the operating status of your coffee machine
- Changing settings on your coffee machine
- Controlling your coffee machine remotely

Connecting your coffee machine to your WiFi network will increase energy consumption, even when the machine is switched off.

Availability of the WiFi connection

The WiFi connection shares a frequency range with other appliances (including microwave ovens and remote control toys). This can give rise to sporadic or even complete connection failures. Therefore, the availability of featured functions cannot be guaranteed.

Miele@home availability

The ability to use the Miele app depends on the availability of the Miele@home service in your country.

The Miele@home service is not available in every country.

For information about availability, please visit www.miele.com.

Miele App

The Miele App is available to download free of charge from the Apple App Store® or from the Google Play Store™.



Before using for the first time

Have the following to hand (included with delivery) when setting the machine up for the first time:

- Miele cleaning cartridge
- Miele descaling cartridge

Switching on for the first time

- Touch the On/Off button ①.

Selecting the display language

- Select the desired display language.

You might also be asked for your location.

The choice of location determines how the time of day is displayed, e.g. in the 12 or 24-hour format, as well as how units are displayed and so on.

Setting up the network (Miele@home)

You can connect your coffee machine to your home WiFi network.

When you start it up for the first time, the following appears in the display: Set up Miele@home?

Tip: You can also choose to set up Miele@home for your coffee machine at a later point. In this case, select *Skip*.

- Make sure that your WiFi network signal is sufficiently strong in the coffee machine's final installation site.
- Touch *Continue*.
- Select the connection method you wish to use.
- Follow the instructions provided in the coffee machine display and in the Miele app.

Connection successfully established will appear in the display.

- Touch *Continue* to proceed with initial set-up.

Setting the date

- Set today's date.
- Confirm with *OK*.

Setting the time of day

- Set the current time of day.
- Confirm with *OK*.

If the coffee machine has been connected to a WiFi network and is signed into the Miele app, the time will be synchronised based on the location setting in the Miele app.

Setting the water hardness level

Contact your local water supplier to find out your local water hardness range if necessary.

More information can be found under "Settings – Water hardness".

- Enter your local water hardness (in °dH) and confirm with *OK*.

Setting up automatic cleaning and descaling

Information about automatic cleaning and descaling will appear in the display.

- Confirm with *OK*.

Tip: Touch *Help* to display an illustrated guide.

Before using for the first time

Fitting the cleaning cartridge

You will now be prompted to fit the cleaning cartridge.



- Open the appliance door.

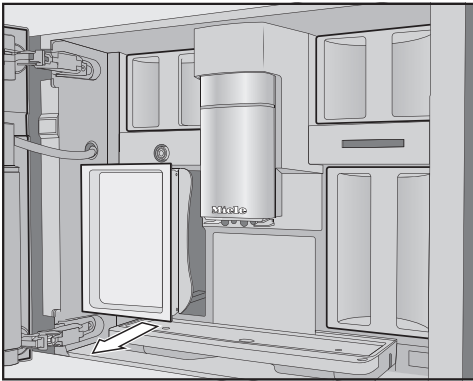

- Remove the maintenance container on the left-hand side.

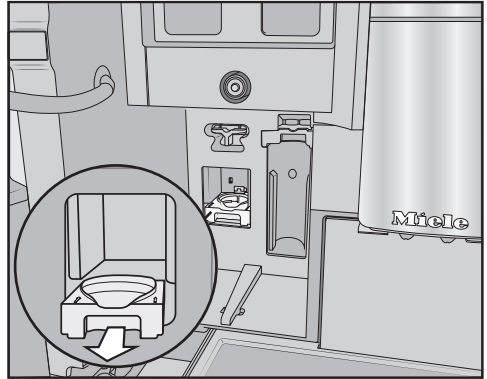

- Pull the cleaning cartridge holder forwards to remove it.
- Take the cleaning cartridge out of its packaging.
- Unscrew the screw cap.

The screw cap is no longer required.



- Screw the cleaning cartridge into the holder upside down.
- Push the holder and cartridge into the coffee machine until the holder audibly clicks into place.

Before using for the first time

Fitting the descaling cartridge

- Take the descaling cartridge out of its packaging.

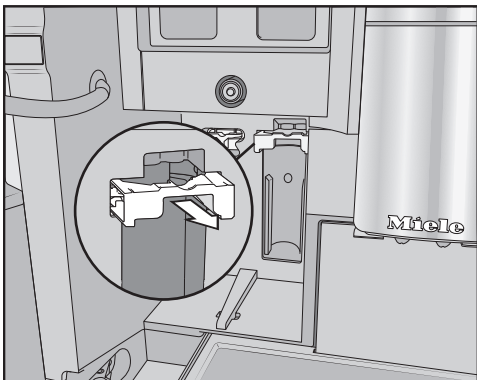

- Pull the descaling cartridge holder forwards.
- Fit the descaling cartridge and push it upwards as far as it will go.
- Slide the descaling cartridge holder back into place.
- Put the maintenance container back inside the appliance.
- Close the appliance door.

The descaling cartridge will fill with water the next time the appliance is switched off.

Always wait for the coffee machine to switch itself off. Do not force the machine to switch off.

Once the cleaning and descaling cartridges have been fitted, a message will appear regarding the current start time set for automatic cleaning and descaling.

- If you want to change the start time, touch **Timer** and select the required time.
- Confirm with **OK**.

You can also adjust the start time for automatic cleaning and descaling at a later point.

Selecting the Performance mode

You can select the appropriate mode to suit your personal preferences (see “Settings – Performance mode”).

- **Eco mode:** This is an energy-saving mode.
 - **Barista mode:** This mode has been optimised for unadulterated coffee enjoyment.
 - **Latte mode:** In this mode, milk-based drinks can be prepared within a much shorter space of time.
- Select the mode you want.

The coffee machine is now successfully set up for use. You can now fill the bean system.

Setting up the bean system

After setting up the coffee machine, you will be prompted to set up the bean system. The coffee machine will assist you when first filling and naming the bean containers.

- Touch **Yes**.

If you select **No**, the assistant for setting up the bean system will not be shown again.

Filling the bean containers

The coffee machine has 2 bean container drawers on the top left and right.

Before using for the first time

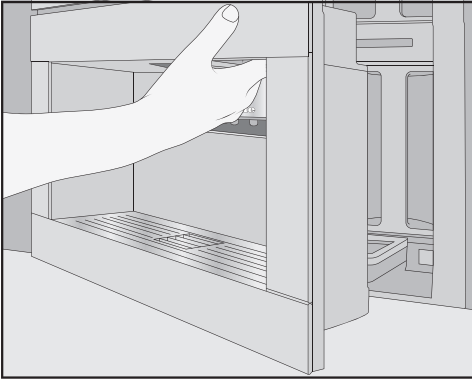

- Open the appliance door.

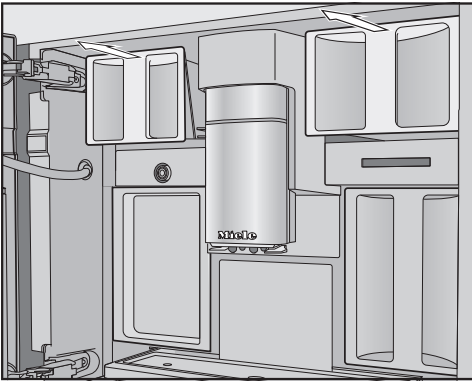

- Pull the bean containers out and take off the lids.
- Fill the bean containers with roasted coffee beans.
- Put the lids back on the bean containers to seal them.
- Push the bean containers all the way back into the coffee machine. Close the appliance door.

Tip: Make a note of each bean type.

After filling the bean containers, you can now name the bean types.

Naming the bean types

The 3 bean containers are shown in the display as follows and are pre-named.

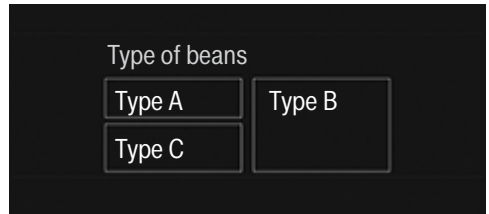

If you rename the bean containers, please note the following:

- It is best to select short names.
- If you are using the same bean types in 2 or 3 bean containers at the same time (for instance because you only use one bean type), make sure you name them in exactly the same way.

Name type of beans for bean container? appears in the display and Type A is highlighted in orange.

- Touch Yes.

The editor will open in the display.

- Enter the name you want for the bean container.
- Touch Save.
- Now name the other 2 bean containers.

<Type XY> Allocate "" will appear in the title bar of the display.

Assigning bean types

Assign the individual bean types to the coffee drinks you would like.

- Select the drinks that are to be prepared with this bean type.

The selected drinks are marked in orange.

- Confirm with *OK*.

Before using for the first time

Now it is time to assign the next bean type. The coffee drinks that have not yet been assigned are displayed.

- Select the drinks that are to be prepared with this bean type.
- Confirm with *OK*.

Any remaining drinks that have not been selected will be assigned to the third bean type.

You have set up the bean system and you can now prepare drinks.

Tip: Touch *All drinks* to select all the drinks. You can then deselect the drinks you do not want.

If you do not assign the bean containers to the drinks, you will be asked what bean type you want to use for the coffee as you make it.

To ensure that any coffee residues from the factory testing process are removed from the brewing system, please throw away the first 2 cups of coffee when using the coffee machine for the first time.

Coffee or espresso can be made from whole roasted coffee beans which are freshly ground for each portion. Your coffee machine has a bean system with 3 bean containers which can be filled with different types of beans or even just one type. You can allocate bean types to individual coffee drinks however you like. Alternatively, you can create your own user profiles that do not have the same bean types allocated to the coffee drinks as the Miele profiles.

 Risk of damage to the grinder due to incorrect operation.

The coffee machine will be damaged if the bean container is filled with unsuitable substances such as liquids, ground coffee or coffee beans treated with sugar, caramel or similar. In addition, green (unroasted) coffee beans or mixtures of coffee beans which contain green coffee beans can damage the grinder. Green coffee beans are very hard and still contain residual moisture. These can damage the coffee machine grinder as soon as grinding begins.

Only put roasted coffee beans in the bean container.

If decaffeinated coffee beans are used after dispensing a drink with caffeinated beans, there may still be residues from the caffeinated beans in the grinder or brew chamber.

Please be aware that minimal residues of caffeinated beans may be present in the next drink that you make.

Changing bean system settings (Type of beans)

The drinks menu is displayed.

- Touch the ↶ sensor control.
- Select Settings.
- Select Type of beans.

The schematic representation of the bean containers is displayed.

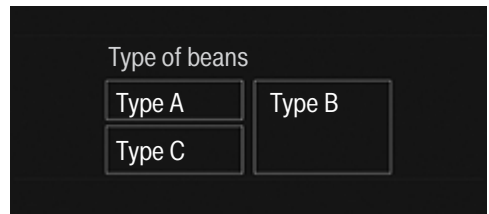

- Select a bean type.

You can now change the name of the bean type or how it is assigned.

Tip: If you want to assign another bean type to a coffee drink, you can also do this under “Change parameters” (see “Parameters – Bean types”).

Renaming the bean types

If you rename the bean types, please note the following:

- It is best to select short names.
- If you are using the same bean types in 2 or 3 bean containers at the same time (for instance because you only use one bean type), make sure you name them in exactly the same way.

- Touch Change name.

The editor will open in the display.

- Enter the name you want.
- Touch Save.

Bean system

If you switch from having identical names to having different names, you will then need to assign coffee drinks to the newly named bean type.

Changing how the bean containers are assigned

If you have created extra user profiles for coffee drinks in addition to the standard Miele profile, the bean types can be individually assigned to the drinks in each profile.

- Touch **Change allocation**.

If you have set up 1 or more profiles and at least 1 coffee drink, first select the profile.

- Select the profile for which you want to assign the bean types.

All coffee drinks will be listed. The already assigned drinks will be highlighted in orange.

- Change the assignment as required.
- Confirm with *OK*.

Tip: Touch **All drinks** to select all the drinks. You can then deselect the ones you do not want.

If you do not assign a bean type, you will be asked what bean type you want to use for the coffee as you make it.

Filling the water container

⚠ Risk to health due to contaminated water.

Bacteria can develop in water which has been sitting in the water container for too long and is a risk to your health.

Change the water in the water container **every day**.

⚠ Risk of damage due to incorrect operation.

Unsuitable liquids such as hot or warm water or other liquids can damage the coffee machine.

Bottled mineral water leaves too much limescale in the coffee machine.

Only use cold, fresh tap water to fill the water container.

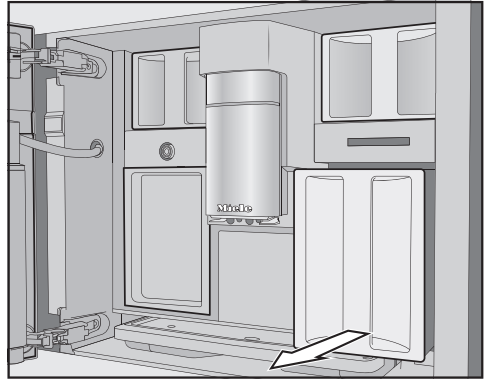

- Pull the water container forwards to remove it.
- Fill the water container with fresh, cold drinking water up to the *max.* mark.
- Push the water container into the appliance.
- Close the appliance door.

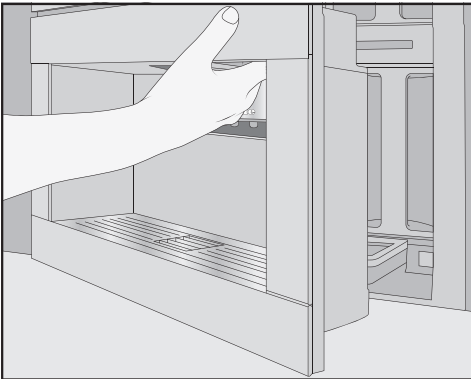

- Open the appliance door.

Switching on and off

Switching the coffee machine on

- Touch the On/Off switch ①.

The coffee machine heats up and rinses the pipework. Hot water will run out of the central spout.

You can now make drinks.

If the coffee machine is already at operating temperature, rinsing will not take place.

Switching the coffee machine off

- Touch the On/Off switch ①.

If a drink has been dispensed, the coffee machine will rinse the coffee pipework automatically before switching off.

While dispensing a drink or during maintenance processes, moisture builds up in the coffee machine. Once a drink has been dispensed or the machine has been switched off, the internal fan will continue to run until the interior is sufficiently dehumidified. You will hear an accompanying noise.

Preparing for an extended period of inactivity

If the coffee machine is not going to be used for a while, e.g. if you are going on holiday, remember to do the following:

- Empty the drip tray, the waste container and the water container.
- Clean all parts thoroughly, including the brew unit and appliance interior.
- Switch the coffee machine off.

 Danger of burning and scalding on the dispensing spouts. The liquids and steam dispensed are very hot and can cause scalding. Keep well away from the area underneath the spouts when hot liquids and steam are being dispensed. Do not touch hot components.

Coffee

Coffee drinks made with and without milk

You can use the coffee machine to prepare the following coffee-based drinks:

- **Ristretto** is a strong, concentrated espresso. It is prepared with the same amount of coffee as for an espresso but with a lot less water.
- **Espresso** is a strong aromatic coffee with a thick hazelnut brown coloured froth – known as the crema – on top. We recommend using espresso-roasted coffee beans to make an espresso.
- **Coffee** differs from espresso by the increased amount of water and the roast of the beans. We recommend using coffee beans of the correct roast to make the coffee.
- **Long coffee** is a coffee with considerably more water.
- **Long black.** This is made with hot water and two shots of espresso.
- **Caffè Americano** consists of espresso and hot water. The espresso is made first, then the hot water is dispensed into the cup.

- **Cappuccino** consists of approx. 2 thirds milk froth and 1 third espresso.
- **Latte macchiato** consists of 1 third each of hot milk, milk froth and espresso.
- **Caffè latte** consists of espresso and hot milk.
- **Cappuccino italiano** has the same proportions of milk froth and espresso as a cappuccino. The difference is that the espresso is added first and then the milk froth.
- **Espresso macchiato** is an espresso with a small amount of milk froth on top.
- **Flat white** is a special variety of cappuccino that contains significantly more espresso than milk froth for an intensive coffee aroma.
- **Café au lait** is a French style of coffee consisting of coffee and milk froth. Café au lait is usually served in a bowl.

Hot milk or milk froth can also be made.

Making drinks

The milk

Cow's milk or alternative plant-based dairy products (e.g. soy milk) containing added sugar can clog up the milk pipe and the rest of the milk pipework. Residues from unsuitable liquids can interfere with milk preparation.

The milk used must not contain any additives.

Dairy milk naturally contains bacteria. If using dairy milk make sure that it has been pasteurised, e.g. pasteurised cow's milk.

As soon as you select a drink containing milk, the machine will start to heat up. The milk will be drawn up into the central spout where it is heated by steam and also frothed for drinks requiring milk froth.

You can prepare hot milk and milk froth using cow's milk or alternative plant-based dairy products. However, the consistency of the milk froth will vary greatly depending on the type of milk used. Not all types of milk are suitable for milk froth.

Tip: Using cold cow's milk (< 10 °C) with a protein content of at least 3 % will produce the perfect milk froth. You can select milk with a fat content according to preference. With whole milk (at least 3.5 % fat), the milk froth will be slightly creamier than with low-fat milk.

Alternative plant-based dairy products – hereafter referred to as “alternative dairy products” – contain different ingredients than cow's milk, for example. Due to natural settling, alternative dairy products tend to thicken. When preparing hot milk or milk froth, this thicker consistency can prevent the alternative dairy products from being drawn into the milk pipework.

Stir alternative dairy products well immediately before preparation.

Do not shake alternative dairy products. Shaking causes foam to form in the packaging and impairs the preparation process.

Tip: Rinse the milk pipework manually immediately after preparation.

Filling and inserting the milk container

Milk is **not** cooled in the milk container.

Milk may spoil if it is left in the milk container for an extended period without being cooled (depending on the type of milk).

In particular, do not leave cow's milk in the milk container for an extended period without cooling it.

Please follow the manufacturer's instructions regarding the shelf life of the milk used.

If you have not made any milk drinks for a while, rinse the milk pipework thoroughly before making the first drink.

Tip: For high-quality milk froth, always use cold milk (< 10 °C).

- If you use alternative dairy products, make sure that you stir the milk well. To ensure the best preparation, alternative dairy products must be stirred and not shaken.
- Fill the milk container with milk up to a maximum of 2 cm below the rim.
- Seal the milk container with the lid.

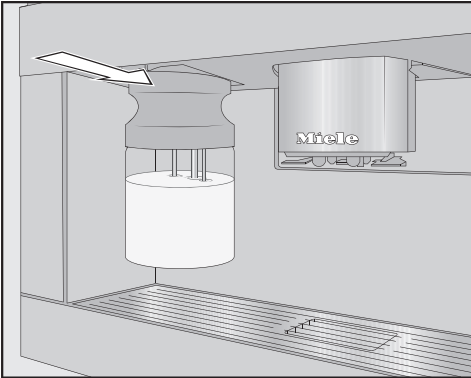

- Push the milk container back into the coffee machine until it clicks into place.



Tip: It is easier to remove the milk container again with both hands.

Making a coffee

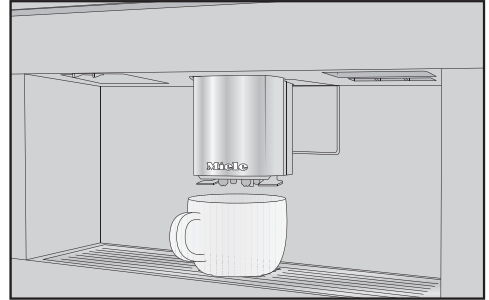

- Place a container underneath the central spout.
- If you want to make a coffee with hot milk or milk froth, prepare the milk container and insert it into the machine.
- Select a coffee drink.

Preparation will begin and the coffee will be dispensed into the container from the central spout.

Cancelling a drink

- Press Stop or Cancel.

DoubleShot

Select the DoubleShot  function if you would like a particularly strong and aromatic coffee. In this case, more coffee beans will be ground and brewed halfway through the brewing process. The shorter extraction time means that fewer unwanted aromas and bitter compounds will be released.

DoubleShot can be activated for all drinks apart from “Ristretto” and “Long black”.

Making drinks

Making a DoubleShot ☉ of coffee

The ☉ symbol will appear while drinks are being made.

- Touch the ☉ symbol immediately before or after you start making a drink.

Dispensing starts and the ☉ symbol is highlighted in orange in the display. 2 portions of coffee beans will be ground and brewed.

Making 2 portions ☐

You can dispense 2 portions of a drink into 1 large cup or into 2 cups at the same time.

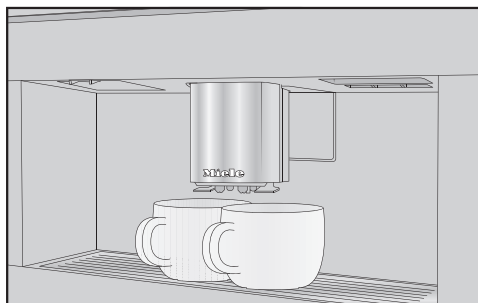

- Place a cup under each of the coffee dispensers in the central spout.
- Touch the ☐ symbol immediately before or after you start making a drink.

Dispensing starts and the ☐ symbol is highlighted in orange in the display. 2 portions of the desired drink will be dispensed.

Coffee pot

You can make several cups of coffee one after the other automatically with the Coffee pot function (maximum of 1 litre).

The drinks menu is displayed.

Tip: Make sure that the bean and water containers have enough beans and water inside them before starting the Coffee pot function.

- Place a sufficiently large container under the central spout.
- Select Coffee pot.

Tip: You will find Coffee pot at the end of the drinks menu.

- Select the number of cups you want (3 to 8).
- Follow the instructions in the display.

Each portion of coffee will be brewed and dispensed individually. You can follow the process in the display.

You can interrupt preparation at any time.

- Touch Cancel.

Tea

The coffee machine is not intended for commercial or scientific purposes. Temperatures given are approximate and can vary according to ambient conditions.

To make tea, you can select from the following options:

- **Japanese tea** is a high-quality green tea which boasts a fine, fresh, "green" taste.
Dispensed temperature: approx. 65 °C, brewing time: approx. 1.5 minutes
- **White tea** is a green tea where only the young buds of the tea plant are used and processed very gently. White tea has a particularly mild taste.
Dispensed temperature: approx. 70 °C, brewing time: approx. 2 minutes

- **Green tea** gets its green colour from the leaves of the tea plant. The tea leaves are either roasted or steamed depending on the region. Green tea can be infused multiple times.
Dispensed temperature:
approx. 80 °C, brewing time:
approx. 2.5 minutes
- **Black tea** gets its dark colour and characteristic taste from the fermentation of tea leaves. Black tea can be enjoyed with a little lemon or milk.
Dispensed temperature:
approx. 97 °C, brewing time:
approx. 3 minutes
- **Chai latte** has its origins in traditional Ayurveda medicine as a black tea with typically Indian spices and milk. The milk mellows the spices and tops off the flavour experience.
Dispensed temperature:
approx. 97 °C, brewing time:
approx. 3 minutes
- **Herbal tea** is an aromatic infusion drink made up of dried leaves or fresh parts of plants.
Dispensed temperature:
approx. 97 °C, brewing time:
approx. 8 minutes
- **Fruit tea** is made from dried pieces of fruit and/or parts of plants, e.g. rose hip. The taste of the drink varies according to which plants are used and how they are blended. Lots of fruit teas are also flavoured.
Dispensed temperature:
approx. 97 °C, brewing time:
approx. 8 minutes

The type of tea determines the preset temperature.
The respective dispensing temperatures are the ones that Miele recommends for making the types of tea concerned.

You can adjust the dispensing temperatures used for the individual teas by customising the brewing temperature (see “Parameters – Brewing temperature”). A temperature increment of approximately 2 °C makes a noticeable difference.

Whether you use loose tea leaves, blended tea or tea bags depends on your own personal preference.

Follow the instructions for making tea on the tea packaging.

The amount of tea required varies from one type of tea to another. Always follow the recommendations of the manufacturer on the packaging or of the retailer. You can adjust the amount of water according to the type of tea and the size of the cup (see “Portion size”).

Making tea

The drinks menu is displayed.

- Pour loose tea into a tea filter or similar, or take a tea bag from the packet.
- Place the tea filter or tea bag into the tea cup.
- Place the tea cup under the central spout.
- Select the type of tea from the display.

Hot water will be dispensed into the cup.

Making drinks

If TeaTimer | Automatic has been selected, the minute minder for the brewing time will start running once the water has been dispensed.

Alternatively, you can also start the TeaTimer function manually at this point.

Starting the TeaTimer manually

- Prepare a cup of tea.
- Touch TeaTimer.

The editor will open with a suggested time.

- Change the brewing time if necessary.
- Confirm with *OK*.

After the brewing time has elapsed, a buzzer will sound and the ⏰ symbol will flash.

- Remove the tea filter or tea bag when the desired brewing time has elapsed.

Teapot

The Teapot function allows you to make a large quantity of tea (maximum of 1 litre). The type of tea selected determines the preset temperature.

The drinks menu is displayed.

Tip: Make sure that the water container has enough water inside it before you start making a pot of tea.

- Place a sufficiently large container under the central spout.
- Select the teapot option you want.
- Select the number of cups you want (3 to 8).

You can interrupt preparation at any time.

- Touch *Cancel*.

Dispensing warm or hot water

You can choose between the following options:

- Hot water at approx. 90 °C
- Warm water at approx. 65 °C

The drinks menu is displayed.

- Place a suitable container underneath the central spout.
- Choose between warm or hot water.

Dispensing will start.

Changing the portion size

The drinks menu is displayed.

- Place the desired cup under the central spout.
- Touch the drink you want and keep your finger on it until the context menu opens.
- Touch *Portion size*.

The drink will now be made. *Save* will appear in the display as soon as the minimum dispensing amount is reached.

- When the cup is filled to the level you want, touch *Save*.

If the maximum amount is reached, preparation stops and the maximum possible amount is saved.

If you want to change the portion size for coffee drinks made with milk or hot water, the ingredients which make up the drink will be saved one after the other while the drink is being made.

The programmed mix of ingredients and portion size will now be dispensed every time that particular drink is selected.

In Expert mode, you can allocate a bean type temporarily and change the portion size while the drink is being made. The setting will **not** be saved and will only apply for the current drink.

Switching Expert mode on and off

Expert mode is located in the pull-down menu at the top edge of the screen.

- Touch the top edge of the screen in the middle and drag down with your finger to open the Expert mode.

The schematic representation of the bean containers is displayed.

- Touch Expert mode.

Expert mode is active when Expert mode is highlighted in orange.

- To exit the pull-down menu, drag the menu window back up to the top or touch an area of the screen outside of the pull-down menu.

Expert mode: assigning bean containers

- Touch the top edge of the screen and open the Expert mode pull-down menu.
- Now select the bean container containing the beans you want to use for the current drink.
- To close the menu window, drag it back up to the top.
- If necessary, switch to the drinks menu.
- Now start making the drink.

Expert mode: changing the portion size

The drinks menu is displayed.

If you select DoubleShot ☉ or 2 portions ☐, Expert mode cannot be used to change the portion size.

- Select a drink.

The preparation process will start. You can adjust the portion size while it is being dispensed, e.g. individually change the amount of hot milk, milk froth and espresso for a latte macchiato.

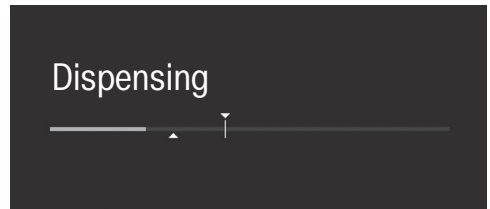

- Touch the bar and adjust the controller (small triangle) as required.

Degree of grinding

The degree of grinding determines the contact time between the ground coffee and the water, known as the extraction time. Only when the ideal degree of grinding is selected can the machine dispense a perfect cup of coffee with a fine, hazelnut brown crema.

Identifying the ideal degree of grinding

There are various ways to tell whether the degree of grinding is set correctly.

The degree of grinding is **too coarse** if the coffee or espresso is watery and tastes acidic. The crema is very pale.

The degree of grinding is **too fine** if the coffee or espresso tastes too bitter and the crema is dark brown.

Adjusting the degree of grinding

If the degree of grinding is adjusted by more than one level, the grinder may be damaged.

Only ever adjust the degree of grinding one level at a time.

Each time you adjust the setting, start making a new drink so that the beans are ground. You can then adjust the degree of grinding by one setting again.

The slide control for adjusting the degree of grinding is located on the top left behind the water container.

- Open the appliance door.
- Remove the water container.

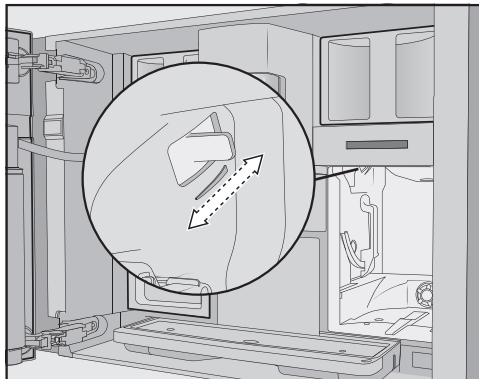

- Push the slide control **exactly 1 setting** forwards (for finer grinding) or one setting backwards (for coarser grinding).

The degree of grinding you select will be used for all coffee drinks and bean types.

- Put the water container back in place.
- Close the appliance door.
- Make one cup of coffee.

Adjust the degree of grinding again, if required.

The grinder will naturally wear out slightly over time. Set the grinder to a finer degree of grinding if necessary.

Type of beans

You can display which type of bean is currently being used for this coffee drink or change which bean container is allocated to it.

Quantity of coffee

The coffee machine can grind and brew 7.5–12.5 g of coffee beans per cup. The greater the quantity of ground coffee, the stronger the drink.

The quantity of coffee is **too low** if the espresso or coffee lacks body.

Increase the quantity of coffee to brew more ground coffee.

The quantity of coffee is **too high** if the espresso or coffee tastes bitter.

Decrease the quantity of coffee to brew less ground coffee.

Pre-brewing the ground coffee

When the pre-brewing function is turned on, the ground coffee is first moistened with a little hot water. The ground coffee swells a little. The remaining amount of water is then pressed through the moistened coffee grounds shortly after. If your coffee tastes too bland and you want to add some spice and richness, try the “Pre-brewing” function. Depending on the type of coffee used, pre-brewing can intensify the taste.

You can set a short or long duration for pre-brewing or turn the “Pre-brewing” function off completely.

Tip: We particularly recommend using the “Pre-brewing” function to make coffee.

Brewing temperature

The brewing temperature must be adapted to the beans you are using and how they are roasted. It also varies depending on whether you are making espresso or coffee.

Some bean types are sensitive to high brewing temperatures, resulting in an impaired taste. If your coffee tastes bitter, the brewing temperature you have selected might be too high.

Espresso is usually brewed at higher temperatures.

You can also adjust the brewing temperature for making tea and dispensing warm and hot water.

Portion size

You can adjust the amount of water for all coffee drinks, hot water and types of tea.

The strength of the coffee is determined by the ratio between the amount of ground coffee and water. If the coffee is brewed with more water but with the same quantity of coffee, the coffee will taste milder and thinner. If you reduce the amount of water, you will get a stronger and more powerful coffee.

If you significantly increase or decrease the portion size and therefore the amount of water for a coffee, you should adjust the quantity of coffee accordingly.

For coffee drinks with milk, you can also set the proportions of milk and milk froth to suit your personal taste. You can also set the portion sizes for hot milk and milk froth separately.

Parameters

The changed portion size is always saved in the current profile. The name of the current profile is shown in the top left of the display.

If the water container becomes empty whilst making a drink, the coffee machine will stop programming the portion size. The portion size will **not** be saved.

- Touch the drink you want and keep your finger on it until the context menu opens.
- Select **Reset** and confirm with **Yes**.

The portion size and parameters are reset to their factory default settings. The allocated bean type remains stored.

Displaying and changing parameters

You can individually adjust the following parameters for each drink:

- Type of beans
- Amount of coffee
- Brew temperature
- Pre-brewing

You can adjust the brewing temperature for making tea and dispensing warm and hot water.

The drinks menu is displayed.

- Touch the name of the drink you want and keep your finger on it until the associated context menu appears.

- Select **Parameters**.

The **Parameters** menu is displayed.

- Select the parameter you want.

The current setting is displayed.

- Change the setting as required.

Resetting drinks

You can reset portion sizes and parameters to their factory default settings for individual drinks or for all drinks.

The drinks menu is displayed.

In addition to the Miele drinks menu (Miele profile), you can create individual profiles to cater for different tastes and preferences.

Within the profile, you can adjust the portion sizes and parameters individually for all drinks.

The name of the current profile is shown in the top left of the display.

Creating a profile

The drinks menu is displayed.

- Touch Profiles.

The Profiles menu opens.

- Touch Create profile.

The editor will open in the display.

- Enter the name you want.
- Touch Save.

The profile has been created. You can now create drinks (see “Profiles: creating and editing drinks”).

Editing profiles

Once you have created a profile, you can rename, delete or move profiles using the context menu.

The drinks menu is displayed.

- Touch Profiles.

The Profiles menu opens.

- To do this, touch the profile name you want to edit and keep your finger on it until the context menu appears.
- Edit the entry as required.

Setting when the profile should change

The drinks menu is displayed.

- Touch Profiles.

The Profiles menu opens.

- To do this, touch the profile name you want to edit and keep your finger on it until the context menu appears.
- Select the option you want.

You can choose between the following options:

- **Manual:** The selected profile will remain active until you select another one.
- **After each use:** The machine will revert to the Miele profile whenever a drink is dispensed.

Profiles: creating and editing drinks

You can save frequently made drinks in a profile with your own individual settings (see “Profiles”).

You can also change the names of your drinks and delete any unwanted drinks from your profile. You can save a maximum of 9 drinks in a profile.

Creating a drink

You can create new drinks based on existing drinks.

The drinks menu is displayed.

- Touch Profiles.

The Profiles menu opens.

- Select the profile you want.

The name of the profile is shown in the top left of the display.

- Touch Create drink.

- Now select a drink.

- Change the portion size or drink parameters to create the drink you want.

Preparation will begin and you can save the portions of each component as desired.

- Enter a name for the new drink and touch Save.

The newly created drink will appear in the profile.

Renaming, moving or deleting an entry

Once you have created some drinks, you can edit these entries in the context menu.

The desired profile with the newly created drinks will appear in the display.

- Touch the name of the drink and keep your finger on it until the context menu appears.
- Edit the entry as required.

You can display drinks you make frequently, drinks from profiles and maintenance programmes in the MyMiele screen.

Tip: You can also set menu options that you have entered in MyMiele as your start screen (see “Settings – Start screen”).

The main menu is displayed.

- Touch MyMiele.

You can now configure MyMiele.

MyMiele: adding an entry

- Touch Add entry.

You can now add entries from the following menus:

- Drinks
- Profiles
- Maintenance

- Select an entry.
- Confirm the message with *OK*.

A box containing the selected option will appear. This also shows which menu it comes from.

MyMiele: deleting or moving an entry

Once you have created some entries, you can move or delete them via the context menu in the MyMiele screen.

- To do this, touch the entry you want and keep your finger on it until the context menu appears.
- Move or delete the entry as required.

MobileStart

With MobileStart  you can, for example, start making a drink via the Miele app.

You will only be able to use MobileStart if Miele@home has been set up for your coffee machine.

 **Danger of burning and scalding on the dispensing spouts.**
If liquids or steam are dispensed while the machine is unsupervised, persons may burn themselves if they place body parts under the central spout or touch hot components.
Ensure that no one, especially children, can be harmed if the machine is operated without supervision.

Automatic cleaning and descaling will not start if MobileStart  is activated. The pipework is not pre-warmed when the machine is switched on either so that the cup under the central spout is not filled with rinse water.

Milk is not cooled in the milk container. If you want to start making a drink with milk using the app, make sure that the milk is sufficiently cold (< 10 °C).

If the coffee machine is being operated manually, it cannot be operated via the app. Operation on the appliance takes precedence.

To start making drinks remotely, MobileStart  must be activated. Make sure that the coffee machine is ready to use, for example check that the water container is sufficiently filled. Place a sufficiently large, empty cup under the central spout.

MobileStart will be deactivated after 24 hours.

If you are making a drink with MobileStart , you will be notified of drink dispensing with acoustic and optical signals. These signals cannot be changed or switched off.

Switching MobileStart on and off

If you want to use MobileStart , the Remote control option must be switched on.

The drinks menu is displayed.

■ Touch the  sensor.

The  sensor lights up. You can now start making a drink via the app. Follow the prompts for doing this.

You can personalise your coffee machine by adapting the factory default settings to suit your requirements.

Displaying and changing settings

The drinks menu is displayed.

- Touch the ↶ sensor.
- Select Settings.
- Select the option you want to change.
- Change the setting.

If necessary, confirm your choice with *OK*.

Some settings which can be found in the Settings menu are described in their separate sections in the operating instructions.

Language

You can select the language (and location variant of that language) for all display text.

Tip: If you select the wrong language by mistake, you can find the “Language” option again via the  symbol.

Time

Display (Clock display)

Select how you want the time of day to show in the display when the coffee machine is switched off:

- **On:** The time is always visible in the display.
- **Off:** The time is not visible in the display.
- **Night dimming:** To save energy, the time is only displayed between 5 am and 11 pm.

Clock type

The time of day can be displayed in **analogue** (clock face) or **digital** (hours: minutes plus date) format when the coffee machine is switched off.

Clock format

- 24-hour display (24 h)
- 12-hour display (12 h (am/pm))

Setting

Set the hours and the minutes.

Tip: There is a shortcut for setting the time without having to access the Settings menu: simply touch the time of day on the top right of the display.

If the coffee machine has been connected to a WiFi network and is signed into the Miele app, the time will be synchronised based on the location setting in the Miele app.

Date

Set the date.

The date will only appear if the following setting is selected: Time | Clock type | Digital.

Start screen

You can choose which screen appears when the coffee machine is switched on. For instance, you can use MyMiele to display a personalised menu (see “MyMiele”).

The new start screen will appear when the coffee machine is next switched on.

The drinks menu is set as the start screen by default.

Settings

Timer

Appliance timer

The coffee machine has 3 timers:

- Switch on at
- Switch off at
- Switch off after

You can allocate the individual timer functions to different days of the week. For example, you can set different times for the timer at the weekend (Sat. and Sun.) and/or from Monday to Friday (Monday-Friday). Alternatively, you can select Daily to use the same timer settings every day.

Tip: If you are unable to set the timers because the screen is greyed out, touch On to enable timer adjustment.

To save the timer functions and activate the timer, select Accept all.

To deactivate the timer, select Switch all off.

Delete allows you to deactivate the timers individually. In this case, the following will appear in the display: -- --.

Switch on at (On at)

The coffee machine switches on at a particular time, e.g. in the morning for breakfast.

The coffee machine will **not** switch on at the required time if you have activated the system lock. The timer settings are deactivated.

Once the coffee machine has come on automatically **three times** at the set time without any drinks being dispensed, it will stop switching on automatically. This prevents the coffee machine from switching itself on unnecessarily, for example, whilst you

are away on holiday.

The programmed times will, however, remain in the memory and will be reactivated when the machine is next switched back on manually.

If you have set the time of day display while the appliance is switched off (Display | On or Night dimming) and the time is being displayed in digital format (Clock type | Digital), the  symbol and the desired switching-on time will appear in the display 23:59 hours beforehand.

Switch off at (Off at)

The coffee machine switches off at a particular time.

Switch off after (Switch off after)

The coffee machine switches off after a particular length of time if no sensors have been pressed.

By default, the coffee machine switches off after 20 minutes.

You can change this to another time of between 20 minutes and 9 hours.

If you deactivate the timer functions by selecting Switch all off, the coffee machine will switch off after the last set time.

Maintenance timer

Use the Maintenance Timer to select any start time you like for the automatic maintenance programmes (see “Automatic cleaning and descaling”, “Maintenance Timer” section).

TeaTimer

You can use the TeaTimer function to start a minute minder when making tea. There is a preset brewing time for the

type of tea selected. You can adjust the preset brewing time (up to a maximum of 14:59 minutes).

There are 2 TeaTimer functions available and they can be started independently of one another.

You can choose between the following options:

- **Automatic:** The TeaTimer starts automatically once the water has been dispensed.
- **Manual:** Once the water has been dispensed, you have the option of starting the TeaTimer.

The TeaTimer is shown together with the associated brewing time in the top right of the display.

While the brewing time is counting down, you can continue to use the coffee machine as normal. After the brewing time has elapsed, a buzzer will sound and the ⌚ symbol will flash.

Volume

You can set the volume of the buzzer and keypad tones using the bar chart.

Display

Brightness

The display brightness is adjusted via a bar with seven segments.

Colour scheme

Choose between a light or dark colour scheme for the display.

QuickTouch

Use this setting to define whether the ☀ sensor and movement sensor should respond when the coffee

machine is off and the time is being shown in the display (Time | Display | On or Night dimming).

Lighting

Use the segment bar to set the lighting intensity.

You can use the ☀ sensor to switch the lighting on or off at any time, provided that the coffee machine is switched on.

If the coffee machine is switched off, you can still switch the lighting on or off whenever you like but you will need to select the following settings first:

- Time | Display | On or Night dimming (time of day is displayed)
- Display | QuickTouch | On

Info (display information)

In the Info menu option, you can display the number of drinks dispensed and the fill levels of the cartridges (provided that they have been fitted).

Altitude

If the coffee machine is installed at high altitudes, the lower air pressure will cause the water to boil at a correspondingly lower temperature. You can set the local altitude to ensure the ideal drink preparation temperatures.

Performance mode

You can select the appropriate performance mode for how you use your machine. Eco mode is set by default.

Settings

Eco mode

Eco mode is an energy-saving mode. The system does not heat up until someone starts making a drink.

Barista mode

This performance mode has been optimised for unadulterated coffee enjoyment. Users can enjoy coffee-based drinks without any delay as the coffee machine remains heated to the brewing temperature. This mode consumes more energy than Eco mode.

Latte mode

This performance mode has been optimised for preparing milk. Milk-based drinks can be prepared within a much shorter space of time. This mode consumes more energy than Eco mode and Barista mode.

Party mode

This performance mode has been configured for the **occasional** intensive use of the coffee machine, e.g. for family get-togethers.

Before switching off the coffee machine, empty the drip tray and fill the water container so that any pending maintenance programmes are able to run.

Clean the coffee machine thoroughly after intensive use, particularly the milk pipework. It may be necessary to descale the coffee machine manually and degrease the brew unit.

Please note the following information about Party mode:

- The general pipework is rinsed much less frequently or not at all. The milk pipework is not rinsed until around 1 hour after milk was last dispensed.
- Cleaning status messages or cleaning prompts are suppressed and delayed until the machine is next switched on.
- The Off at and Switch off after timers are deactivated. The coffee machine switches off 6 hours after the last sensor was pressed.
- The cup light remains permanently switched on at the maximum brightness level for as long as the coffee machine stays switched on.

Water hardness

Programme the coffee machine to the water hardness level of your area so that it functions correctly and does not get damaged.

Contact your local water supplier to find out your local water hardness range if necessary.

If you are using bottled drinking water, e.g. mineral water, select settings according to the calcium content. The calcium content is specified on the label of the bottle in mg/l Ca²⁺ or ppm (mg Ca²⁺/l).

Do not use carbonated water.

The hardness level is set to 21 °dH by default.

Water hardness		Calcium content mg/l Ca ²⁺ or ppm (mg Ca ²⁺ /l)	Setting s
°dH	mmol/l		
1	0.2	7	1
2	0.4	14	2
3	0.5	21	3

Water hardness		Calcium content mg/l Ca ²⁺ or ppm (mg Ca ²⁺ /l)	Setting s
°dH	mmol/l		
4	0.7	29	4
5	0.9	36	5
6	1.1	43	6
7	1.3	50	7
8	1.4	57	8
9	1.6	64	9
10	1.8	71	10
11	2.0	79	11
12	2.1	86	12
13	2.3	93	13
14	2.5	100	14
15	2.7	107	15
16	2.9	114	16
17	3.0	121	17
18	3.2	129	18
19	3.4	136	19
20	3.6	143	20
21	3.8	150	21
22	3.9	157	22
23	4.1	164	23
24	4.3	171	24
25	4.5	179	25
26	4.6	186	26
27	4.8	193	27
28	5.0	200	28
29	5.2	207	29
30	5.4	214	30
31	5.5	221	31
32	5.7	229	32
33	5.9	236	33
34	6.1	243	34

Water hardness		Calcium content mg/l Ca ²⁺ or ppm (mg Ca ²⁺ /l)	Setting s
°dH	mmol/l		
35	6.3	250	35
36	6.4	257	36
37–45	6.6–8.0	258–321	37–45
46–60	8.2–10.7	322–429	46–60
61–70	10.9–12.5	430–500	61–70

Tip: If your water hardness is >21 °dH (3.8 mmol/l), we recommend using bottled drinking water instead (< 150 mg/l Ca²⁺). This will mean your coffee machine will need to be descaled less often and there will be less impact on the environment because less descaler will be used.

Movement sensor



The movement sensor detects when you approach the touch display with your hand or body. You can activate the following functions individually:

- **Switch the light on:** You can decide whether the light should come on when the coffee machine is on or off.
- **Acknowledge buzzer:** Buzzer sounds are suppressed, e.g. in the event of the message Fill and replace the water container.
- **Switch the appliance on:** The start screen is displayed.

The movement sensor is deactivated by default.

Settings

If you want the movement sensor to respond even when the coffee machine is switched off, activate QuickTouch as well (Display | QuickTouch | On).

When the system lock is activated, the movement sensor functions are deactivated.

System lock

You can lock the coffee machine to prevent it being used without your knowledge, by children, for example.

When the system lock is activated, the settings for the On at timer and the movement sensor are deactivated. The coffee machine will **not** switch on at the set time and/or will not respond to movement when someone approaches it.

Temporarily deactivating the system lock

- Touch the display for 6 seconds.

The system lock is reactivated when the coffee machine is next switched off.

Miele@home

The following options may appear under Miele@home:

- **Set up**: This option only appears if the coffee machine has never been connected to a WiFi network or if the network configuration has been reset.
- **Deactivate*/Activate***: The settings for the WiFi network are retained, but the network is switched on or off.
- **Connection status***: Information about the WiFi connection is displayed. The symbols indicate the strength of the connection.

- **Set up again***: The settings for the current WiFi network will be reset. The WiFi connection will be set up from scratch.
- **Reset***: The WiFi is switched off and the settings for the current WiFi network will be reset.

The network configuration should be reset whenever the coffee machine is being disposed of or sold, or if a used coffee machine is being put into operation. This is the only way to ensure that all personal data has been removed and the previous owner will no longer be able to access the coffee machine.

- * This menu option appears if Miele@home has been set up and the coffee machine has – where applicable – been connected to a WiFi network.

Remote control

The remote control option appears when the coffee machine is connected to a WiFi network.

You can change the coffee machine settings, for example, in the Miele app when remote control is switched on. To start making a drink via the app, MobileStart must be activated as well.

The remote control function is switched on by default.

SuperVision

The SuperVision option appears when the coffee machine is connected to a WiFi network.

SuperVision allows you to monitor other household appliances in the Miele@home system.

SuperVision display

When SuperVision is on (SuperVision | On), the  symbol appears in the display.

Display in Standby mode

SuperVision is also available in Standby mode if the time display function is switched on (Settings | Time | Display | On or Night dimming).

Appliance list

All household appliances signed in to the Miele@home system are listed.

You can switch SuperVision on or off for the signed-in household appliances. If you switch off SuperVision for a particular household appliance, any faults that occur in relation to this appliance will still be displayed.

You can also switch the buzzer on or off for the listed household appliances.

RemoteUpdate

The RemoteUpdate menu option is only displayed and can only be selected if the requirements for using Miele@home have been met.

The RemoteUpdate function allows the software on your coffee machine to be updated. If an update is available for your coffee machine, it will automatically download it. Updates will not be installed automatically. They must be initiated manually.

If you do not install an update, you can continue to use your coffee machine in the usual way. However, Miele recommends installing updates.

Activating/deactivating

The RemoteUpdate function is activated by default. Available updates will be downloaded automatically but will only be installed if you initiate installation manually.

Deactivate RemoteUpdate if you do not want any updates to be downloaded automatically.

Running a RemoteUpdate

Information about the content and scope of an update is provided in the Miele app.

A message will appear in your coffee machine display if a software update is available.

You can install the update immediately or postpone this until later. When the coffee machine is switched on again, you will be reminded about the update. Deactivate RemoteUpdate if you do not want to install the update.

The update may take several minutes.

Please note the following information about the RemoteUpdate function:

- You will only receive a message when an update is available.
- Once an update has been installed, it cannot be undone.
- Do not switch the coffee machine off during the update. Otherwise, the update will be aborted and will not be installed.
- Some software updates can only be carried out by the Miele Customer Service Department.

Settings

Software version

The “Software version” menu option is intended for the Miele Customer Service Department. You do not need this information for domestic use.

Legal information

This menu option contains details of the open source licences used.

Showroom programme (demo mode)

Do not activate this function for domestic use.

The Showroom programme | Demo mode function enables the coffee machine to be demonstrated in shops or showrooms. In this mode, the appliance lights up but no drinks can be prepared and no maintenance programmes can be run.

You can activate demo mode without commissioning the appliance for the first time. Switch the coffee machine on and off again. Press the ↵ control for 5 seconds straight away. Demo mode is activated.

Factory defaults

You can reset the coffee machine to its factory default settings.

MyMiele can be reset separately.

The following will **not** be reset:

- The number of drinks dispensed and the machine status (No. of portions until machine needs descaling, ... brew unit needs degreasing)
- Language
- Time and date
- Profiles and their associated drinks (the allocation of bean types to drinks is reset)
- Miele@home

The Maintenance timer is reset to 2:00 h.

 Risk to health due to inadequate cleaning

Heat and moisture inside the coffee machine can cause coffee residues to become mouldy and/or milk residues to go off and pose a risk to health.

Carefully clean the coffee machine regularly.

Overview of cleaning intervals

Recommended frequency	What do I have to clean/maintain?
Daily (at the end of the day)	Milk flask and lid
	Milk valve
	Water container
	Drip tray cover
	Drip tray and waste container
Once a week (more often if heavily soiled)	Central spout
	Cup rim sensor
	Interior cabinet
	Brew unit
	Drip tray
	Appliance front
Once a month	Bean container
	Remove and clean the milk valve
As and when required / after prompt appears in display	Milk pipework (using the cleaning agent for milk pipework)
	Degrease the brew unit (using cleaning tablets)
	Descale the appliance

Cleaning and care

Cleaning by hand or in the dishwasher

The brew unit is **not** dishwasher safe. Clean the brew unit by hand only under warm running water. **Do not use washing-up liquid or any other cleaning agent.**

The following components must be cleaned **by hand only**:

- Central spout stainless steel cover
- Brew unit
- Bean containers and lids

 Risk of damage as a result of excessively high dishwasher temperatures.

Components may be ruined (e.g. may become warped) if washed in a dishwasher at temperatures higher than 55 °C.

For dishwasher-safe components, always select dishwasher programmes with a maximum temperature of 55 °C.

Contact with natural dyes such as those found in carrots, tomatoes and ketchup may discolour the plastic parts in the dishwasher. This discolouration does not affect the stability of the parts.

The following components are **dishwasher safe**:

- Drip tray, lid and waste container
- Drip tray cover
- Central spout (without stainless steel cover)
- Milk flask and lid

- Cup sensor
- Drip tray
- Maintenance container
- Water container

 Danger of burning and scalding on hot components or by hot liquids.

Components can become very hot during operation. Touching hot components can cause burning. The liquids and steam dispensed are very hot and can cause scalding.

Keep well away from the area underneath the spouts when hot liquids and steam are being dispensed.

Always allow the coffee machine to cool down before cleaning it.

Please be aware that water in the drip tray can also be very hot.

 Risk of damage due to moisture ingress.

The steam from a steam cleaning appliance could reach live electrical components and cause a short circuit.

Do not use a steam cleaner to clean the coffee machine.

It is important to clean the machine regularly, as the used coffee grounds will soon go mouldy. Milk residues can go off and can block the milk pipework.

Unsuitable cleaning agents

Contact with unsuitable cleaning agents can alter or discolour the external surfaces. All surfaces are susceptible to scratching. Scratches on glass can in some circumstances lead to breakage.

Remove all cleaning agent residues immediately. To protect the machine and surrounding surfaces from damage, make sure you remove any spillages or splashes of descaling agent immediately.

To avoid damaging the surfaces, do not use:

- Cleaning agents containing soda, ammonia, acids or chlorides
- Solvent-based cleaning agents
- Cleaning agents containing descaling agents (unsuitable for cleaning the front of the machine)
- Stainless steel cleaning agents
- Dishwasher cleaners (unsuitable for cleaning the front of the machine)
- Glass cleaning agents
- Cleaning agents for ceramic hobs
- Oven cleaners
- Abrasive cleaning agents, e.g. powder cleaners and cream cleaners
- Hard, abrasive brushes or sponges, e.g. pot scourers, brushes or sponges which have been previously used with abrasive cleaning agents
- Melamine eraser blocks

- Sharp metal scrapers
- Steel wool or stainless steel wire scourers

Cleaning the drip tray and waste container

 Danger of burning and scalding on hot components or by hot liquids. Components can become very hot during operation. Touching hot components can cause burning. The liquids and steam dispensed are very hot and can cause scalding.

If the pipework has just been rinsed, wait a while before removing the drip tray from the coffee machine.

Please be aware that water in the drip tray can also be very hot. Do not touch hot components.

Clean the drip tray and waste container **every day** to avoid unpleasant smells and mould.

A prompt will appear in the coffee machine's display when the drip tray and/or the waste container is full and needs to be emptied. Empty the drip tray **and** the waste container. The lid does not need to be taken off the drip tray in order to empty it.

Cleaning and care

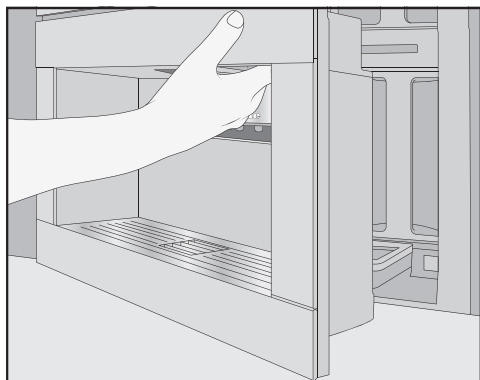

- Open the appliance door.

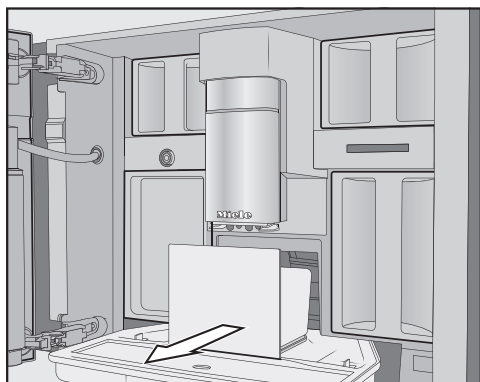

- Remove the drip tray and waste container from the appliance.
- Empty the waste container after removing it from the drip tray.

The waste container may contain a small amount of water from rinsing as well as the leftover coffee grounds.

Taking the drip tray apart

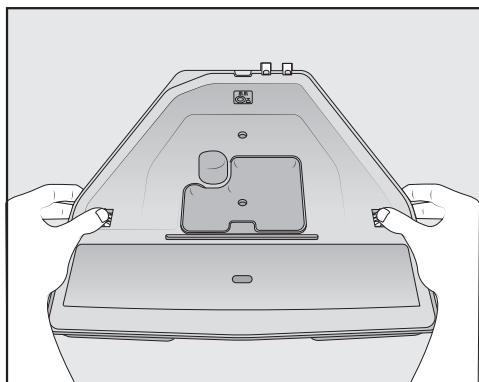

The orange clips are not removable.

- Take the lid off the drip tray as follows: press the orange clips outwards on both sides to release the lid.
- Remove the lid.
- Clean the drip tray, lid and waste container by hand using warm water and a little washing-up liquid.
- Dry all parts.

Tip: To give the drip tray, lid and waste container an extra thorough clean, clean them in the dishwasher from time to time. If the drip tray is heavily soiled, clean it with a brush before placing it in the dishwasher.

- Clean the inside of the coffee machine underneath where the drip tray goes.

Cleaning the contacts on the drip tray

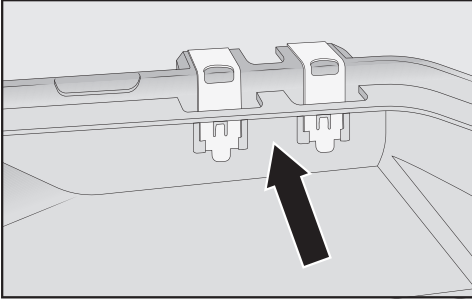

- Clean the contacts (metal discs) and the space between them carefully, e.g. using a brush.
- Dry all parts thoroughly.

The contacts will not be able to detect that the drip tray is full if they are damp or dirty. Check the contacts and the area around them once a week.

Reassembling the drip tray

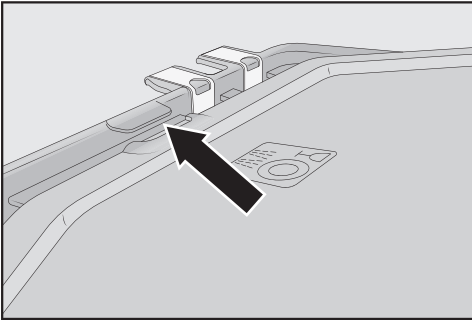

- Attach the drip tray lid as follows: slide the lid under the lug next to the contacts and apply pressure to the lid until the catches at the sides audibly click into place.

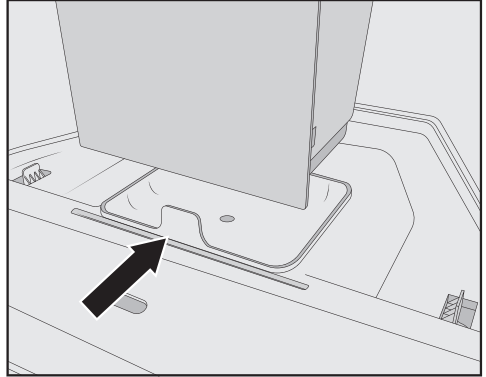

- Place the waste container on the lid.
- Push the drip tray and waste container back into the coffee machine.
- Close the appliance door.

Cleaning the drip tray cover

Clean the drip tray cover on a daily basis.

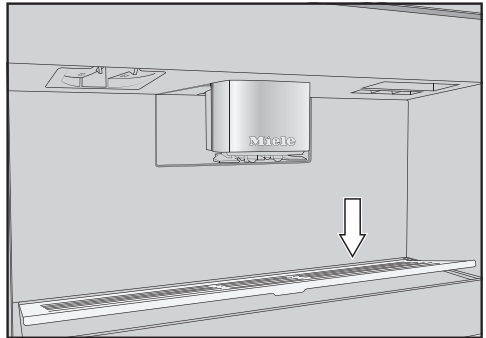

- Remove the drip tray cover as follows: apply pressure to the rear edge so that the cover tips forwards and you can remove it easily.
- Clean the drip tray cover by hand using warm water and a little washing-up liquid.

Cleaning and care

- Dry the drip tray cover.
- Refit the drip tray cover.

Tip: To give the drip tray cover an extra thorough clean, clean it in the dishwasher from time to time.

Cleaning the water container

Clean the water container every day.

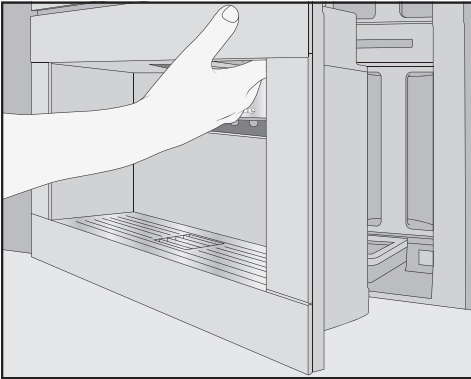

- Open the appliance door.
- Remove the water container.
- Clean the water container by hand with warm water and a little washing-up liquid.
- Rinse the water container with clean water to remove any remaining washing-up liquid.
- Dry the outside of the water container.

Tip: To give the water container an extra thorough clean, clean it in the dishwasher from time to time.

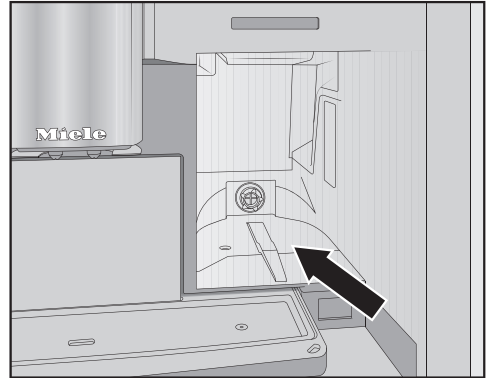

- Clean and dry the surface that the water container sits on.
- Fill the water container with fresh, cold drinking water.
- Push the water container all the way into the coffee machine until you feel resistance.
- Close the appliance door.

Please note that the automatic maintenance programmes will only work if the water container has been adequately filled and correctly fitted in the machine.

Cleaning the central spout

Only ever clean the central spout's stainless steel cover by hand using warm water and a little washing-up liquid.

Clean all parts of the central spout at least once a week.

Removing the central spout

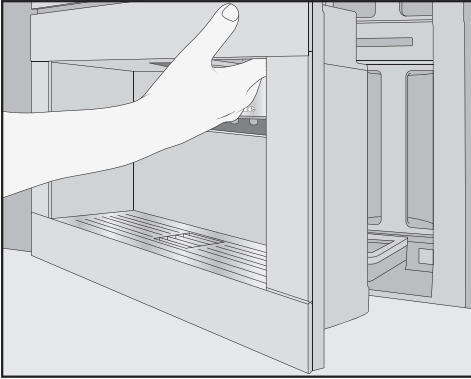

- Open the appliance door.
- Pull the central spout's stainless steel cover forwards to remove it.
- Clean the central spout's stainless steel cover.

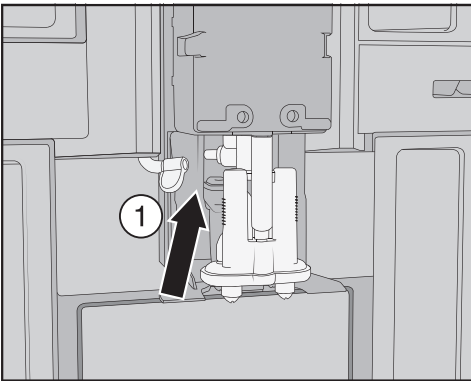

- Detach the milk pipework from the dispensing unit as follows: pull the opening tag ① to the left.

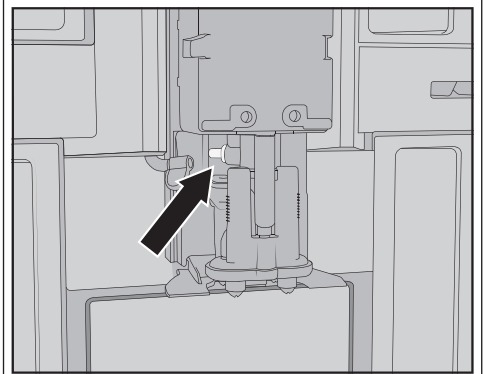

Do **not** remove the milk pipework connecting piece.

If necessary, clean the connecting piece with the cleaning brush.

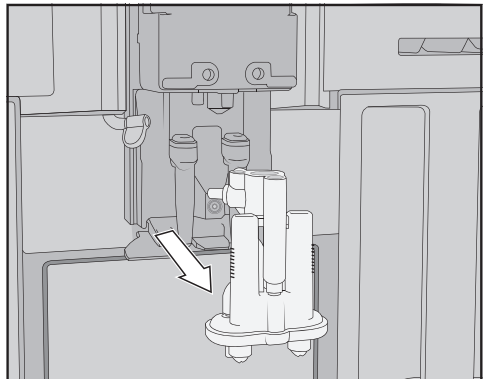

- Grip the dispensing unit by the sides and pull it down to remove it.

Cleaning and care

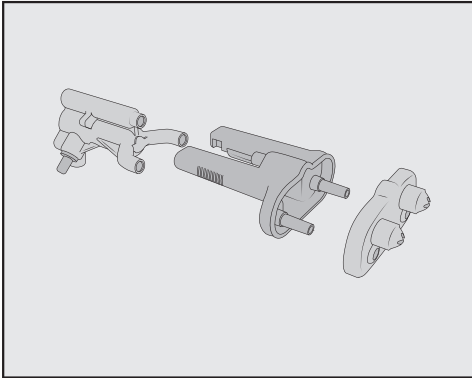

- Take the dispensing unit apart, separating it into 3 components: the Y-piece, the spouts and the holder.

Cleaning the central spout

Only ever clean the central spout's stainless steel cover by hand using warm water and a little washing-up liquid.

- Clean all parts thoroughly by hand.
- Tip:** With the exception of the stainless steel cover, all parts of the central spout should be cleaned in the dishwasher from time to time to give them a thorough clean. This will remove coffee deposits and milk residues effectively.

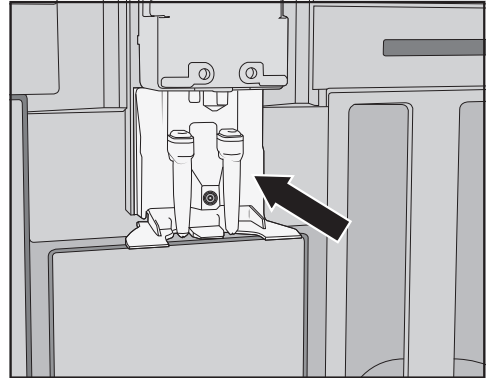

- Clean the area around the central spout with a damp sponge cloth.

Inserting the central spout

The dispensing unit is easier to reassemble if the individual parts are dampened with water first.

Make sure that all parts are tightly connected to one another.

- Fit the dispensing unit back together.
- Press down firmly so that the spouts become securely connected to the holder.

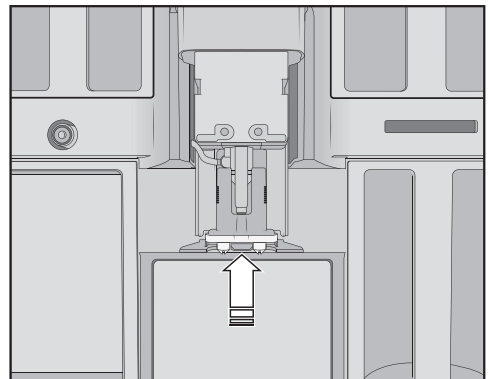

- Slide the dispensing unit into the coffee machine.
- Connect the milk pipework.

- Refit the stainless steel cover.
- Close the appliance door.

Fit cover to central spout will appear in the display.

- Confirm with *OK*.

Cleaning the cup rim sensor

Clean the cup rim sensor at least once a week and more often if heavily soiled.

The cup rim sensor is located under the central spout.

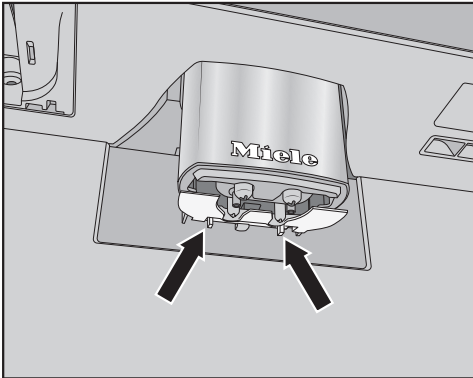

- Press the two latches together (see arrows).

The cup rim sensor is released.

- Clean the cup rim sensor by hand with warm water and a little washing-up liquid.

Tip: To give the cup rim sensor an extra thorough clean, clean it in the dishwasher from time to time.

- To refit the cup rim sensor, press it into the holder on the central spout from below.

Cleaning the milk container with lid

The milk container should be taken apart and cleaned every day after use.

Both the lid and the glass flask can be cleaned in the dishwasher, or by hand using warm water and a little washing-up liquid.

- Remove and empty the milk container.

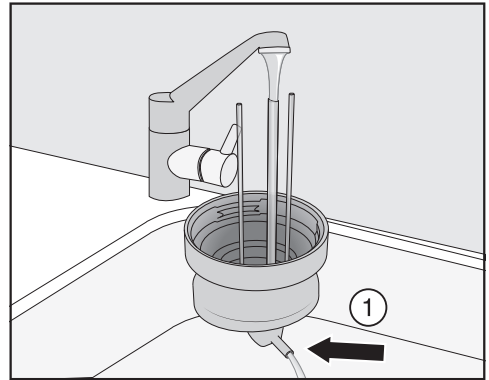

- Rinse the milk pipework in the lid under running water and then place the milk container lid in the dishwasher.
- If no water runs out of the connecting piece ①, clean it with the cleaning brush.
- Clean the glass flask.
- Use a clean cloth to dry all parts, paying particular attention to the threads on the lid and on the glass.
- Reassemble the milk container.

Cleaning and care

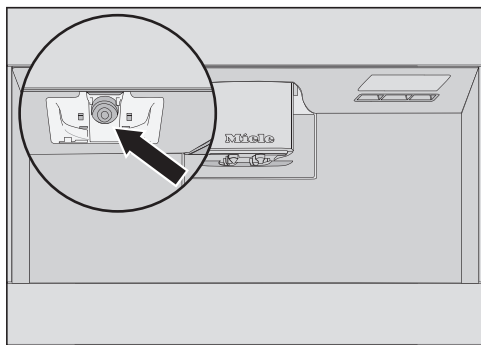

- Use a damp sponge cloth to clean the milk container holder on the coffee machine.

Cleaning the milk valve (daily)

The milk valve seal can be damaged by objects with sharp edges or similar.

Do not use any sharp-edged objects, e.g. knives, to clean the milk valve.

Clean the milk valve every day. If allowed to dry, milk residues can become encrusted on the stainless steel bolt. These crusty deposits are difficult to remove. Therefore, it is important to carry out regular cleaning after preparing milk.

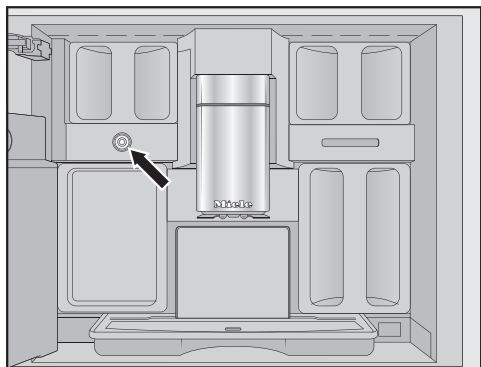

The milk valve is located under the bean container on the left-hand side.

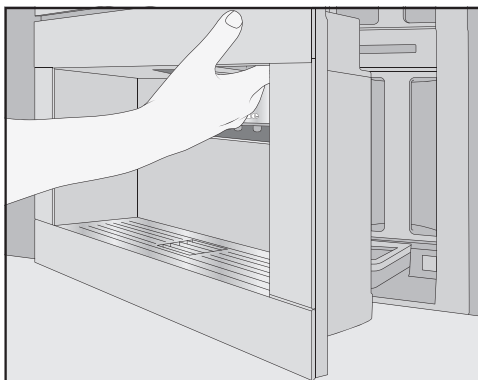

- Open the appliance door.
- Clean the milk valve with a damp sponge cloth/microfibre cloth.
- Close the appliance door.

Removing and cleaning the milk valve (once a month)

Only remove the milk valve when the coffee machine is switched off. Do **not** switch on the coffee machine while the milk valve is removed.

Remove and clean the milk valve at least once a month. If only hot milk is dispensed instead of milk froth or the milk sprays out during dispensing, the milk valve may be blocked. Clean the milk valve more often if necessary.

Removing the milk valve

Only remove the milk valve when the coffee machine is switched off. Do **not** switch on the coffee machine while the milk valve is removed.

- Switch the coffee machine off.

Cleaning and care

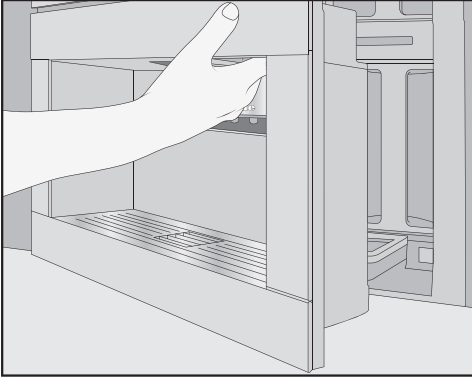

- Open the appliance door.
- Remove the bean container on the left and the maintenance container.
- Remove the central spout's stainless steel cover.

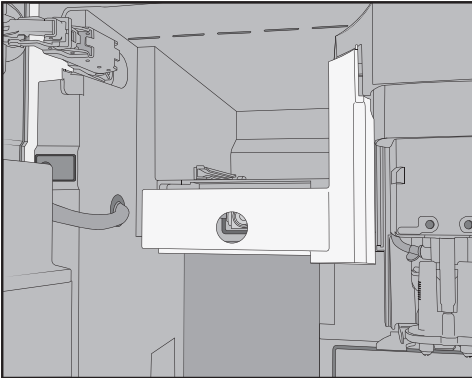

- Remove the milk valve cover. Press on the recessed grip to unlock the cover. On the top right-hand side of the cover, you will find a pin for swivelling the cover out.

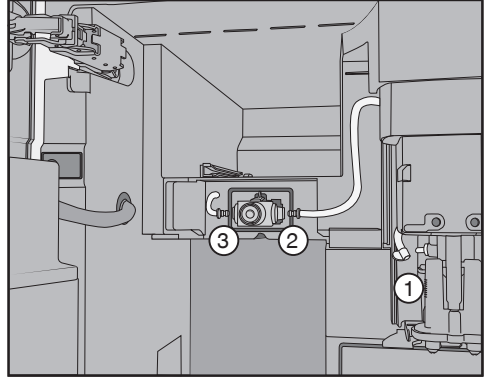

- Detach the milk pipework from the dispensing unit on the central spout ① and from the milk valve silicone seal ② and ③.
- Remove the milk pipework ① connecting the milk valve to the central spout.
- Disconnect the angular moulded hose from the round hose.
- Rinse the hoses thoroughly under running water.

Do **not** remove the connecting pieces from the hoses.

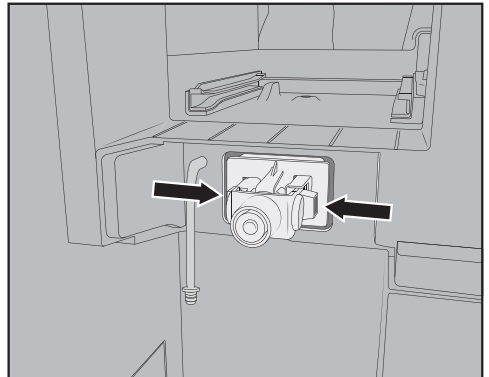

- Press the latches on the left and right-hand sides of the milk valve holder and pull the holder forwards to remove it.

Cleaning and care

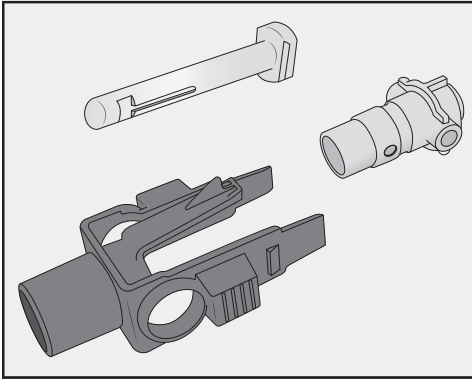

- Take the holder and silicone seal apart.

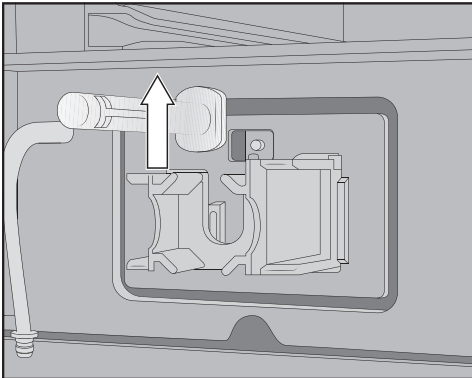

- Pull the stainless steel bolt upwards and out.

Cleaning the milk valve

The milk valve cover is not dishwasher-safe.
The milk valve cover may be damaged if cleaned in the dishwasher.
The milk valve cover should only ever be cleaned **by hand**.

Do **not** switch on the coffee machine while the milk valve is removed.

- Clean all parts of the milk valve by hand.

Tip: With the exception of the cover, all parts of the milk valve should be cleaned in the dishwasher from time to time to give them a thorough clean. If there is any dry milk residue on the front, soak the stainless steel bolt in warm water and a little washing-up liquid.

Inserting the milk valve

Do **not** switch on the coffee machine while the milk valve is removed.

- Insert the stainless steel bolt from above.
- Insert the silicone seal into the milk valve holder.

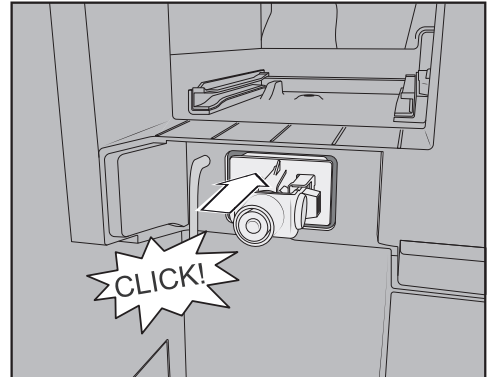

- Insert the holder and silicone seal until they audibly click into place.

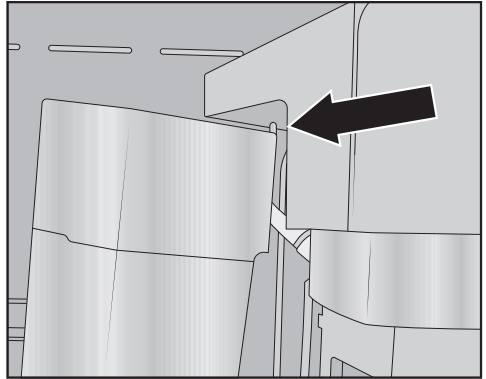
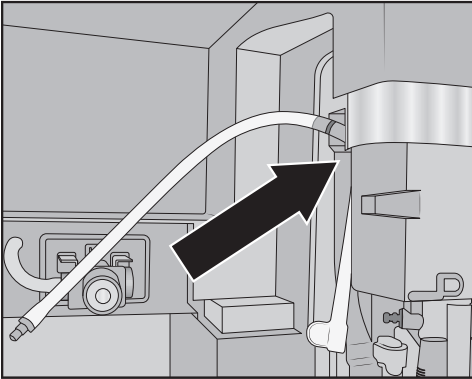

- Connect together the angular moulded hose and longer milk pipework. Start by attaching the moulded hose to the top of the central spout. The black connecting piece should be pointing to the rear.
 - Then, connect the bottom end of the moulded hose to the dispensing unit.
 - Insert the milk pipework into the milk valve on the left and right-hand sides. Push the connecting pieces into the silicone seal as far as they will go.
 - Check that the milk pipework is snug against the housing and that the cover can be easily attached.
- Attach the milk valve cover as follows: insert the pin in the top right-hand corner and swivel the cover backwards until a proper fit is achieved.
 - Push the left-hand bean container and maintenance container back into the coffee machine.
 - Attach the central spout's stainless steel cover.
 - Close the appliance door.

You can now switch the coffee machine back on.

Cleaning the bean containers

-  Risk of damage from incorrect use and cleaning. Immersing the bean containers in liquids can result in malfunctions. If they are taken apart, bits may break off or the mechanism may no longer work properly once they are reassembled.
- Do not disassemble the bean containers.
- Do not immerse the bean containers in liquids, e.g. soapy water.

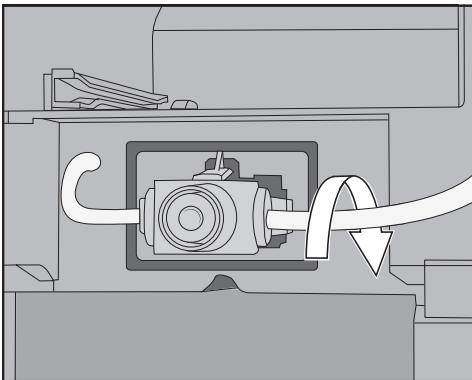

Tip: If necessary, turn the milk pipework towards the back at the connecting piece on the right-hand side.

Cleaning and care

Coffee beans contain oils that can deposit themselves on the walls of the bean containers and hinder the flow of the beans. Therefore, clean the bean containers at least once a month with a soft cloth.

If required, you can clean the lids of the bean containers **by hand** with warm water and a little washing-up liquid. Dry the lids thoroughly before refitting them on the bean containers.

- Open the appliance door.
- Pull the left and right-hand bean containers out of the coffee machine.
- Clean the bean container wells inside the machine.

Tip: Use a vacuum cleaner to remove any coffee residues from the interior.

- Remove the lids and empty the bean containers.

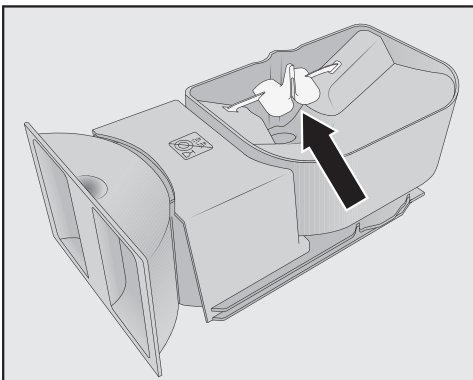

Do not remove the components for improving the flow of the beans (see arrow).

- Clean the bean containers and lids **by hand** using a slightly moist cloth.
- Dry all parts carefully before filling the bean containers with roasted coffee beans again.

- Refit the lids.
- Push the bean containers back into the coffee machine.
- Close the appliance door.

Removing the brew unit and cleaning it by hand

The moving parts of the brew unit are lubricated. Cleaning agents will damage the brew unit.

Only ever clean the brew unit by hand with warm water. **Do not use any cleaning agents.**

Remove and clean the brew unit **once a week**. Also clean the area below the brew unit once a week.

Removing the brew unit

When you have removed the brew unit, do **not** change the position of the handle on the brew unit. Otherwise, the brew unit cannot be reinserted.

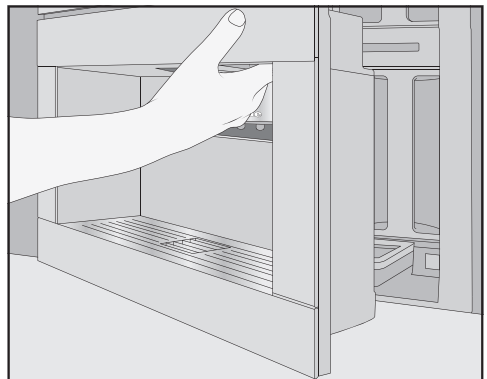

- Open the appliance door.
- Remove the water container.

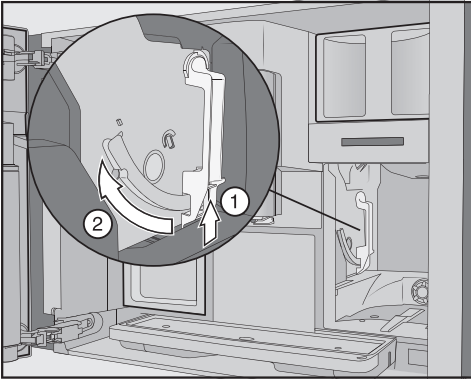

- Press the button under the handle of the brew unit ① and, whilst doing so, turn the handle forwards ②.

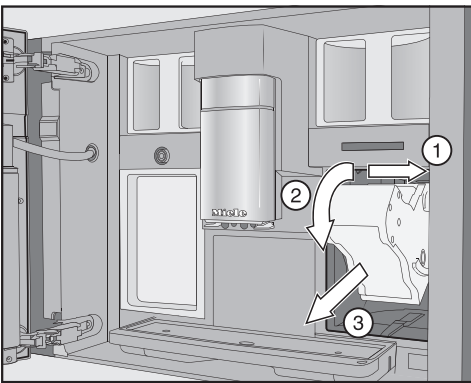

- First, pull the brew unit sideways ① and then slide it out forwards ③. While doing this, tilt the brew unit forwards ②.

If you cannot remove the brew unit or can only do so with difficulty, the brew unit is not in the correct position (see “Problem solving guide”).

Cleaning the brew unit

The moving parts of the brew unit are lubricated. Cleaning agents will damage the brew unit.

Only ever clean the brew unit by hand with warm water. **Do not use any cleaning agents.**

- Clean the brew unit **by hand under warm running water** without using any cleaning agents.

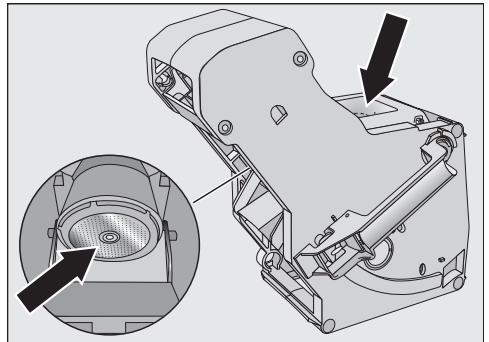

- Wipe any coffee residue from the filters. One filter is located in the funnel. The other filter can be found to the left of the funnel.
- Dry the funnel to prevent ground coffee sticking to it the next time a coffee is made.

Cleaning the inside of the appliance

- Use your vacuum cleaner or similar to remove dry coffee grounds.

Cleaning and care

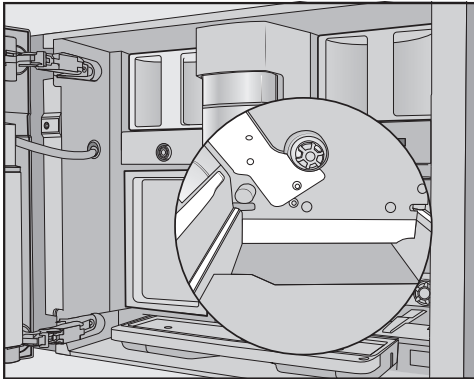

- Clean the brew unit niche with a damp, clean sponge cloth. When cleaning, pay particular attention to the areas marked in white in the illustration, e.g. around the drive shaft.

Inserting the brew unit

- To insert, follow the instructions for removal in reverse order: push the brew unit back into the coffee machine. Tilt the brew unit forward a little when doing this.

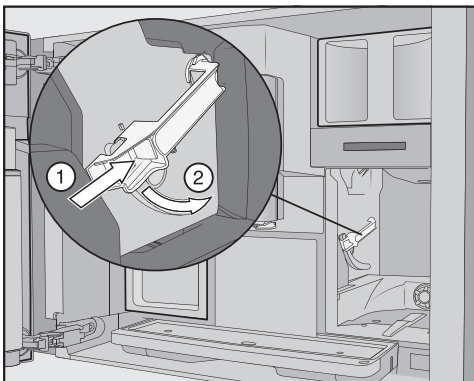

- Press the button under the handle of the brew unit ① and, whilst doing so, turn the handle backwards ②.

Tip: If you are unable to turn the brew unit handle, apply firm pressure to the sides of the brew unit.

- Push the water container into the coffee machine.

The process of removing and inserting the brew unit causes ground coffee to drop onto the drip tray.

- Remove the drip tray and clean the lid.
- Push the drip tray back into the coffee machine.
- Close the appliance door.

Cleaning the interior, inside of the appliance door and drip tray

Clean the interior and appliance front as part of the normal cleaning process. For instance, if you remove the water container, use this as an opportunity to clean the area under the water container at the same time.

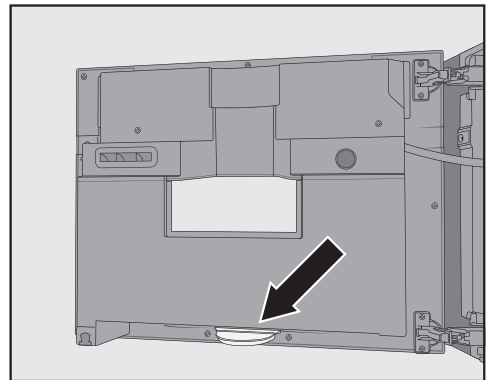

The drip tray is located at the bottom on the inside of the appliance door.

Remove and empty the drip tray on a regular basis. The drip tray is dishwasher-safe.

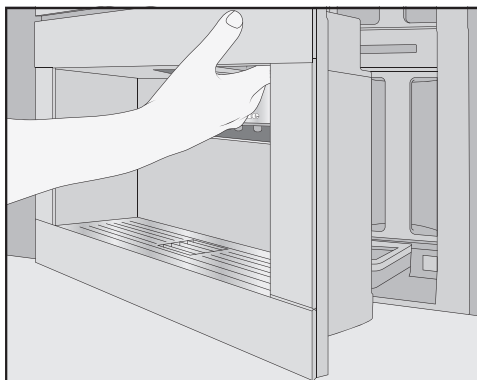

- Open the appliance door.
- Remove and clean the drip tray.
- Remove the following parts from the interior:
 - Water container
 - Drip tray
 - Maintenance container
 - Brew unit
 - Bean container

Tip: Use a vacuum cleaner to remove dry ground coffee residue.

- Clean the interior and the inside of the appliance door by hand with a clean and moist sponge cloth/microfibre cloth.
- Wipe the interior and appliance door dry using a soft cloth.
- Put all the parts back in place, including the drip tray.
- Close the appliance door.

Cleaning the appliance front

If soiling is not removed promptly, it could cause the surface to alter or discolour.

Remove any soiling on the appliance front straight away.

Make sure that water cannot get behind the display.

Clean the appliance front after manual descaling. If possible, wipe up any spillages of descaling agent immediately.

Tip: Before cleaning the control panel, open the appliance door. This will prevent accidental operation.

- Clean the appliance front with a clean and moist sponge cloth/microfibre cloth.
- After cleaning, wipe the surfaces dry using a soft cloth.

Tip: You can also use a Miele microfibre cloth to clean the appliance front.

Maintenance programmes

The coffee machine has maintenance programmes for:

- Rinsing the machine
- Rinsing the milk pipework
- Cleaning the milk pipework*
- Degreasing the brew unit*
- Descaling the machine*

* If you have not fitted any cleaning and/or descaling cartridges and have switched off automatic cleaning, you will need to run the maintenance programmes manually yourself.

Please also note that the coffee machine pipework may also have to be descaled manually at regular intervals even if a descaling cartridge has been

Cleaning and care

fitted, depending on how you use your machine and the hardness of the water used.

Opening the Maintenance menu

The drinks menu is displayed.

- Touch the ↩ sensor control.
- Select Maintenance.

You can now start the desired maintenance programme.

Rinsing the machine

If you have made a coffee drink, the coffee machine will rinse the coffee pipework automatically before switching off. You can also start the Rinse the appliance function manually.

Rinsing the milk pipework

If you have made a drink with milk, the coffee machine will rinse the milk pipework automatically after a few minutes. You can also start the Rinse the milk pipework function manually.

Maintenance programme: Clean the milk pipework

You can run the maintenance programme with the Miele cleaning cartridge or with the cleaning agent for milk pipework (small sticks of powdered cleaning agent). The maintenance programme lasts for approx. 20 minutes.

If you have switched on automatic cleaning and fitted a ready-to-use cleaning cartridge, the Clean the milk pipework maintenance programme will run using the cleaning cartridge.

Cleaning the milk pipework with the cleaning cartridge

In addition to using the automatic cleaning function, you can also start the maintenance programme manually, e.g. to clean the milk pipework after a period of intensive use.

The Maintenance menu is displayed.

- Touch Clean the milk pipework.
- Follow the instructions in the display.

Cleaning the milk pipework with the cleaning agent for milk pipework (sticks)

If automatic cleaning is switched off, the milk pipework must be cleaned after 15 days at the latest. Messages appear in the display to prompt you to clean.

For optimum cleaning results, we recommend Miele cleaning agent for milk pipework.

The powder cleaning agent for milk pipework has been specially developed for use with Miele coffee machines and prevents subsequent damage.

For each cleaning process, you will need 2 sticks of the cleaning agent for milk pipework.

You can order the cleaning agent for milk pipework via the Miele online shop, the Miele Customer Service Department or from your Miele dealer.

Clean the milk pipework will appear on the display.

- Confirm the message with *OK*.
- Follow the instructions in the display.

When Fill water container with lukewarm water and cleaning agent up to the  symbol and replace it. Close the door appears in the display, proceed as follows.

- Open **2** sticks of the cleaning agent for milk pipework and empty the contents into the water container.

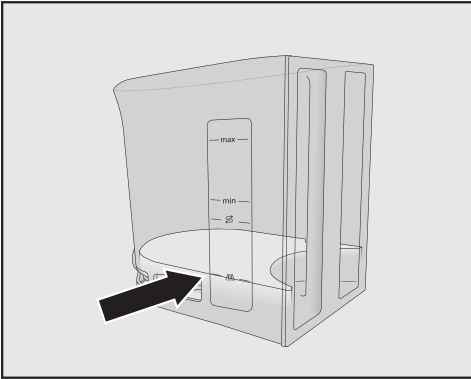

- Fill the water container with lukewarm water up to the  mark and stir the solution.

Follow the instructions for the mixing ratio carefully. Do not fill the water container with too little water. Otherwise, cleaning will be incomplete.

- Push the water container back into the machine.
- Close the appliance door.
- Follow the instructions in the display.
- If prompted to do so in the display, rinse the water container thoroughly with clean water. Make sure that **no** cleaning agent is left in the water container. Fill the water container with fresh drinking water.

The cleaning process is finished when **Process finished** appears in the display.

Degreasing the brew unit and cleaning the interior

The brew unit must be degreased regularly to ensure aromatic coffee and trouble-free operation of the coffee machine. Depending on the natural oil content of the coffee used, the brew unit can become blocked quite quickly.

You can run the maintenance programme with the Miele cleaning cartridge or with cleaning tablets for degreasing the brew unit. The maintenance programme lasts for approx. 10 minutes.

If you have switched on automatic cleaning and fitted a ready-to-use cleaning cartridge, the **Degrease the brew unit** maintenance programme will run using the cleaning cartridge.

If you have not fitted a Miele cleaning cartridge, the following message will appear in the display after 200 portions: **Degrease the brew unit.**

- Confirm the message with **OK**.

This message will keep being displayed until the brew unit has been degreased.

Degreasing the brew unit

The Maintenance menu is displayed.

- Touch **Degrease the brew unit**.

The maintenance programme will then start.

- Follow the instructions in the display.

Remove the water container and the brew unit. Rinse the brew unit by hand and clean the interior of the machine **will appear** in the display.

Cleaning and care

Cleaning the brew unit and interior

The moving parts of the brew unit are lubricated. Cleaning agents will damage the brew unit.

Only ever clean the brew unit by hand with warm water. **Do not use any cleaning agents.**

To ensure good tasting coffee and to prevent the formation of microbes in the appliance, remove and clean the brew unit under running water once a week.

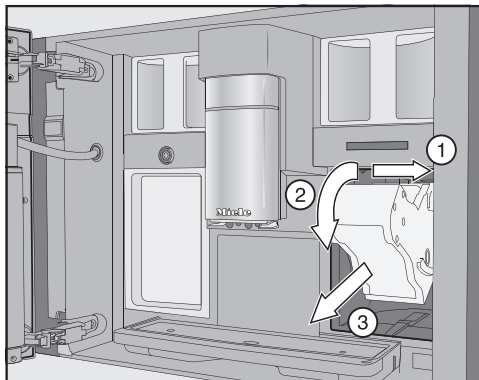

- First, pull the brew unit sideways ① and then slide it out forwards ②. While doing this, tilt the brew unit forwards ③.

If you cannot remove the brew unit or can only do so with difficulty, the brew unit is not in the correct position (see “Problem solving guide”).

When you have removed the brew unit, do **not** change the position of the handle on the brew unit. Otherwise, the brew unit cannot be reinserted.

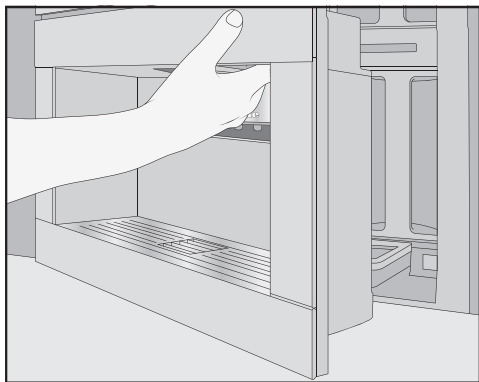

- Open the appliance door.
- Remove the water container.

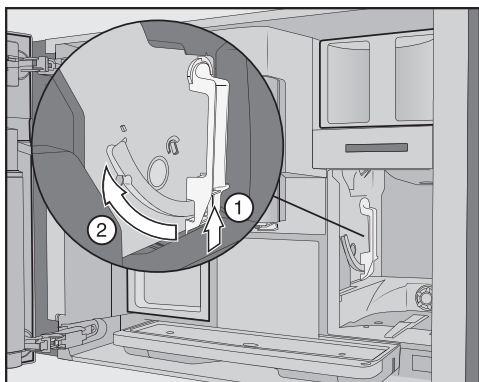

- Press the button under the handle of the brew unit ① and, whilst doing so, turn the handle forwards ②.

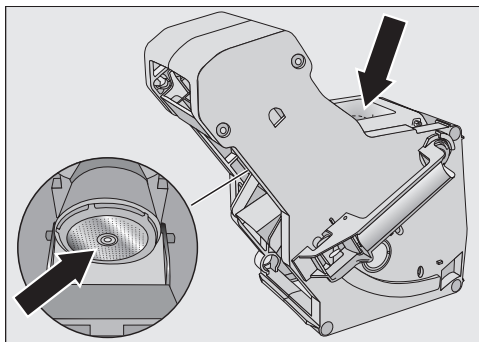

- Clean the brew unit **by hand under warm running water** without using any cleaning agents.

- Wipe any coffee residue from the filters. One filter is located in the funnel and the other to the left of the funnel.

The process of removing the brew unit causes ground coffee to drop onto the drip tray.

- Remove the drip tray and clean the lid.
- Clean the interior of the coffee machine (see also “Cleaning and care – Removing the brew unit and cleaning it by hand”). Use a vacuum cleaner to remove dry ground coffee residue.

Dropping a cleaning tablet into the brew unit

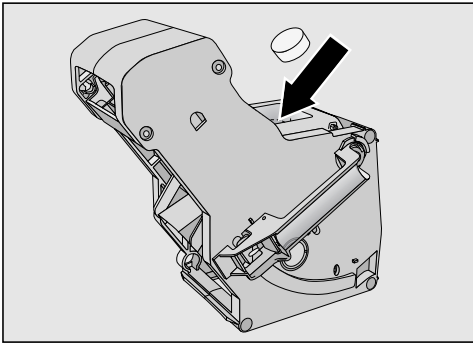

- Drop a cleaning tablet into the top of the brew unit (arrow).
- Push the brew unit containing the cleaning tablet back into the coffee machine.

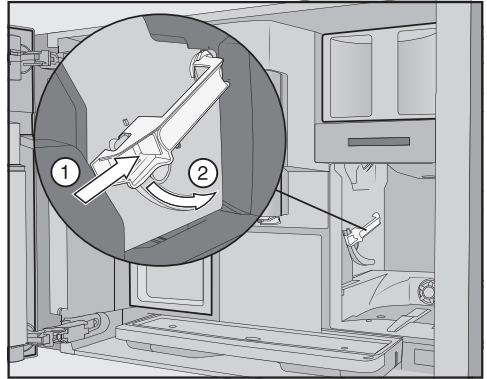

- Press the button under the handle of the brew unit ① and, whilst doing so, turn the handle backwards ②.
- Push the water container and drip tray (plus waste container) back into the coffee machine.
- Close the machine door.
- Follow the further instructions given in the display.

The cleaning process is complete when the drinks menu appears.

Descaling the machine

Risk of damage from spilt descaling solution.

Sensitive surfaces and/or natural floors can suffer damage.

Wipe up any spillages of descaling agent immediately.

Limescale builds up in the coffee machine through use. How often the appliance needs to be descaled will depend on the water hardness level in your area. Limescale must be removed regularly.

Cleaning and care

The appliance will guide you through the descaling process. Various messages will appear in the display, e.g. you will be prompted to empty the drip tray or fill the water container.

Descaling **must be carried out**. The process takes approx. 35 minutes.

Even if you activate automatic descaling, the pipework may still have to be descaled manually with the *Descal* the appliance maintenance programme at regular intervals, depending on how you use your machine.

If you have not fitted a descaling cartridge, the display will remind you when you need to descale the coffee machine.

No. of uses until appliance needs descaling: 50 will appear in the display. As of this point, the display will indicate how many more drinks can be made before descaling becomes absolutely essential. This number is indicated whenever a drink is made.

■ Confirm the message with *OK*.

When the number of remaining portions reaches 0, the coffee machine will lock out.

You can switch the coffee machine off if you do not want to run the descaling programme at this point in time. You can not make any drinks until the machine has been descaled.

Descaling after prompt appears in the display

Descal the appliance will appear in the display.

■ Confirm the message with *OK*.

The process will start.

■ Follow the instructions in the display.

When Place 2 descaling tablets in the water container and fill it with lukewarm water up to the descaling symbol S and insert it appears in the display, proceed as follows.

Preparing the descaling solution

For optimum descaling results, we recommend using the Miele descaling tablets provided.

The descaling tablets have been specially developed for Miele coffee machines.

Other descalers, which contain other acids besides citric acid and/or other undesirable substances, such as chlorides for example, can cause damage to the product. Moreover, the descaling result required cannot be guaranteed if the descaling solution was not of the appropriate concentration.

Miele descaling tablets are available to order via the Miele webshop, from the Miele Customer Service Department (see the end of this booklet for contact details) or from your Miele dealer.

You will need **2** descaling tablets.

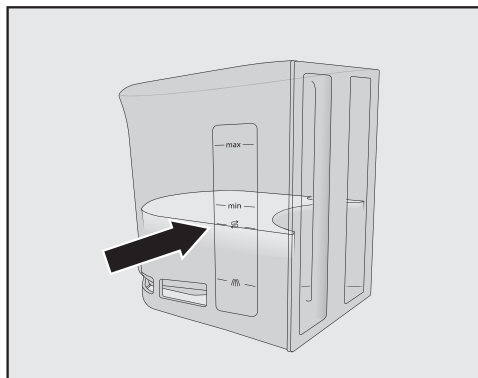

■ Fill the water container to the S mark with lukewarm water.

- Add **2** descaling tablets to the water container.

Follow the instructions for the descaler mixing ratio carefully. It is important that you do not fill the water container with too much or too little water. Otherwise, the descaling process will be cancelled prematurely.

Carrying out descaling

- Push the water container back into the machine.
- Follow the further instructions given in the display.

When Rinse and refill the water container appears in the display:

- Remove the water container and rinse it thoroughly with clean water. Ensure that **no** descaling solution residue remains in the water container. Fill the water container with drinking water.

The descaling process is complete when the drinks menu appears.

Automatic cleaning and descaling

Risk of damage from spilt cleaning and descaling solution.

Sensitive surfaces and/or natural floors can suffer damage.

One way to catch the cleaning and descaling solution is to place the maintenance container under the central spout before switching off the machine.

Clear up any spillages of cleaning and descaling solution.

When handling a descaling cartridge which has already been filled with water, ensure that the descaling solution does not come into contact with sensitive surfaces.

The coffee machine features automatic maintenance programmes for cleaning the milk pipework and brew unit, and for descaling the appliance. For this, the Miele cleaning and descaling cartridges must be fitted in the coffee machine. If both types of maintenance programme are due to run on the same day, automatic cleaning will always be performed before automatic descaling (total time: approx. 35 minutes).

You can set the time for starting cleaning and descaling via the Maintenance Timer.

The coffee machine will automatically determine the days when to carry out automatic descaling based on the usage pattern.

During automatic cleaning, the milk pipework gets cleaned and/or the brew unit gets degreased. The coffee machine also determines the cleaning solution concentration and the cleaning programme type for automatic cleaning based on the number and types of drinks made.

If you do not make any drinks, the automatic maintenance programmes will not be started.

In order to run the automatic cleaning programmes, a solution is prepared by mixing water with the cleaning agent. This solution is then pumped through the coffee machine pipework. After the defined activation time, all the solution is rinsed out of the pipework and the machine can then be used as normal for making drinks.

During automatic cleaning and descaling, you will hear various noises (e.g. rinsing noises) at frequent intervals even though the appliance is switched off.

Please note before and during the automatic maintenance programmes:

The coffee machine must be ready to use and the following conditions must be met:

- Ready-to-use cleaning and descaling cartridges are fitted.
- The coffee machine must **not** be disconnected from the mains power supply during the automatic maintenance programmes.
- The drip tray, brew unit and central spout are inserted.
- The water container is inserted and is filled with water at least up to the  mark.
- Carry out the instructions which appear in the display before switch-off, e.g. Empty and refit the drip tray and the waste container.
- The appliance door is closed when the programme is started.
- The coffee machine is switched off.

Automatic cleaning

If you have made a drink containing milk, the milk pipework will be cleaned 4 days later at the latest.

If you have made a coffee, the brew unit will be degreased 15 days later at the latest.

Automatic cleaning takes approx. 25 minutes.

Switching automatic cleaning on and off

It is usual to switch on automatic cleaning as part of the process of setting up the coffee machine.

However, Automatic cleaning can be switched on or off at any time.

The drinks menu is displayed.

- Touch the ↩ sensor.
- Select **Settings** and then **Automatic cleaning**.
- Select the setting you want and confirm with **OK**.

If coffee drinks and/or milk have already been dispensed when automatic cleaning is switched on, you will need to clean the coffee machine manually as a one-off operation. This will remove any milk residues and coffee oils, and will reset the counter.

The Miele cleaning cartridge

Only use the Miele cleaning cartridge for automatic cleaning. It has been developed specifically for use in this coffee machine.

Please note that the Miele cleaning cartridge has a lifespan of approx. 1 year after it has been placed in the machine.

Critical for the one-year lifespan is the date on which the cleaning cartridge was fitted.

Do not fill the cleaning cartridge with other fluids or substances.

The Miele cleaning cartridge contains a cleaning agent for the effective removal of milk residues and coffee oils.

The Miele cleaning cartridge will last for up to 3 months of automatic cleaning, depending on how often the coffee machine is used. Frequent manual cleaning or a large number of drinks will shorten this period accordingly.

You can display the cartridge fill level as a segment bar under **Settings | Info | Fill levels**. As the cartridge fill level decreases, various messages will appear at regular intervals to remind you to have a new cartridge at the ready.

The first message will appear when the cartridge is approx. 25 % full.

Cleaning cartridges are available to order via the Miele webshop or directly from Miele (see back cover for contact details).

Automatic cleaning and descaling

If **no** cleaning cartridge has been fitted or if the fitted cartridge is **empty** or has **expired**, the milk pipework and brew unit must be cleaned manually. For this, you will need the appropriate cleaning agents (see “Cleaning and care” – “Cleaning the milk pipework” and “Degreasing the brew unit”).

You can leave the cleaning cartridge in place during long periods of non-use or when transporting the coffee machine.

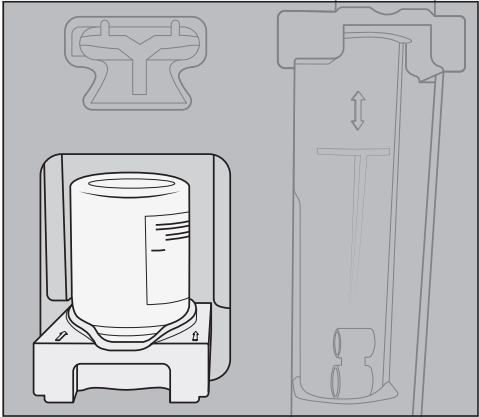

Replacing the cleaning cartridge

Cleaning cartridges are available to order via the Miele online shop, the Miele Customer Service Department or your Miele dealer.

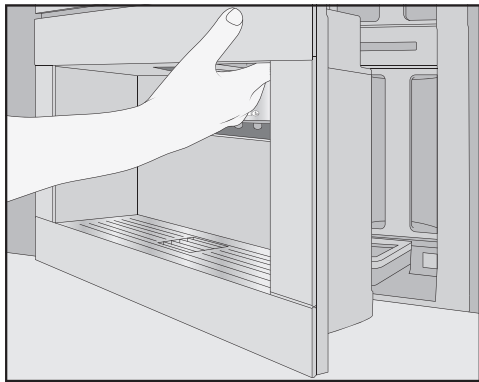

- Open the appliance door.
- Remove the maintenance container.

- Pull the holder containing the cartridge forwards and remove them both.
- Unscrew the cleaning cartridge from the holder.
- Dispose of the spent cartridge with your household waste.

Cleaning agent residue can sometimes dry on the holder, leaving white deposits behind. These residues will not affect the automatic cleaning programme. If necessary, you can wipe the residues off with a damp cloth or put the holder in the dishwasher.

- Take the new cartridge out of its packaging.
- Unscrew the screw cap.

The cap is no longer required.

Automatic cleaning and descaling

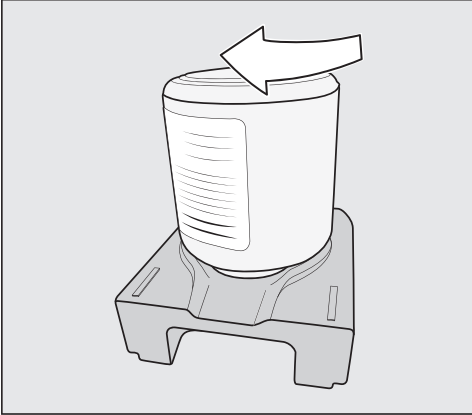

- Screw the new cartridge into the holder upside down.
- Push the holder and cartridge into the coffee machine until the holder audibly clicks into place.
- Put the maintenance container back inside the appliance.
- Close the appliance door.

Automatic descaling

Automatic descaling takes approx. 12 minutes.

To ensure the longevity of components and a consistent environment free of limescale, the coffee machine needs to be manually descaled from time to time. The intervals are determined by your usage behaviour and the water hardness level of your area. If you make a lot of coffees with milk, for example, you will need to descale the coffee machine more frequently with the descaling tablets.

The Miele descaling cartridge

Only use the Miele descaling cartridge for the automatic descaling programme.

Please note that the Miele descaling cartridge has a lifespan of approx. 1 year after it has been placed in the coffee machine and filled with water for the first time. Critical for the one-year lifespan is the date on which the descaling cartridge was fitted and filled with water.

Do not fit a descaling cartridge that has already been used in another Miele coffee machine. Your coffee machine will have no information about the fill level of this cartridge. The descaling effect may be insufficient and damage your coffee machine.

Do not fill the descaling cartridge with other fluids or substances.

The descaling agent comes in the form of tablets in the descaling cartridge. The cartridge is filled with water when it is placed in the coffee machine. The tablets gradually dissolve over time.

The descaling cartridge will last for 7 to 12 months of automatic descaling, depending on how often the coffee machine is used.

You can display the cartridge fill level as a segment bar under [Settings](#) | [Info](#) | [Fill levels](#). As the descaling cartridge fill level decreases, various messages will appear at regular intervals to remind you to have a new cartridge at the ready.

The Miele descaling cartridge is available to order from the Miele online shop, Miele Customer Service Department or your Miele dealer.

Automatic cleaning and descaling

If a descaling cartridge is **not** fitted, an **empty** cartridge is fitted or an **expired** cartridge is fitted, the coffee machine needs to be descaled using the Descale the appliance maintenance programme. To do this, the appropriate descaling agent is required (see “Cleaning and care – Descaling the machine”).

The descaling cartridge can remain fitted even if the machine is not used for a long time. Remove the cartridge before transporting the coffee machine. However, please note the following:

- Once filled with water, the descaling cartridge has a max. shelf life of 3 weeks outside of the coffee machine.
- The descaling cartridge should be transported with care and upright. Avoid shaking it. Shaking or turning upside down reduces the service life or damages the cartridge.
- The cartridge should be stored upright, in a dark place and at room temperature (16–38 °C).

Replacing the descaling cartridge

Removing the descaling cartridge

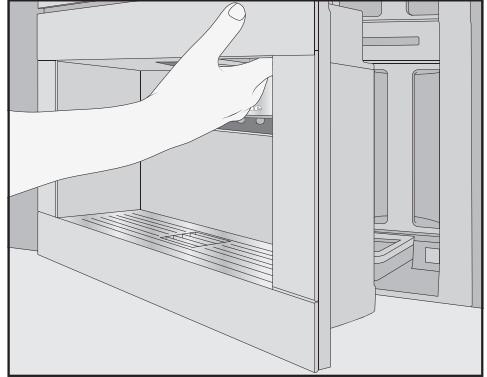

- Open the appliance door.
- Remove the maintenance container.

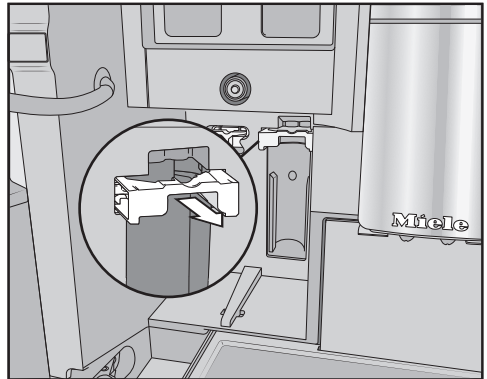

- Pull the cartridge holder forwards.
- Remove the cartridge.

Automatic cleaning and descaling

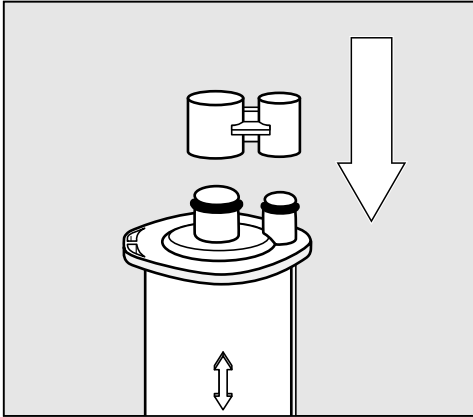

Tip: You can seal the descaling cartridge with the cap that can be found on the cartridge. This cap can be easily detached by snapping it off.

- Dispose of the cartridge with your household waste.

Fitting the descaling cartridge

- Insert the cartridge and push it upwards as far as it will go.
- Push the cartridge holder back and then put the maintenance container in place.
- Close the appliance door.
- Follow the instructions in the display.

The next time the coffee machine is switched off, the new descaling cartridge will also fill with water when the machine is rinsed. You will hear water being pumped into the cartridge at frequent intervals.

Always wait for the coffee machine to switch itself off. Do not force the machine to switch off.

Choosing not to use a descaling cartridge

If you do not want to fit a descaling cartridge, seal the system with the adapter.

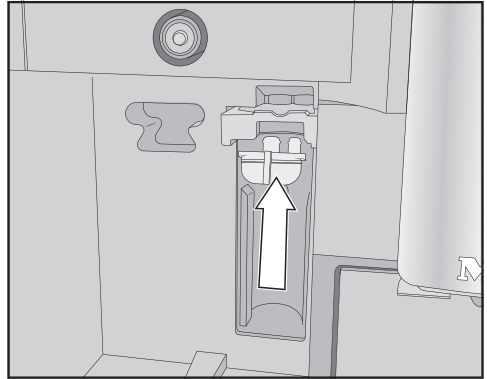

- Insert the adapter in place of the cartridge.

Maintenance Timer

Use the Maintenance Timer to select any start time you like for the automatic maintenance programmes.

Please note that the automatic maintenance programmes can take a maximum of around 35 minutes to run.

You can set different start times for the weekend and/or for Monday to Friday.

Automatic cleaning and descaling

Setting the Maintenance Timer

The drinks menu is displayed.

- Touch the ↵ sensor control.
- Select Maintenance.
- Select Maintenance timer.
- Change the settings as required.
- Confirm with *OK*.

The start time is saved. From now on, the automatic maintenance programmes will commence at the desired time each day.

Cancelling automatic cleaning and descaling

You can cancel the automatic cleaning programmes during the activation time.

If the automatic cleaning programme is not performed **five times** in a row, the dispensing of drinks is blocked. You will only be able to make drinks again once the brew unit has been degreased and/or the milk pipework has been cleaned.

- Touch the On/Off switch ①.

The time left in hours is shown in the display.

- Touch Cancel.

The cleaning or descaling solution is rinsed out of the pipework. Rinsing can take up to 5 minutes. You can now make drinks.

Many malfunctions and faults that can occur in daily operation can be easily remedied. You can save time and money in many cases, as you do not need to call the Miele Customer Service Department.

Information to help you rectify faults yourself can be found at www.miele.com/service.

The following tables are designed to help you to find the cause of a malfunction or a fault and to resolve it.

Messages in the display

Error messages must be confirmed with *OK*, otherwise the message can reappear in the display even though the problem has been remedied.

Follow the instructions which appear in the display to remedy the problem.

If after this, the fault message appears in the display again, contact Miele Service.

Problem	Cause and remedy
F1, F2, F80, F82 F353, F354	There is an internal fault. ■ Switch the coffee machine off. Wait for approximately 1 hour before switching the machine back on again.
F74, F77 F225, F226 F235, F353, F354	There is an internal fault. ■ Switch the coffee machine off. Wait for approximately 2 minutes before switching the machine back on again.

Problem solving guide

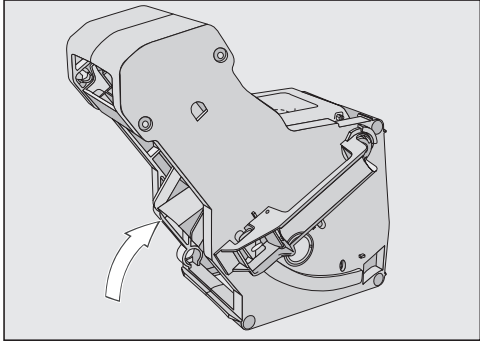
Problem	Cause and remedy
<p>F73 or Check the brew unit</p>	<p>The brew unit cannot be positioned correctly or is soiled. It is not possible to press the ground coffee.</p> <ul style="list-style-type: none"> ■ Check whether you can remove the brew unit. ■ If you can remove the brew unit, rinse it under running water.  <ul style="list-style-type: none"> ■ Push the coffee ejector of the brew unit into the correct position (see illustration). ■ Place the water container in the coffee machine and close the machine door. Do not insert the brew unit. Switch the coffee machine on. <p>This will initialise the brew unit motor and put it back into the start position.</p> <ul style="list-style-type: none"> ■ When Insert the brew unit appears in the display, put the brew unit back in the coffee machine. ■ If you cannot remove the brew unit, switch the coffee machine off. Wait for approximately 2 minutes before switching the machine back on again.
<p>A manual maintenance programme is prematurely aborted and the following appears in the display: Push the water container in until it engages.</p>	<p>The water container has not been filled and inserted correctly.</p> <ul style="list-style-type: none"> ■ Check that you have selected the correct mark. <p>The symbols marked on the water container indicate the amount of water required for the Descale the appliance: ☞ and Clean the milk pipework: ☞ maintenance programmes.</p> <ul style="list-style-type: none"> ■ Fill the water container up to the relevant mark and restart the process.

Problem solving guide

Problem	Cause and remedy
F233	<p>The cup rim sensor is not inserted or is incorrectly inserted.</p> <p>If the central spout is moving upwards and the cup rim sensor is bumped, e.g. with a cup, the cup rim sensor loses its reference position.</p> <ul style="list-style-type: none">■ Confirm the message with <i>OK</i>.■ Refit the cup rim sensor. <p>Cup rim detection remains inactive and the central spout stays in the top position until the coffee machine is next switched on. Cup rim detection is reinitialised during the next switch-on operation.</p>
F 355, F 357–F 362	<p>The bean system must be set up again, e.g. coffee beans have possibly got jammed.</p> <ul style="list-style-type: none">■ Open the machine door and remove both bean containers from the coffee machine.■ Close the machine door. <p>The bean system is set up.</p> <ul style="list-style-type: none">■ Follow the instructions in the display.
F 307 or Remove the milk valve and clean it	<p>The milk valve is faulty.</p> <ul style="list-style-type: none">■ Remove and clean the milk valve (see “Cleaning and care – Removing and cleaning the milk valve”).

Problem solving guide

Unusual performance of the coffee machine

Problem	Cause and remedy
The display remains dark when the coffee machine is turned on using the On/Off button ①.	The On/Off button ① was not held for long enough. ■ Touch and hold the On/Off button ① for at least 3 seconds.
	The plug is not inserted in the socket correctly. ■ Insert the plug into the socket.
	The fuse has tripped because the coffee machine, voltage or another appliance is defective. ■ Switch off at the wall socket and remove the plug. ■ Contact a qualified electrician or the Miele Customer Service Department.
The lighting remains off after the coffee machine has been switched on.	The lighting has been switched off. ■ Switch the lighting on (see “Settings - Lighting”).
	The lighting is faulty. ■ Call Service.
The time of day is being displayed but the ☀ sensor and movement sensor are failing to respond.	This is not a fault. The QuickTouch function is switched off. Select Display QuickTouch On so that the ☀ sensor and movement sensor respond even when the coffee machine is switched off.
The coffee machine does not respond to operation via the display.	There is a fault. ■ Touch and hold the On/Off button ① until the display switches off and the machine restarts.
The coffee machine turns off suddenly.	The factory set switch-off time (20 minutes) or the switch-off time you have programmed has been reached. ■ If required, you can select a new switch-off time (see “Settings – Timer”).
	The plug is not inserted in the socket correctly. ■ Insert the plug into the socket.
The sensors do not respond to touch. The coffee machine can no longer be operated.	There is an internal fault. ■ Disconnect the coffee machine from the power supply.

Problem solving guide

Problem	Cause and remedy
<p>A fan can be heard even though no drinks are being prepared or the coffee machine is switched off.</p>	<p>This is not a fault. Once a drink has been dispensed or the machine has been switched off, the internal fan will continue to run until the interior is sufficiently dehumidified.</p>
<p>The brew unit cannot be removed.</p>	<p>The brew unit is not positioned correctly.</p> <ul style="list-style-type: none"> ■ If necessary, move the handle on the brew unit back to the start position. Close the machine door. ■ Switch the coffee machine off. ■ Wait approx. 1 minute before switching the coffee machine back on. <p>This will initialise the brew unit motor and put it back into the start position.</p> <ul style="list-style-type: none"> ■ If necessary, repeat these steps.
<p>Coffee dispensing is repeatedly interrupted and the message <small>Fill the bean container</small> appears in the display.</p>	<p>This is not a fault. The brew unit has not detected the ground coffee. Certain types of coffee produce a small amount of coffee when they are ground. In such cases, the grinder is usually set to fine and the minimum quantity of coffee is set.</p> <ul style="list-style-type: none"> ■ Confirm the message with <i>OK</i>. <p>If the display appears with all types of coffee:</p> <ul style="list-style-type: none"> ■ Set the grinder to a coarser setting (see “Grinder setting”). ■ Select a larger quantity of coffee. <p>Don’t forget to check any drinks changed in “Profiles”.</p> <p>If the message only appears when dispensing certain drinks:</p> <ul style="list-style-type: none"> ■ Check the quantity of coffee set for this drink (see “Quantity of coffee”). Select a larger quantity of coffee. ■ You may also need to set a coarser grinder setting.
<p>Drink dispensing is prematurely aborted even though there is a container under the central spout.</p>	<p>This is not a fault. If the container has a very wide opening that prevents the cup rim sensor from making contact with the edge of the container (e.g. in the case of a very large cup), the drink will be cancelled. Use a different container or position the existing one so that the sensor can detect the rim.</p>

Problem solving guide

Problem	Cause and remedy
<p>The coffee machine does not switch itself on even though the On at timer setting has been activated.</p>	<p>The system lock has been activated. ■ Deactivate the system lock.</p> <hr/> <p>The current day of the week has not been selected. ■ Check the timer settings and change these if necessary.</p> <hr/> <p>The coffee machine was not used after being switched on automatically three times in succession (holiday mode). ■ Switch the machine on and dispense a drink.</p> <hr/> <p>The coffee machine does not switch on with the On at timer while automatic descaling is being carried out. This is not a fault. Select a different timer setting.</p>
<p>Steam is dispensed instead of water while preparing hot water or making tea.</p>	<p>It is likely that the wrong altitude has been set. ■ Change the altitude settings (Settings Altitude). ■ If necessary, you can also change the temperature settings for the drinks (Drink parameters).</p>
<p>The display is hard to see or not able to be read.</p>	<p>The display brightness has been set too low. ■ Change this setting (see “Settings”).</p>
<p>The display lights up but the coffee machine does not heat up and no drinks are made.</p>	<p>The demo mode for demonstrating the coffee machine in the showroom has been activated. ■ Deactivate demo mode (see “Settings”).</p>

Faults with automatic cleaning and/or descaling

Problem	Cause and remedy
<p>After switching on, a message appears informing you that automatic cleaning and/or descaling could not be carried out.</p>	<p>The coffee machine was not ready for operation: all removable parts, such as the water container, drip tray, brew unit and central spout, must be installed. The water container was not filled with drinking water at least up to the descaling symbol ☞.</p> <p>The machine door was not closed.</p> <ul style="list-style-type: none"> ■ Confirm the message with <i>OK</i>. ■ Make sure that the coffee machine is ready to use before the next automatic cleaning and/or descaling process.
	<p>The coffee machine was not switched off at the start time.</p> <p>The automatic maintenance programmes will only start if the coffee machine is switched off.</p> <ul style="list-style-type: none"> ■ Confirm the message with <i>OK</i>. ■ Change the start time if necessary.
<p>Descal the appliance appears even though a ready-to-use descaling cartridge has been fitted. Drinks cannot be made.</p>	<p>Depending on the water hardness level in your area and your usage behaviour, the coffee machine needs to be descaled using the maintenance programme occasionally.</p> <p>For this you will need to use Miele descaling tablets.</p> <ul style="list-style-type: none"> ■ Descal the coffee machine using the maintenance programme (see “Cleaning and care – Descaling the machine”).

Problem solving guide

Problem	Cause and remedy
<p>When the machine is switched on, one of these messages appears: Automatic cleaning could not be carried out. Start Automatic cleaning (duration min.) now? Otherwise Automatic cleaning will be permanently switched off</p> <p>Or: Automatic maintenance could not be carried out. Carry out the Automatic cleaning part of the Automatic maintenance programme (duration min.) now? Otherwise the Automatic cleaning part of the Automatic maintenance programme will be permanently switched off</p> <p>No drinks can be made.</p>	<p>Automatic cleaning could not be carried out five times.</p> <p>If you want the coffee machine to continue cleaning the milk pipework and degreasing the brew unit automatically:</p> <ul style="list-style-type: none">■ Make sure that the coffee machine is ready for automatic maintenance (see “Automatic cleaning and descaling”).■ Touch <i>OK</i> to start automatic cleaning. <p>If you select <i>No</i> to switch automatic cleaning off, you will have to clean the milk pipework and degrease the brew unit manually (see “Cleaning and care”). For this, you will need the cleaning agent for milk pipework and the tablets for degreasing the brew unit.</p>

Unsatisfactory results

Problem	Cause and remedy
The coffee is not hot enough.	The cup has not been pre-heated. The smaller the cup and the thicker its sides, the more important it is to pre-heat it. ■ Pre-heat the cup, for example, with hot water.
	The brewing temperature has been set too low. ■ Set a higher brewing temperature.
	The filters in the brew unit are blocked. ■ Remove the brew unit and clean by hand ■ Degrease the brew unit.
The coffee grinder makes a louder noise than usual.	The coffee bean container has become empty during the grinding process. ■ Fill the coffee bean container with fresh beans.
	There may be foreign objects such as plastic or stones in amongst the coffee beans. ■ Switch the coffee machine off immediately. Call Service.
The coffee is dispensed too slowly into the cup.	The brew unit is blocked. ■ Degrease the brew unit (see “Cleaning and care – Degreasing the brew unit and cleaning the interior”).
There is no crema on the coffee or espresso.	The coffee beans are no longer fresh. If roasted coffee beans are stored open for too long, the carbon dioxide gradually escapes from the coffee beans. The crema is no longer formed during dispensing. Of course, you can still use the coffee beans.

Problem solving guide

Problem	Cause and remedy
<p>The coffee tastes weak. The coffee grounds in the waste container are sludgy and grainy.</p>	<p>Less coffee is being brewed because insufficient coffee beans are getting into the grinder. Have you used a dark roast?</p> <p>This type of coffee bean is often more oily. These oils can cling to the inside of the bean containers and hinder the flow of beans.</p> <p>Are you using a type of coffee with very large beans or different sized beans?</p> <p>The beans are possibly getting wedged or jammed and forming “bean bridges”.</p> <ul style="list-style-type: none"> ■ Clean the bean containers more often if you are using darker, more oily coffee beans. ■ If you are using a type of coffee with very large beans or different sized beans, pull the bean containers out slightly and give them a shake. ■ If necessary, try using a different type of coffee.
<p>Coffee is not being dispensed from both spouts evenly. Milk may be sputtering when being heated up.</p>	<p>Coffee deposits in the central spout are obstructing dispensing.</p> <ul style="list-style-type: none"> ■ Take the central spout apart and wash all the components – with the exception of the stainless steel cover – in the dishwasher. <p>This cleaning operation should be performed once a week.</p>
<p>The consistency of the milk froth is unsatisfactory.</p>	<p>The milk temperature is too high. Good milk froth can only be achieved with cold milk (below 10 °C).</p> <ul style="list-style-type: none"> ■ Check the temperature of the milk in the milk flask. <hr/> <p>The milk pipework is blocked and/or the milk valve is soiled.</p> <ul style="list-style-type: none"> ■ Remove and clean the milk valve.

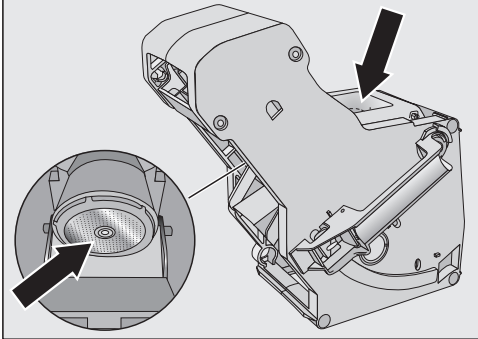
Problem	Cause and remedy
Coffee drinks trickle/dribble slowly out of the central spout.	<p>The brew unit is blocked because the coffee machine has been used very intensively. And/or the brew unit has not been regularly removed and cleaned by hand.</p> <ul style="list-style-type: none">■ If a cleaning cartridge is fitted, start by switching off Automatic cleaning (Settings Automatic cleaning).■ Run the Degrease the brew unit maintenance programme with 1 cleaning tablet (see “Cleaning and care – Degreasing the brew unit and cleaning the interior”).  <ul style="list-style-type: none">■ It is particularly important to clean the filters in the brew unit thoroughly.■ If necessary, switch on Automatic cleaning before you start making a drink. <p>Otherwise, the Clean the milk pipework and Degrease the brew unit maintenance programmes will have to be run again.</p>

After sales service and warranty

Information to help you rectify faults yourself and about Miele spare parts can be found at www.miele.com/service.

Contact in the event of a fault

In the event of any faults which you cannot remedy yourself, please contact your Miele dealer or the Miele Customer Service Department.

You can book a Miele Customer Service Department call-out online at www.miele.com/service.

Contact information for the Miele Customer Service Department can be found at the end of this document.

Please quote the model identifier and serial number of your appliance (Fabr./SN/Nr.) when contacting the Miele Customer Service Department. This information can be found on the data plate.

Please note that telephone calls may be monitored and recorded for training purposes and that a call-out charge will be applied to service visits where the problem could have been resolved as described in this booklet.

Warranty

For information on the appliance warranty specific to your country please contact Miele. See back cover for address.

In the UK, your appliance warranty is valid for 2 years from the date of purchase. However, you must activate your cover by calling 0330 160 6640 or registering online at www.miele.co.uk.

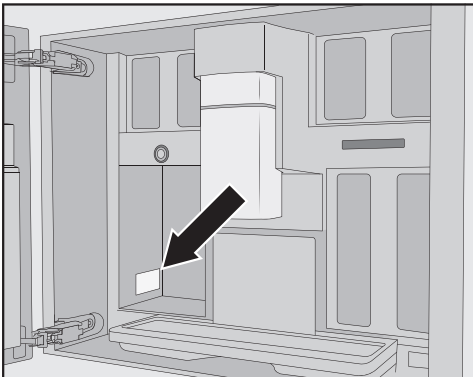

These products and other useful accessories can be ordered via the Miele webshop, from Miele (see back cover for contact details) or from your Miele dealer.

- **Microfibre cloth**
for removing finger marks and light soiling
- **Cleaning agent for milk pipework**
for cleaning the milk system
- **Cleaning tablets**
for degreasing the brew unit
- **AutoCleaner**
for automatically cleaning the milk pipework and brew unit
- **Descaling cartridge**
for automatic descaling
- **Descaling tablets**
for manual descaling
- **CJ Jug 1.0 l**
Insulated flask for coffee or tea (pot function)
- **Miele Black Edition One for all**
Whole coffee beans – perfect for making espresso, café crema and speciality coffees with milk
- **Miele Black Edition Espresso**
Whole coffee beans – perfect for making espresso
- **Miele Black Edition Café Crema**
Whole coffee beans – perfect for making coffee
- **Miele Black Edition Decaf**
Whole coffee beans – perfect for making decaffeinated speciality coffees
- **Miele Tea – LivelyGreen**
green tea

- **Miele Tea – BestBerry**
fruit tea
- **Miele Tea – PerfectMorning**
black tea

Items supplied will vary depending on appliance and country. To find out which accessories and cleaning and care products are available in your country, please go to the website or contact the Miele Customer Service Department or your Miele supplier.

Installation

Electrical connection

The coffee machine is supplied with a mains cable and moulded plug ready for connection to a suitable earthed socket.

The socket must be easily accessible after the coffee machine has been installed. If the socket is not easily accessible, ensure that a suitable means of disconnection for each pole is provided on the installation side.



Risk of fire from overheating.

Connecting the coffee machine to multi-socket adapters or extension cables can overload the cables.

For safety reasons, do not use multi-socket adapters, extension cables, adapters and/or energy-saving plugs.

The electrical system must comply with local and national safety regulations (BS 7671 in the UK).

For safety reasons, we recommend using a type  residual current device (RCD) in the relevant electrical installation for connecting the coffee machine.

If the mains connection cable is damaged, it must only be replaced with a specific mains connection cable of the same type (available from the Miele Customer Service Department). For safety reasons, such replacement may only be carried out by a qualified specialist or the Miele Customer Service Department.

The data plate indicates the nominal power consumption.

The fuse rating must be at least 10 A. Compare this information with the data of the on-site electrical connection. If in any doubt, consult a qualified electrician.

Temporary or permanent operation on an autonomous power supply system or a power supply system that is not synchronised with the mains power supply (e.g. island networks, backup systems) is possible. A prerequisite for operation is that the power supply system complies with the specifications of EN 50160 or an equivalent standard. The function and operation of the protective measures provided in the domestic electrical installation and in this Miele product must also be maintained in isolated operation or in operation that is not synchronised with the mains power supply, or these measures must be replaced by equivalent measures in the installation. As described, for example, in the current version of VDE-AR-E 2510-2.

Building-in dimensions

Installation in a tall unit

Maintain a minimum installation height of 850 mm.

All dimensions are given in mm.

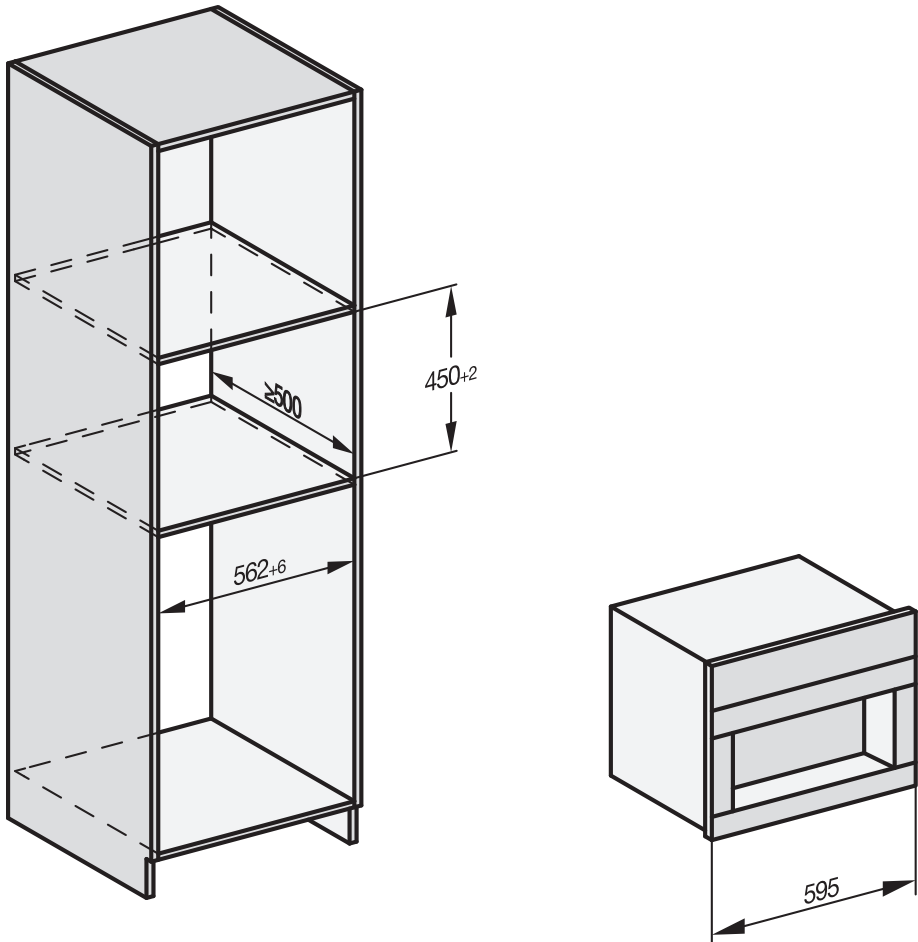

The appliance can be combined with other Miele built-in appliances. If the coffee machine is to be built in above another appliance, there must be a full-width, closed intermediate shelf between them. If the appliance is to be combined with a Gourmet drawer/built-in vacuum drawer, no intermediate shelf is required in between.

Installation

Installation and connections

All dimensions are given in mm.

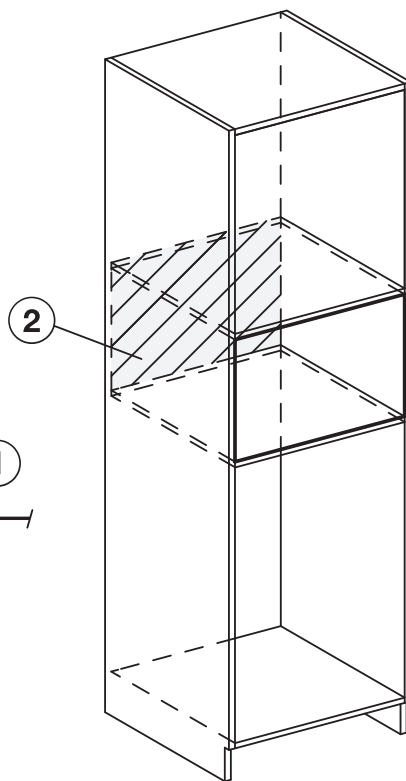
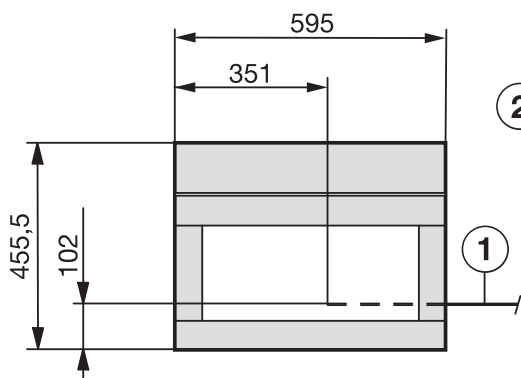

- ① Mains connection cable
- ② No electrical connection in this area

Building in the coffee machine

 Danger of injury due to incorrect operation.

An appliance that has not been built in is not safe and can cause injuries. Only ever use the coffee machine once it has been built-in.

 Danger of damage due to incorrect operation.

If the ambient temperature range is not observed, the coffee machine may not function properly. Only ever operate the coffee machine when the ambient temperature is within the range of +16 °C to +38 °C.

Maintain a minimum installation height of 850 mm.

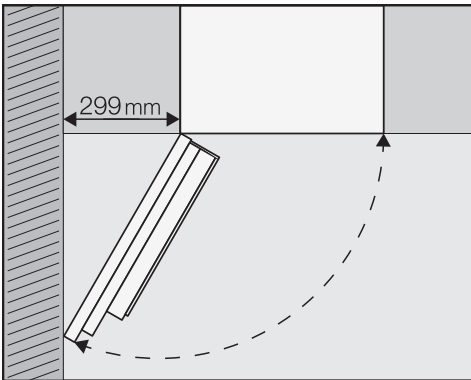

Tip: If a gap of at least 299 mm is maintained between the wall and the coffee machine, you will be able to open the appliance door wider, making the machine easier to use. For instance, it will be easier to remove the left-hand bean container.

To install the machine, you will need a TX 20 screwdriver.

Tip: It is useful to have somewhere at the height of the niche to place the coffee machine on. This will make it easier to connect the appliance to the electricity supply.

Connecting the electricity supply

Observe the information under “Electrical connection”.

- Connect the coffee machine to the electricity supply.

Removing the transport safety device

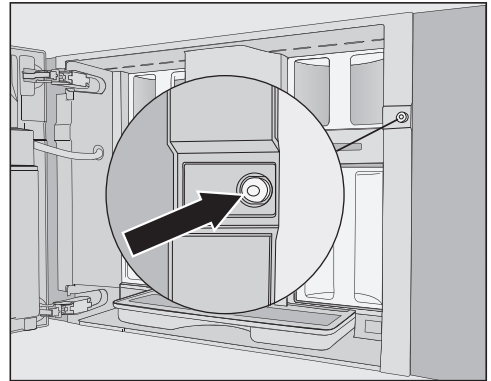

There is a red silicone plug inside the screw hole, which secures the appliance door during transport to prevent transport damage.

Remove the silicone plug **before** screwing the coffee machine to the cabinet.

- Pull firmly on the red silicone plug to remove it from the screw hole.

The silicone plug is not required again. Dispose of it with your household waste.

Installation

Pushing in and aligning the coffee machine

Take care not to trap or damage the electrical connection when pushing the appliance into the niche.

- Push the coffee machine all the way into the niche until you feel some resistance.

Never align the coffee machine by adjusting the door hinges. This will prevent the milk container from attaching correctly and interfere with the milk preparation process.

- Check the height of the coffee machine to make sure that it is sitting centrally in the niche and that it is level. Align the appliance if necessary.

You can now screw the coffee machine to the cabinet.

Screwing the coffee machine to the cabinet

- Open the appliance door.

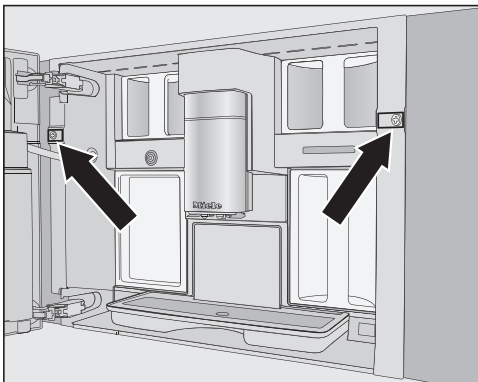

2 TX20 (25 mm) screws are supplied with the appliance.

- Secure the coffee machine to the side walls of the cabinet using the screws supplied.

- Tighten both screws by hand.

Tip: To make it easier to attach the screw on the left, you can remove the door opening limiters and increase the door opening angle to approx. 170° (see “Door opening limiters”). Make sure that there is sufficient space available and that the appliance door is not going to hit an adjacent wall.

- Check that the coffee machine is working correctly.

Door opening limiters

The coffee machine door hinges are equipped with door opening limiters that restrict the opening angle of the machine door to approx. 120°. This will prevent the machine door from hitting an adjacent wall and being damaged when opened.

The door opening limiters can be removed, allowing you to increase the opening angle to approx. 170°. This makes it easier to remove the bean containers, for example.

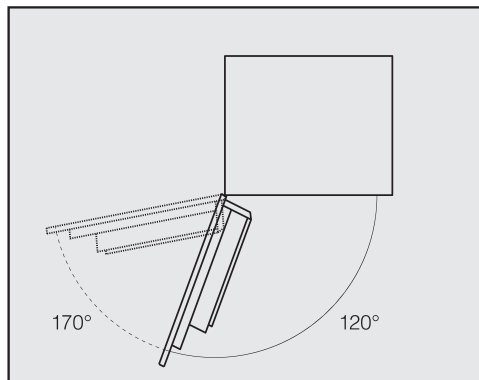

Removing the door opening limiters

Make sure that sufficient space is available for the larger door opening angle and that the machine door is not going to hit an adjacent wall.

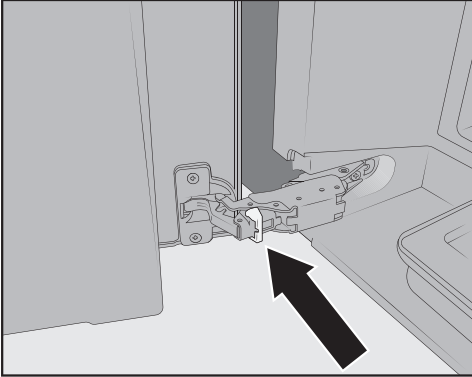

- Remove the door opening limiters from the hinges, e.g. by prising them out with a screwdriver.

The machine door opening angle has now been increased to approx. 170°.

Technical data

Electricity consumption in standby:	< 1.0 W
Electricity consumption in networked standby:	< 1.4 W
Frequency band of the WiFi module	2.4000 GHz – 2.4835 GHz
Maximum transmitting power of the WiFi module	< 100 mW

EU Conformity declaration

Miele hereby declares that this coffee machine complies with Directive 2014/53/EU.

The complete text of the EU declaration of conformity is available from one of the following internet addresses:

- Products, Download from www.miele.ie
- For service, information, operating instructions etc: go to <https://miele.co.uk/manuals> and enter the name of the product or the serial number

UK Conformity declaration

Miele hereby declares that this coffee machine complies with UK Radio Equipment Regulations 2017, as amended.

The complete text of the UK declaration of conformity is available from one of the following internet addresses:

- Products, Download from www.miele.co.uk
- For service, information, operating instructions etc: go to <https://miele.co.uk/manuals> and enter the name of the product or the serial number

UK Conformity declaration

This **Statement of Compliance** confirms this Miele product fully complies with the **Product Security and Telecommunications Infrastructure (Security Requirements for Relevant Connectable Products) Regulations 2023**.

- 1) Household Appliance – *Household coffee maker 392, 393, 395, 396, 503, 505*
- 2) Manufactured by: Miele & Cie KG,
Carl Miele Street 29, 33332 Gutersloh Germany
Imported by and contact point: Miele Company Ltd, Fairacres, Marcham Road,
Abingdon, Oxon, OX14 ITW Great Britain
- 3) The defined support period at the time of first supply is 10 years
- 4) To report vulnerabilities and cybersecurity issues please contact: psirt@miele.com

5) Signature 

Name: **Paul Wright**

Company Position: **Head of Technical Management**

Date of signature: **19th March 2024**

Place of signature: **Abingdon, Oxfordshire**

Copyrights and Licences

Miele uses their own and third party software which is not subject to any so-called Open Source Licence for the operation and control of the appliance. This software/ these software components are protected by copyright. The copyright powers of Miele and third parties have to be respected.

Furthermore, this appliance contains software components which are distributed under Open Source licence conditions. Please refer to [Settings | Legal information | Open Source licences](#) in the appliance for the Open Source components contained therein, together with the corresponding copyright notices, copies of the licence terms valid at the time, and any further information. The liability and warranty provisions of the Open Source licence terms and conditions as stated therein apply only in relation to the respective rights holders.

In particular, the appliance contains software components licenced by the copyright holders under the GNU General Public License, Version 2, or the GNU Lesser General Public License, Version 2.1. For a period of at least 3 years from the date of purchase or delivery of the appliance respectively, Miele offers to provide you or third parties with a machine-readable copy of the source code of the Open Source components contained in the appliance and licenced under the terms of the GNU General Public License, Version 2, or the GNU Lesser General Public License, Version 2.1, on a data carrier (CD-ROM, DVD or USB stick). Please contact us via e-mail (info@miele.com) or the below postal address and state the product name, the serial number and the date of purchase to obtain this source code.

Miele & Cie. KG
Open Source
GTZ/TIM
Carl-Miele-Straße 29
33332 Gütersloh

Please note the limited warranty in favour of the rights holders under the terms of the GNU General Public License, Version 2, and the GNU Lesser General Public License, Version 2.1:

This program is distributed in the hope that it will be useful, but WITHOUT ANY WARRANTY, without even the implied warranty of MERCHANTABILITY of FITNESS FOR A PARTICULAR PURPOSE. See the GNU General Public License and GNU Lesser General Public License for more details.

United Kingdom

Miele Co. Ltd., Fairacres, Marcham Road, Abingdon, Oxon, OX14 1TW
Tel: 0330 160 6600, Internet: www.miele.co.uk, E-mail: info@miele.co.uk

Australia

Miele Australia Pty. Ltd.
ACN 005 635 398
ABN 96 005 635 398
Level 4, 141 Camberwell Road
Hawthorn East, VIC 3123
Tel: 1300 464 353
E-mail: info@miele.com.au
Internet: www.miele.com.au

China Mainland

Miele Electrical Appliances Co., Ltd.
1-3 Floor, No. 82 Shi Men Yi Road
Jing' an District
200040 Shanghai, PRC
Tel: +86 21 6157 3500
Fax: +86 21 6157 3511
E-mail: info@miele.cn
Internet: www.miele.cn

Hong Kong, China

Miele (Hong Kong) Ltd.
41/F - 4101, Manhattan Place
23 Wang Tai Road
Kowloon Bay, Hong Kong
Tel: (852) 2610 1025
Fax: (852) 3579 1404
E-mail:
customerservices@miele.com.hk
Website: www.miele.hk

India

Miele India Pvt. Ltd.
1st Floor, Copia Corporate Suites,
Commercial Plot 9, Mathura Road,
Jasola, New Delhi - 110025
E-mail: customercare@miele.in
Website: www.miele.in

Ireland

Miele Ireland Ltd.
2024 Bianconi Avenue
Citywest Business Campus
Dublin 24
Tel: (01) 461 07 10
Fax: (01) 461 07 97
E-mail: info@miele.ie
Internet: www.miele.ie

Malaysia

Miele Sdn Bhd
Suite 12-2, Level 12
Menara Sapura Kencana
Petroleum
Solaris Dutamas No. 1
Jalan Dutamas 1
50480 Kuala Lumpur, Malaysia
Phone: +603-6209-0288
Fax: +603-6205-3768

New Zealand

Miele New Zealand Limited
IRD 98 463 631
8 College Hill
Freemans Bay, Auckland 1011
Tel: 0800 464 353
E-mail: customercare@miele.co.nz
Internet: www.miele.co.nz

Singapore

Miele Pte. Ltd.
29 Media Circle
#11-04 ALICE@Mediapolis
Singapore 138565
Tel: +65 6735 1191
Fax: +65 6735 1161
E-mail: info@miele.com.sg
Internet: www.miele.sg

South Africa

Miele (Pty) Ltd.
63 Peter Place, Bryanston 2194
P.O. Box 69434, Bryanston 2021
Tel: (011) 875 9000
Fax: (011) 875 9035
E-mail: info@miele.co.za
Internet: www.miele.co.za

Thailand

Miele Appliances Ltd.
BHIRAJ TOWER at EmQuartier
43rd Floor Unit 4301-4303
689 Sukhumvit Road
North Klongton Sub-District
Vadhana District
Bangkok 10110, Thailand

United Arab Emirates

Miele Appliances Ltd.
Showroom 1, Eiffel 1 Building
Sheikh Zayed Road, Umm Al Sheif
P.O. Box 114782 - Dubai
Tel. +971 4 3044 999
Fax. +971 4 3418 852
800-MIELE (64353)
E-mail: info@miele.ae
Website: www.miele.ae

Manufacturer: Miele & Cie. KG, Carl-Miele-Straße 29, 33332 Gütersloh, Germany

CVA 7840

en-GB

M.-Nr. 11 860 314 / 00