

en-GB - Installation drawings for fully integrated dishwashers

To avoid the risk of accidents or damage to the dishwasher please observe this installation sheet and read the operating instruction manual supplied with it before it is installed or used for the first time.

zh-CN - 60 厘米宽全嵌式洗碗机安装指示图

请于安装和首次使用前仔细阅读本安装简表及随附的操作说明书，以防发生意外或损坏本机。

zh-HK - 60 厘米宽嵌入式洗碗機安裝指示圖

請於安裝和首次使用之前仔細閱讀本安裝簡表及隨附之操作說明書，以防發生意外或損壞本機。

ko-KR - 60 cm 너비 완전 빌트인 식기세척기 설치도면

사고 또는 기기 손상의 위험을 방지하기 위해 설치도면을 잘 확인 후 설치하시고, 처음 사용하기 전에 함께 제공된 사용설명서를 반드시 읽어보시기 바랍니다.

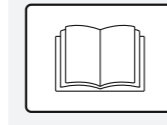

See operating instruction manual.

請閱讀操作說明書。
請參閱操作說明書。

사용설명서를 반드시 확인하세요.



Risk of damage or fire hazard.

謹防損壞或火災危險。
慎防損壞或火災危險。
손상 또는 화재의 위험.



Check connection data.

檢查電壓、連接負荷及功率。
檢查電壓、接駁負載及頻率。
전압, 전기용량, 주파수를 확인하세요.

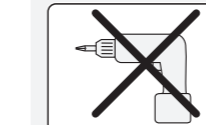

Do not use a cordless screwdriver, risk of damage.

不要使用充電螺絲刀，有損壞風險。
請勿使用無線螺絲批，否則可能造成損害。
무선 드라이버를 사용하지 마십시오. 손상의 위험이 있습니다.



Warning: Danger of being cut.

警告：謹防割傷。
注意事項：慎防割傷。
경고: 손이 베일 위험이 있음.



The minimum/maximum weight of the front panel is quoted in the technical data for your dishwasher on the Miele website.

Miele 網站上的洗碗機技術數據中註明了前面板的最小/最大重量。

Miele 網站上的洗碗機技術資料中註明了前面板的最小/最大重量。

전면부 패널의 최대/최소 무게는 밀레 웹사이트에 있는 식기세척기의 기술 데이터에 명시되어 있습니다.



The door springs must be set equally on both sides after fitting the front panel to the door.

將前面板安裝到機門上後，務必調整兩邊機門彈簧，確保兩邊彈簧鬆緊一致。

將前面板安裝到機門上後，必須調整兩邊機門彈簧，確保兩邊彈簧鬆緊一致。

가구 도어를 부착한 후, 도어가 원활하게 닫힐 수 있도록 도어의 스프링 나사를 움직여 수평을 조절하세요.



Screw the feet in before moving the dishwasher.

搬運洗碗機前，請旋緊腳架。

搬運洗碗機前，旋緊腳架。

식기세척기를 고정하기 전에 받침대 나사를 이용해서 바닥 수평을 조절하세요.

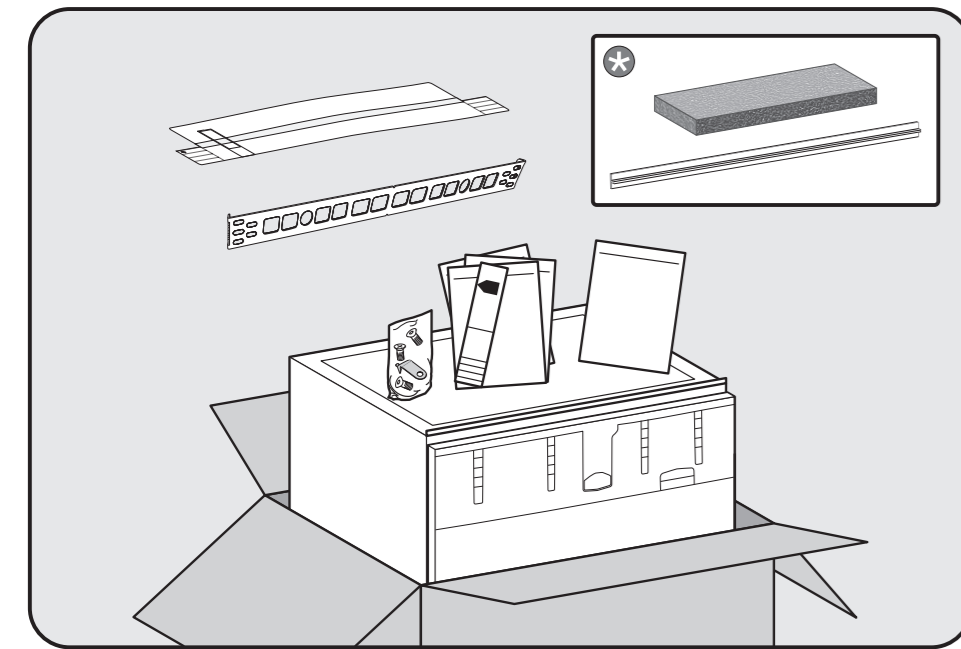

Fittings supplied depend on model.
根據型號提供配件。
提供的配件視型號而定。
제공되는 피팅은 모델에 따라 다릅니다.

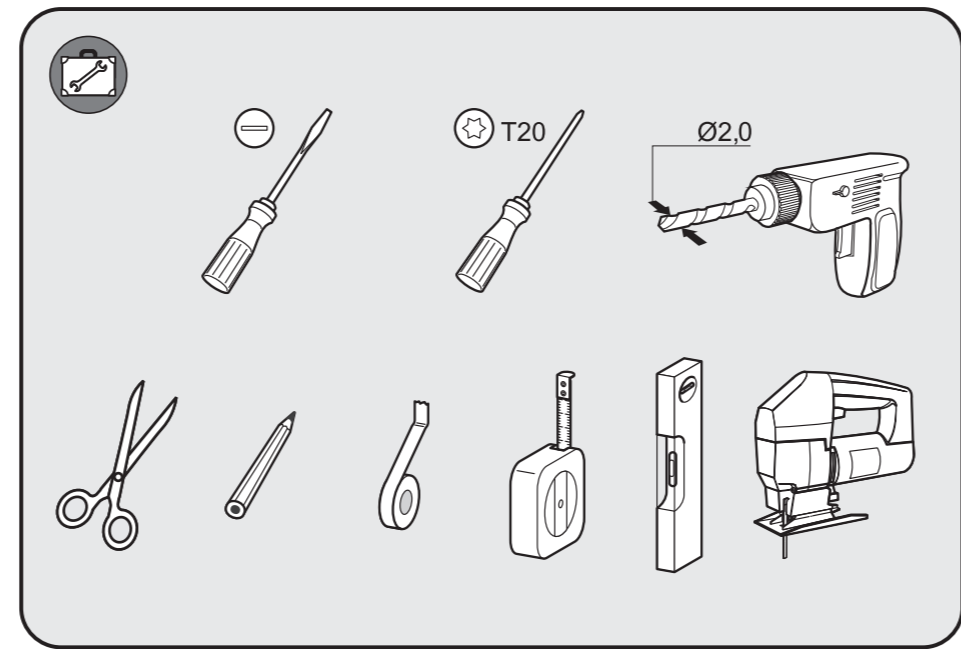
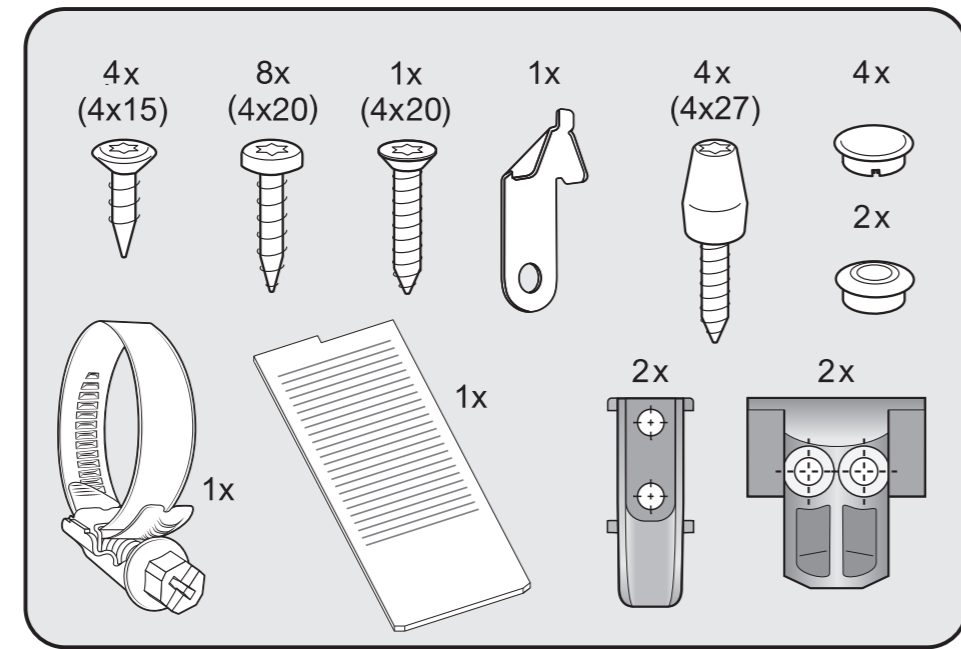

Tools required depend on model.
所需工具視型號而定。
需要的工具視型號而定。
필요한 도구는 모델에 따라 다릅니다.

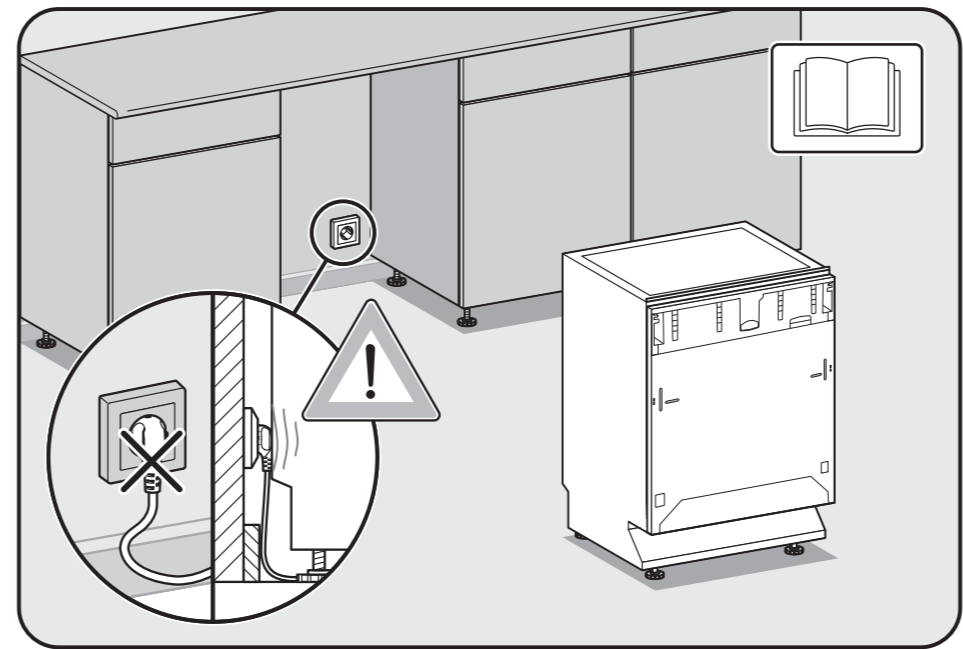

Venting the water drain

If the on-site drainage connection is situated lower than the guide path for the lower basket rollers in the open door, the drainage system must be vented.

疏通排水

如果在打开机门的情况下，现场排水管接口的位置低于下层篮架滚轮的引导路径，则排水系统必须排气。

為排水系統排氣

如果在打開機門時現場排水連接位於下層籃架滾輪的導向槽下方，則必須為排水系統排氣。

배수를 위한 통풍

현장 배수 연결이 열린 도어의 하단 바스켓 롤러 보다 낮은 경우, 배수를 위해 세척실 내 통풍구 환기가 필요합니다.

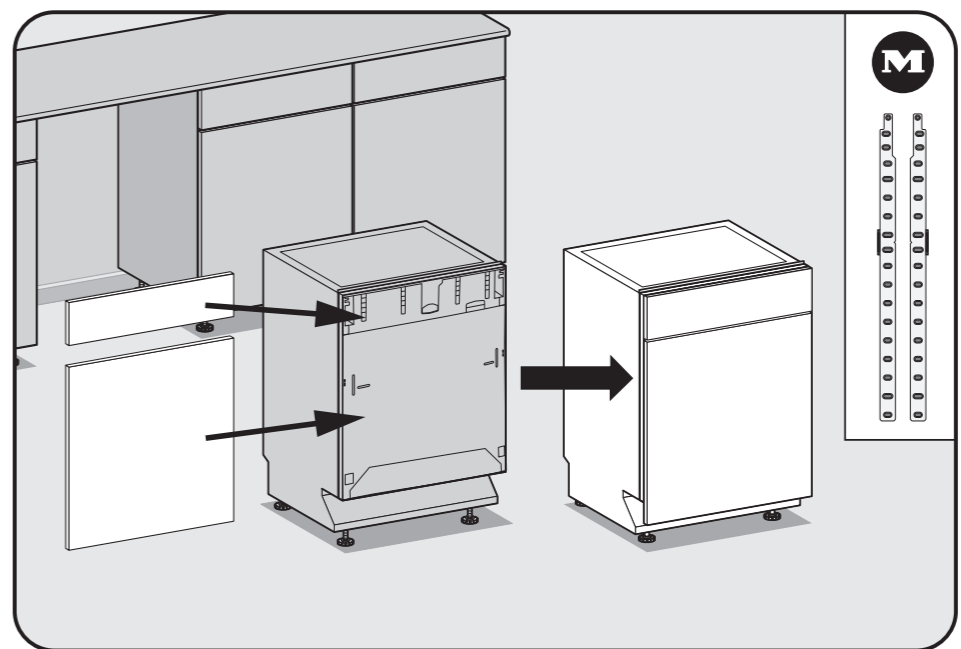
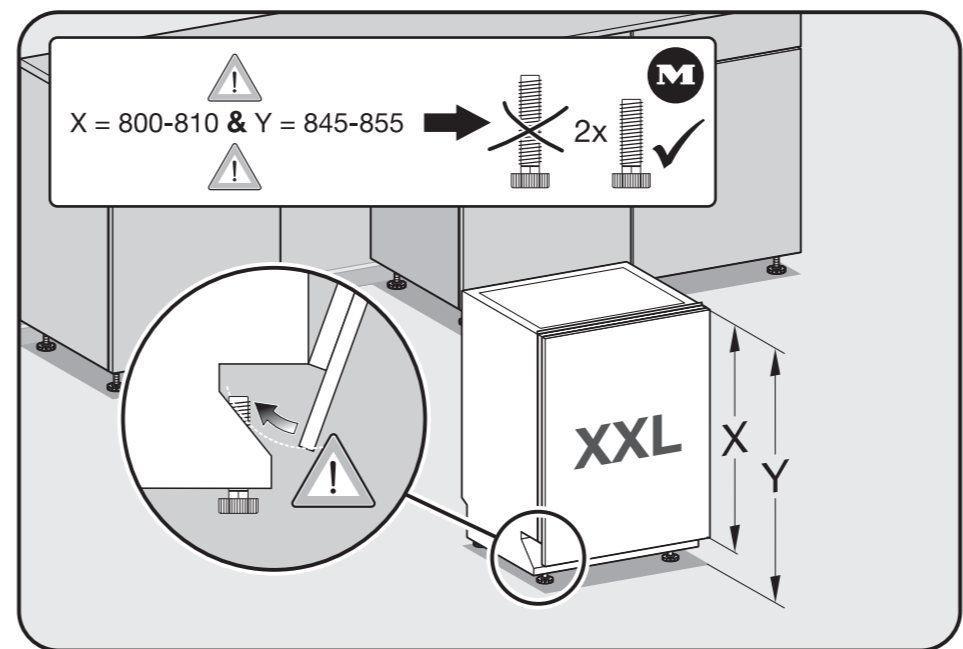
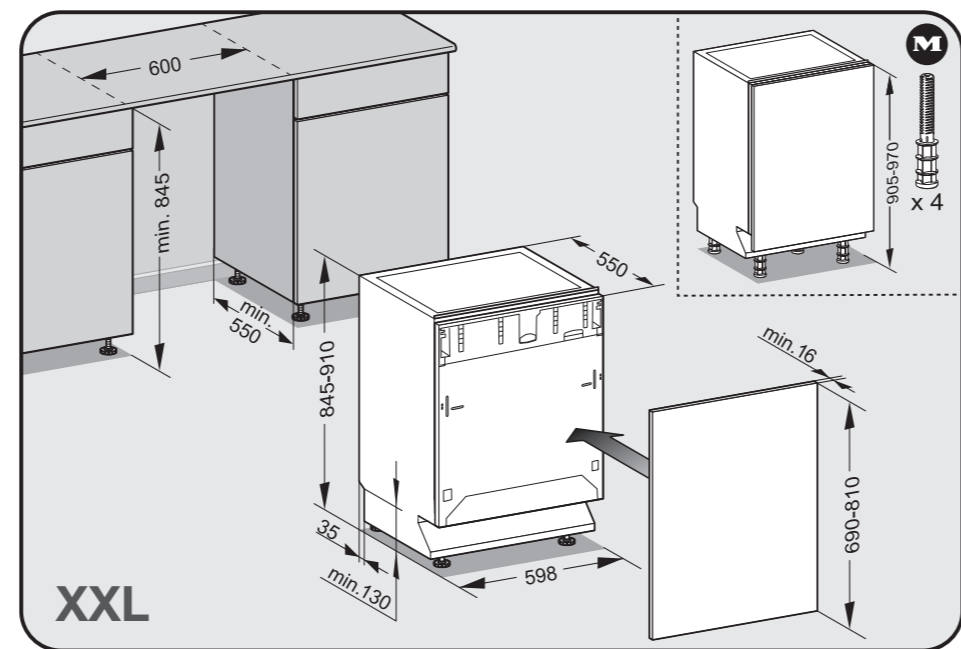
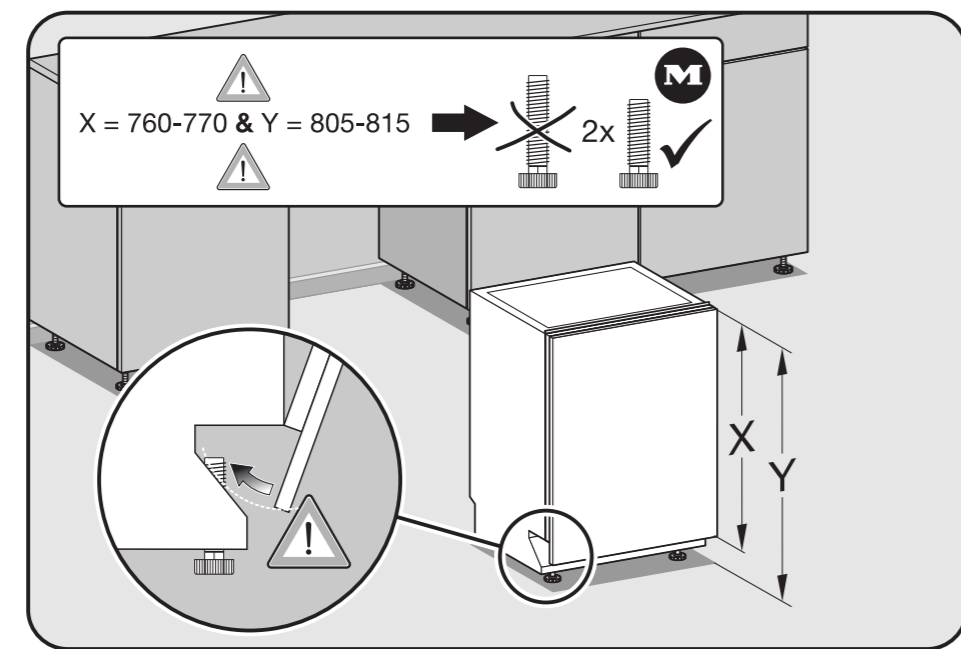
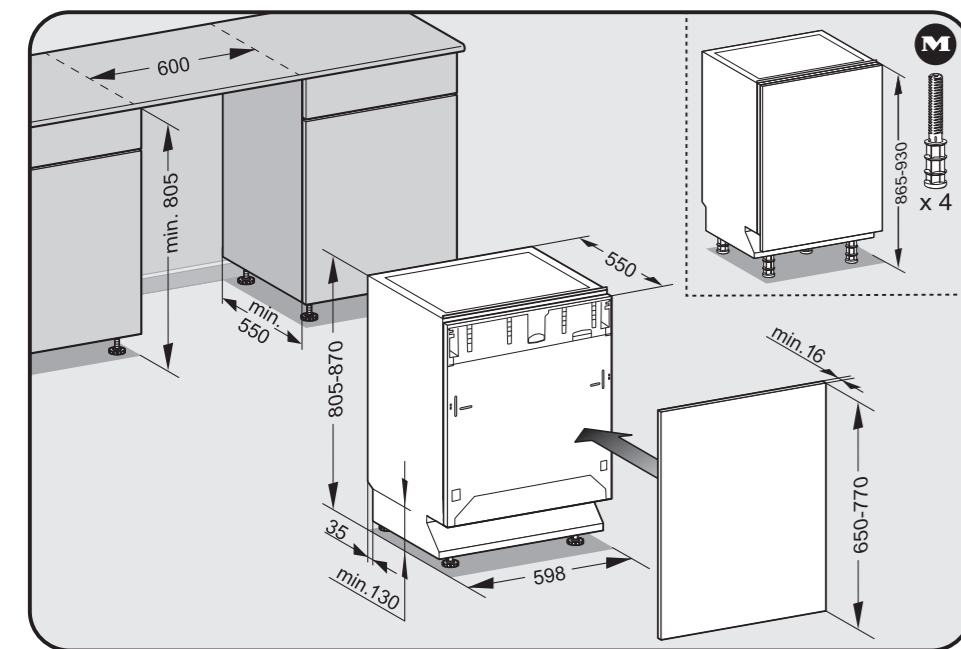

M
Optional accessory
可選配件
自選配件
추가 약세서리



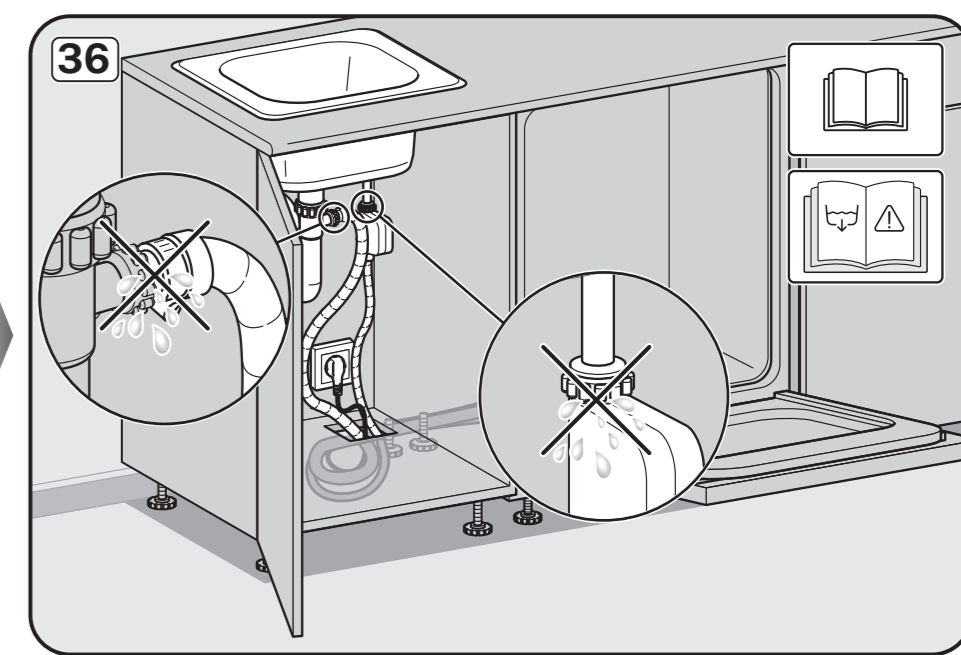
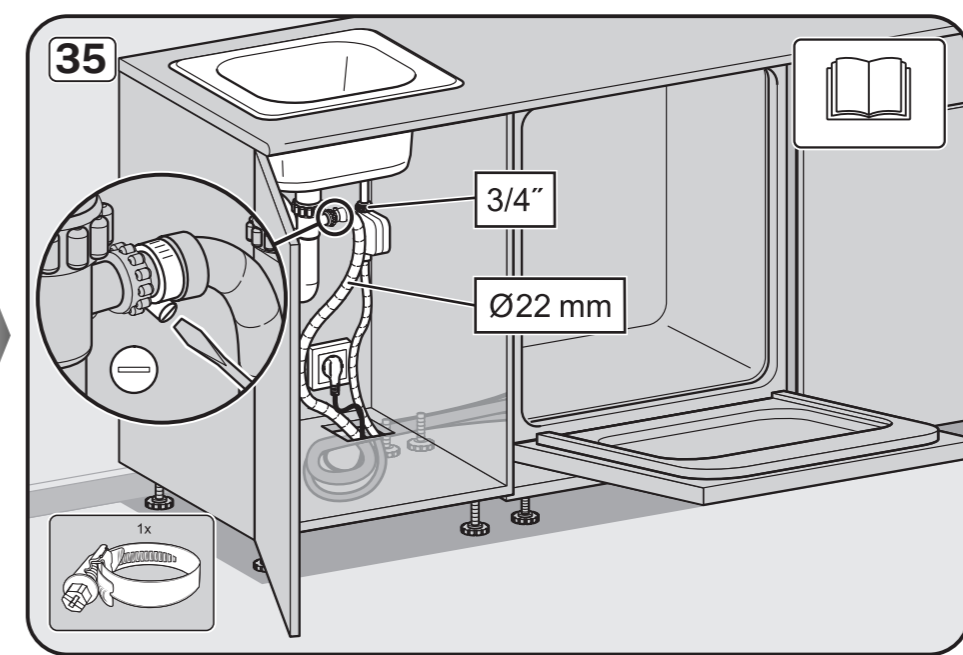
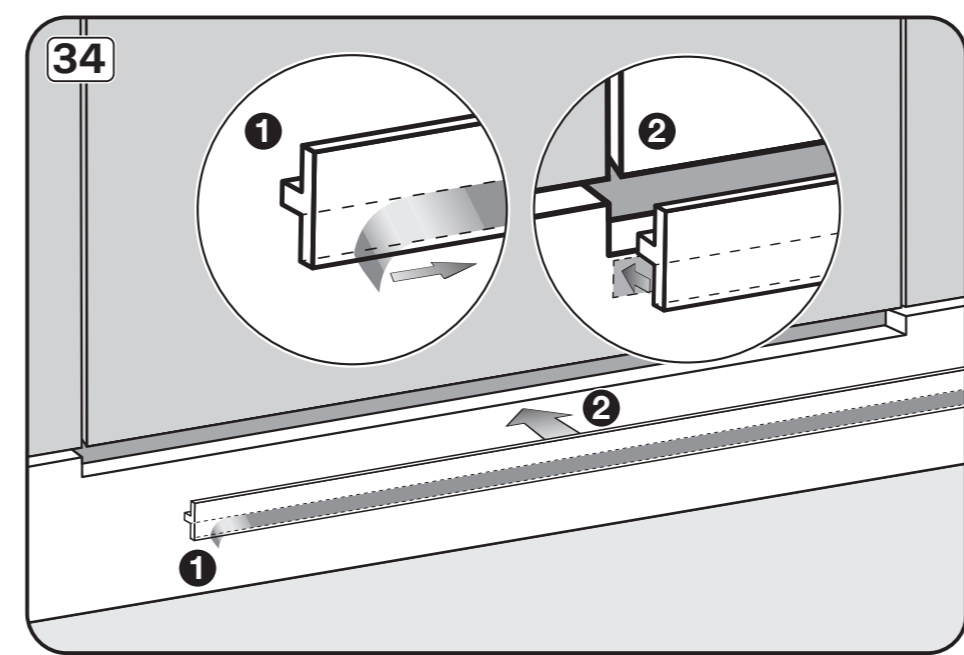
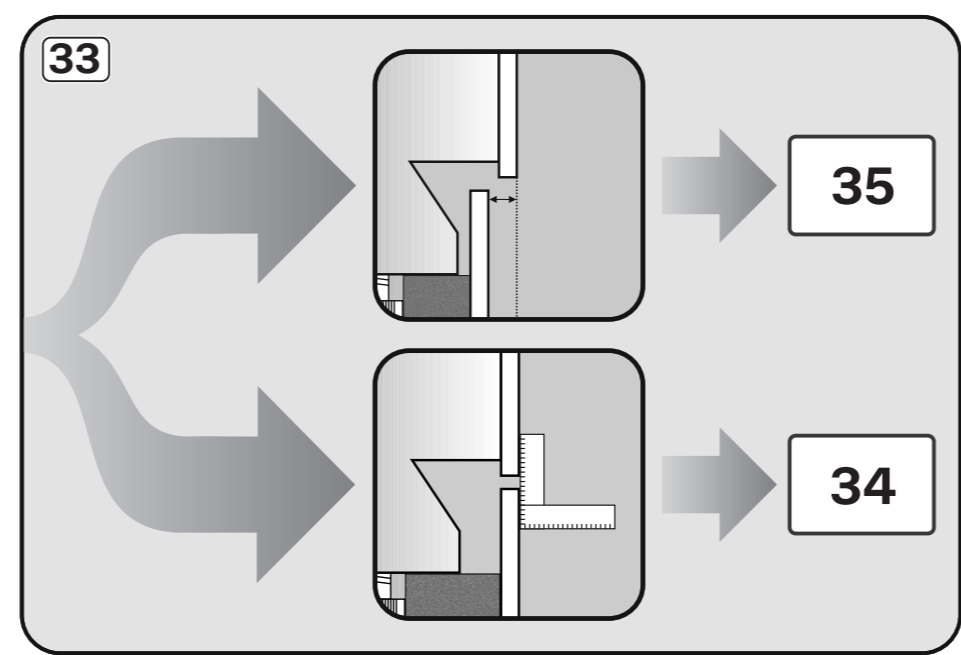
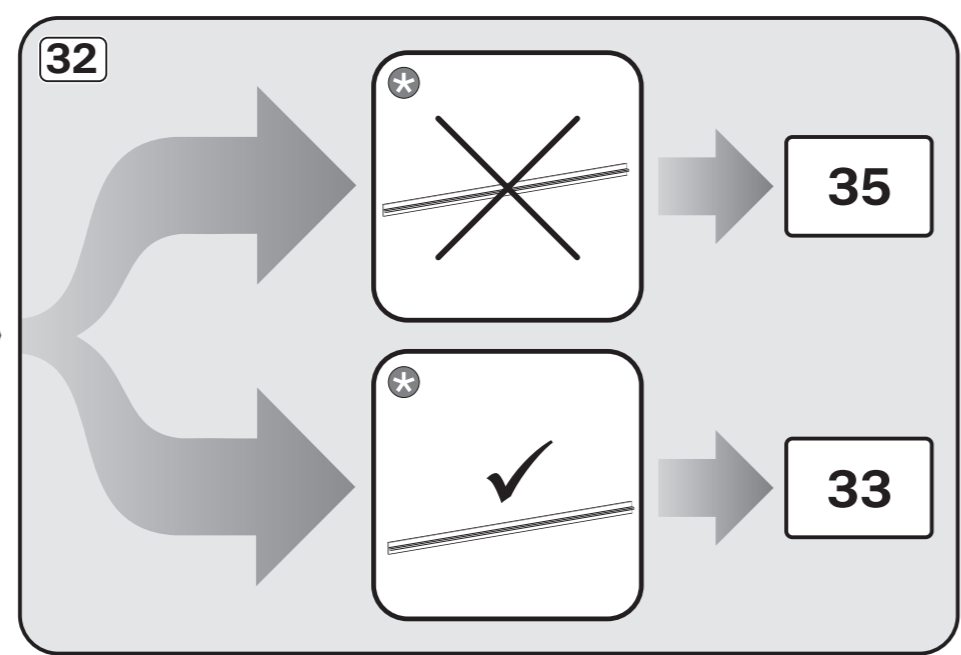
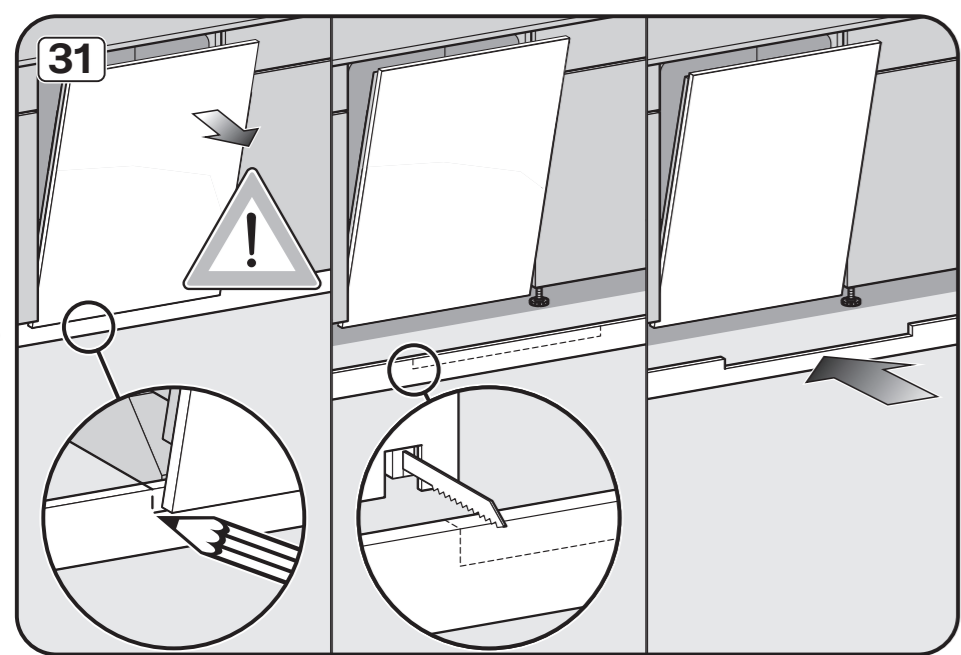
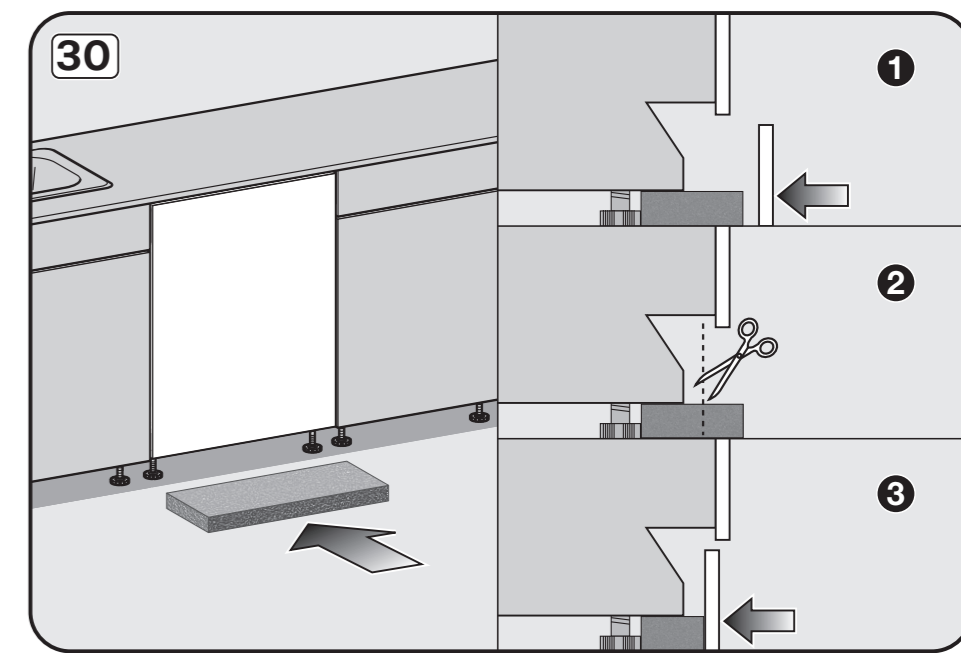
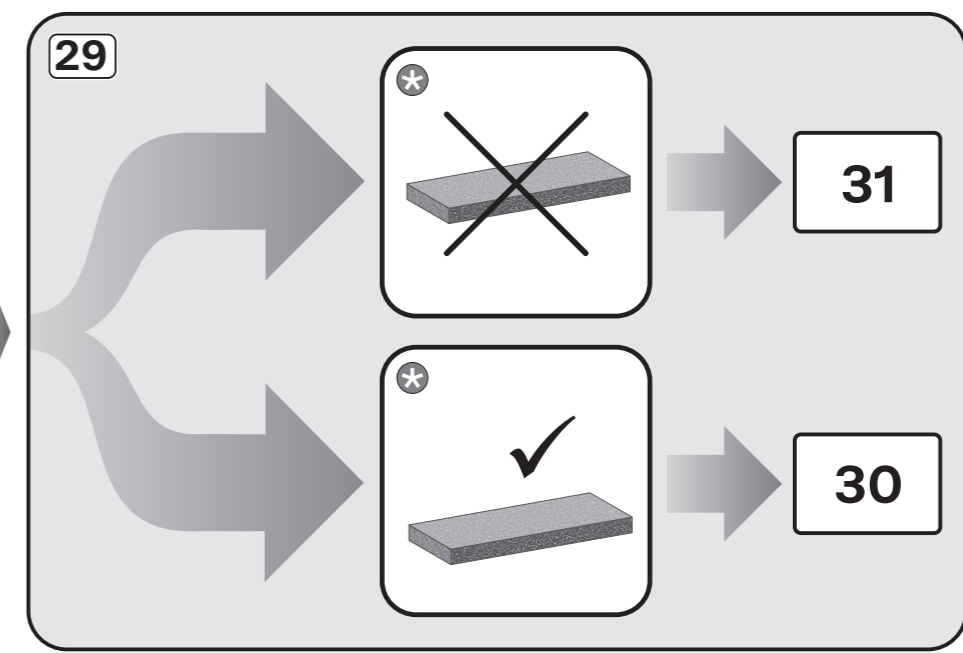
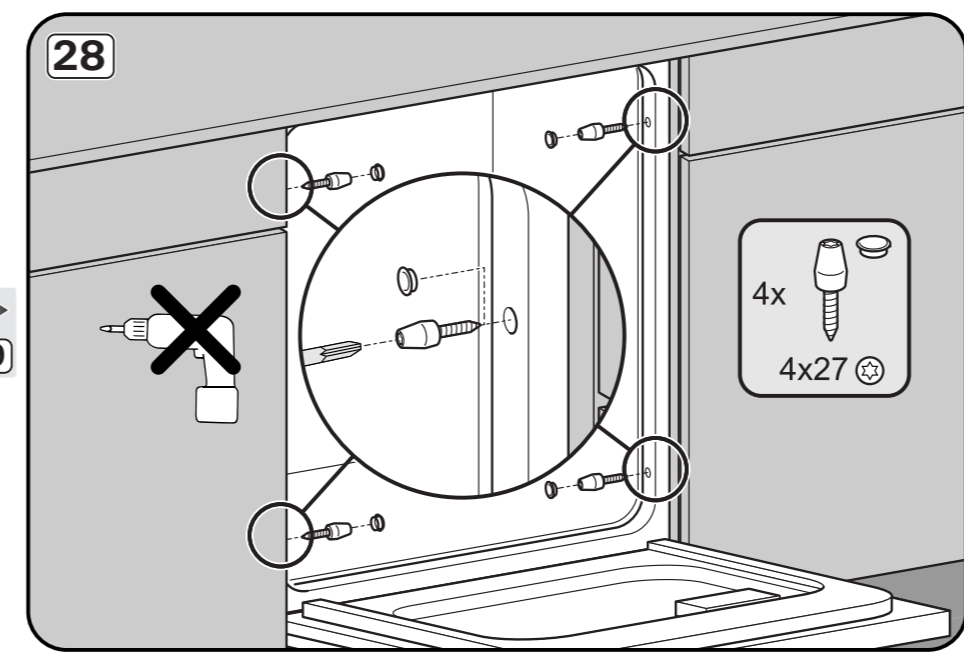
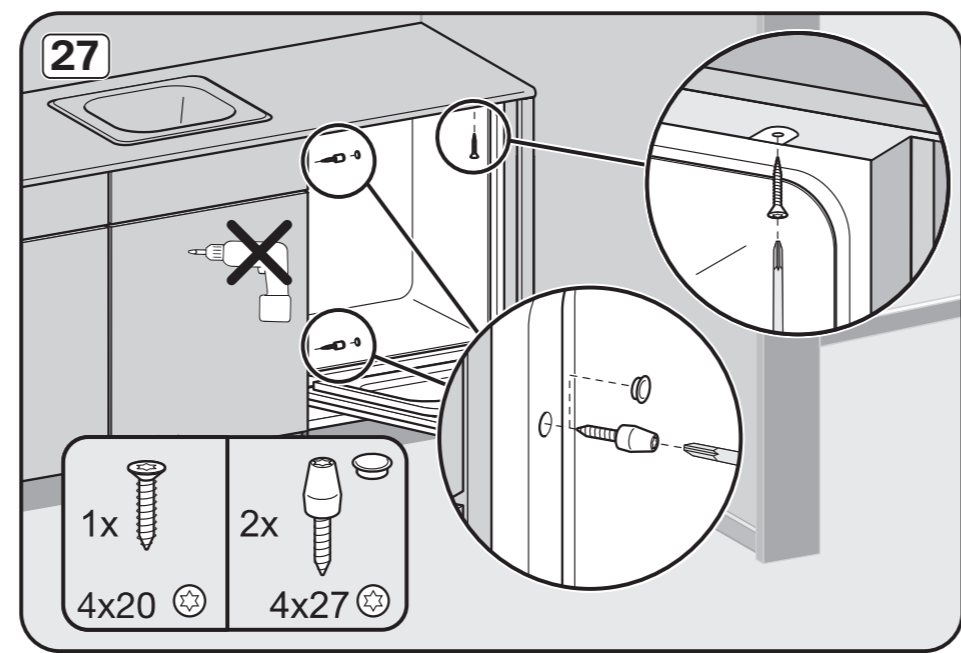
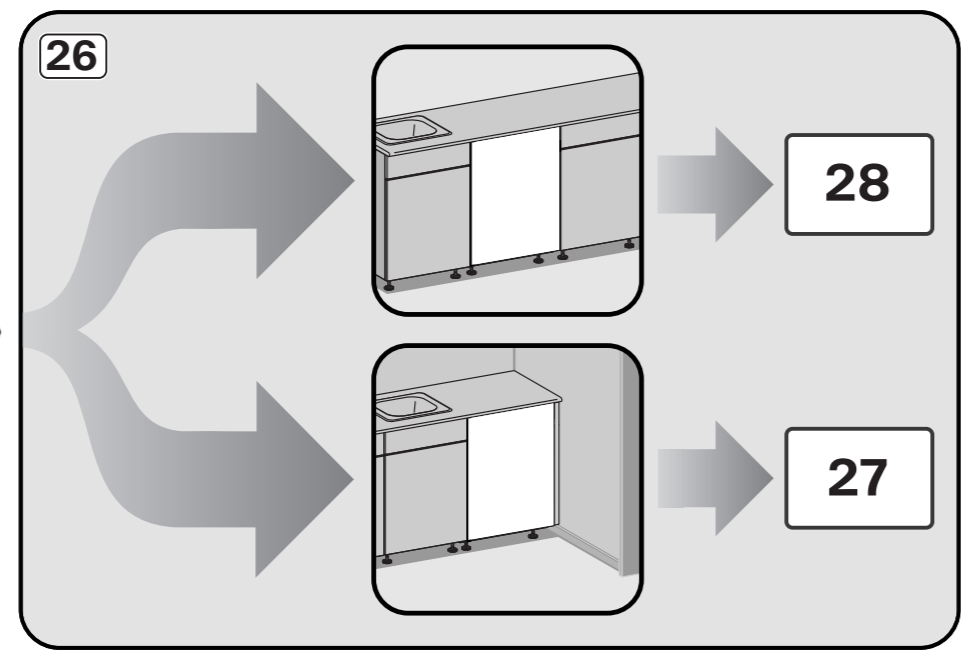
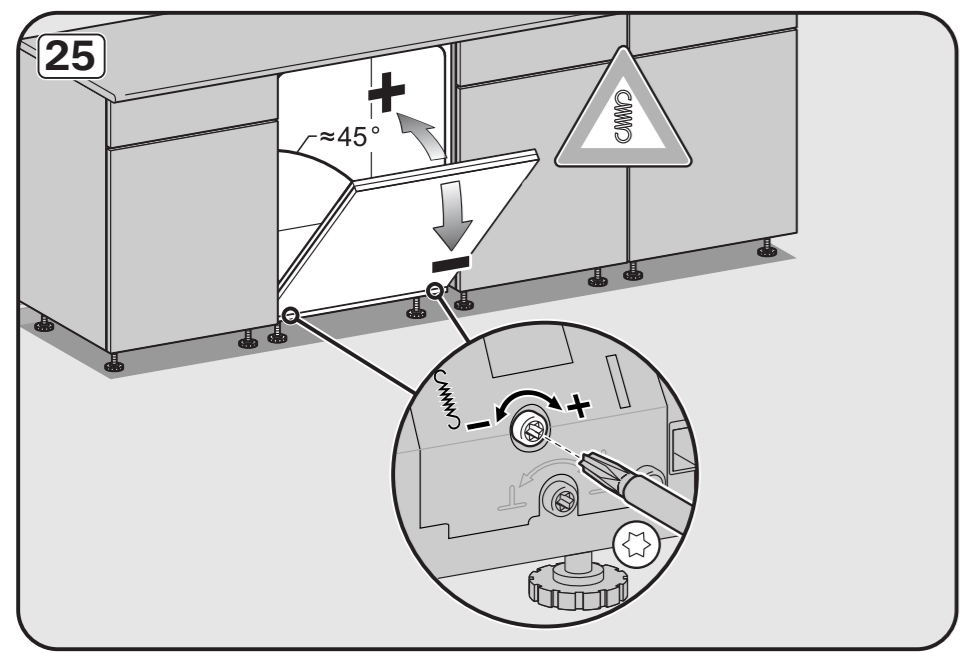
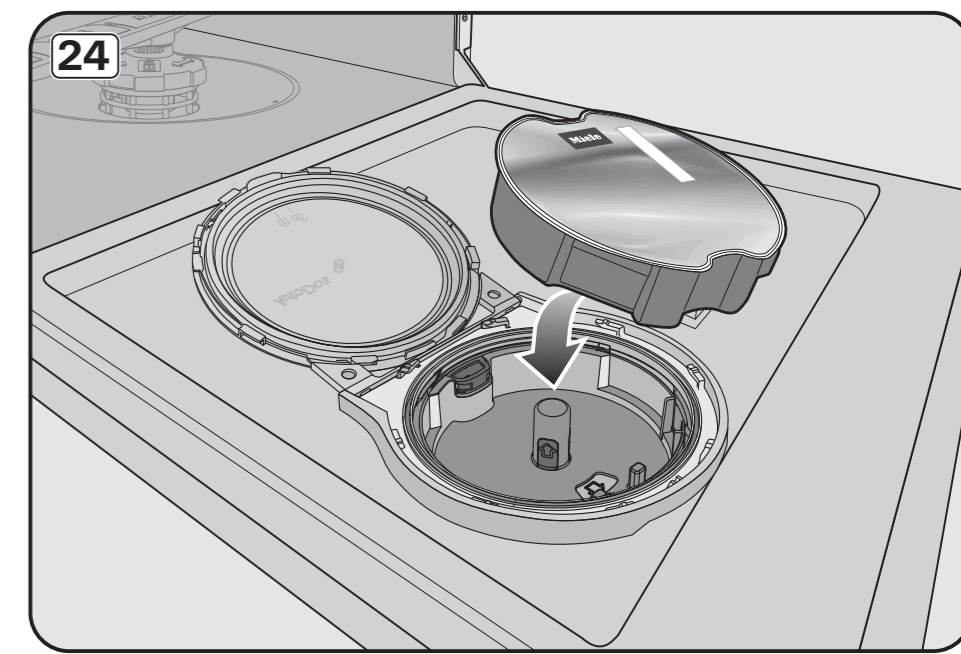
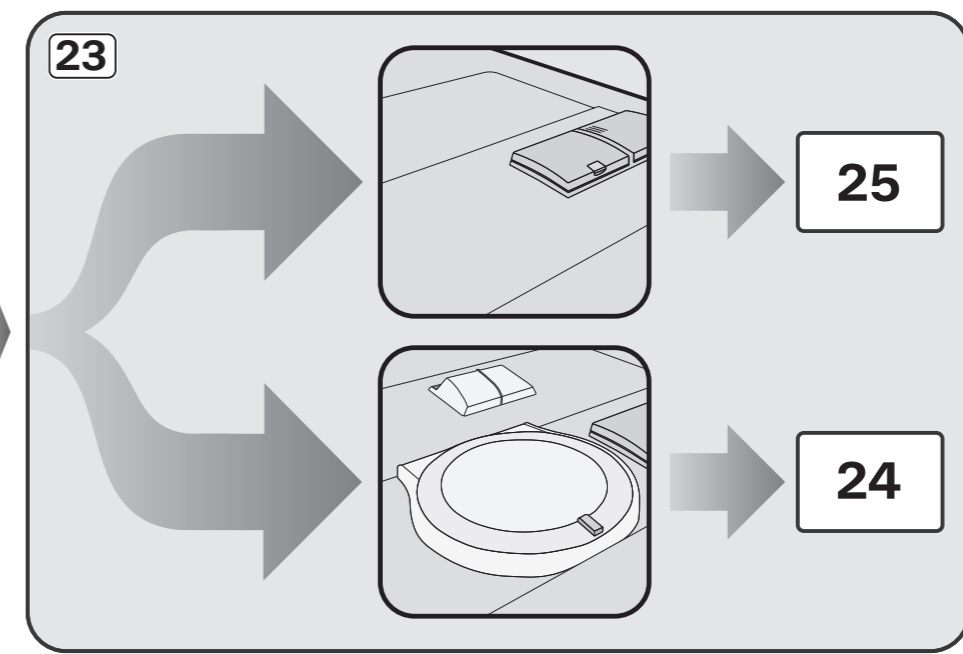
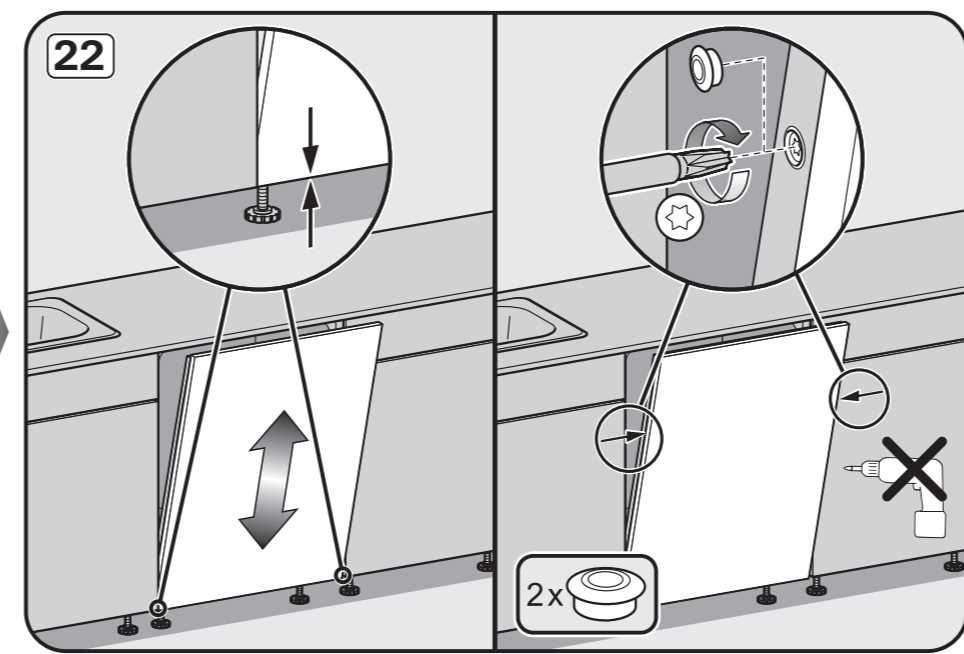
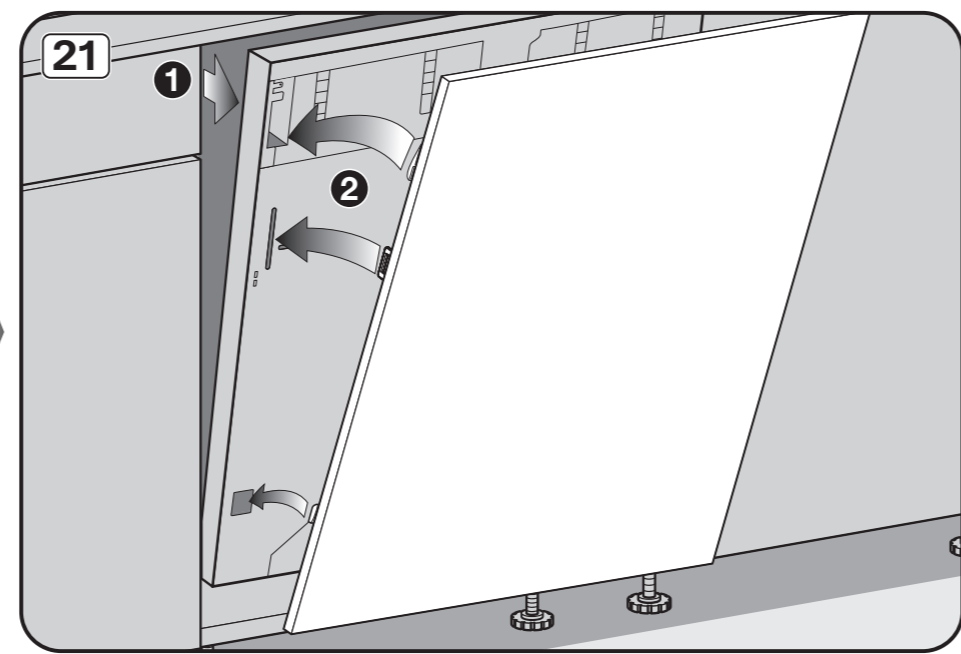
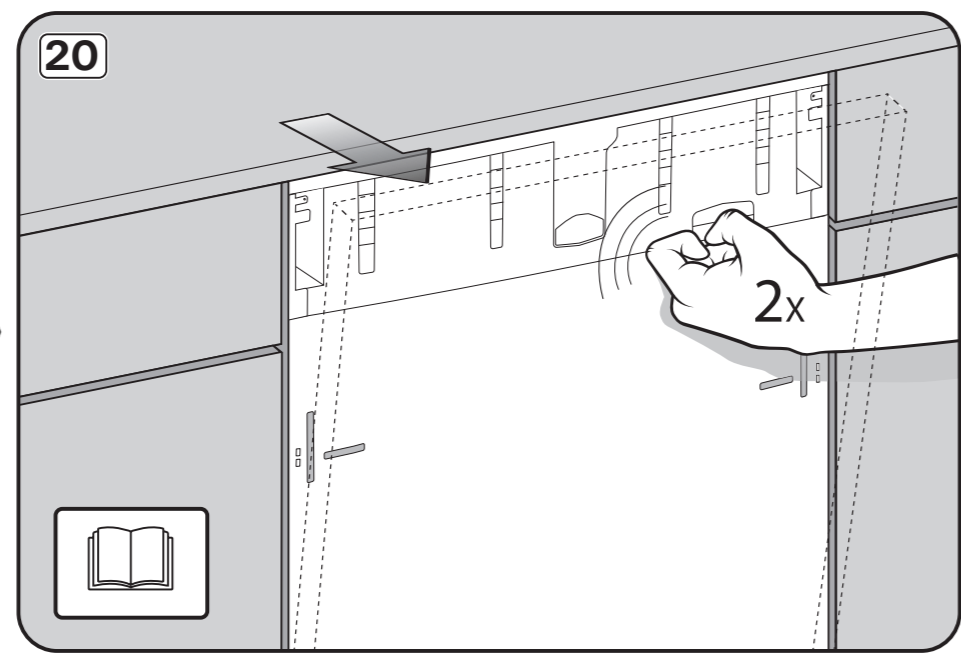
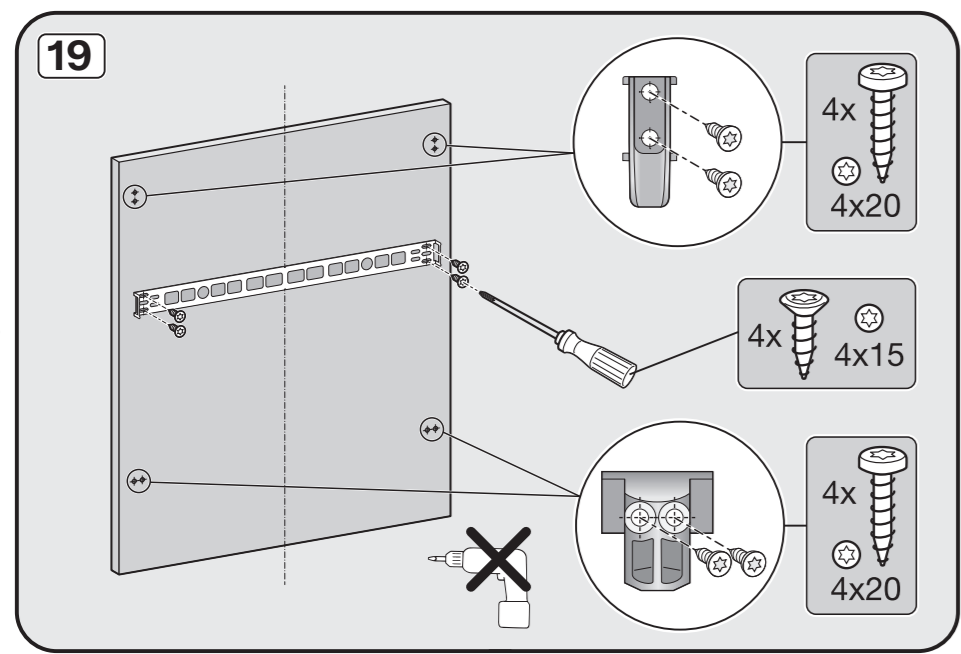
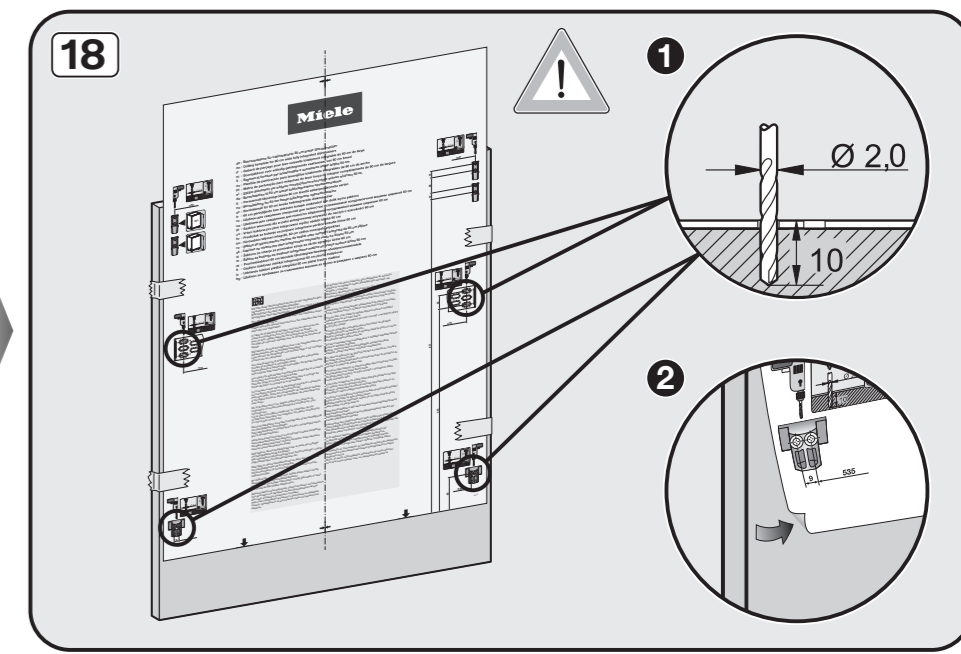
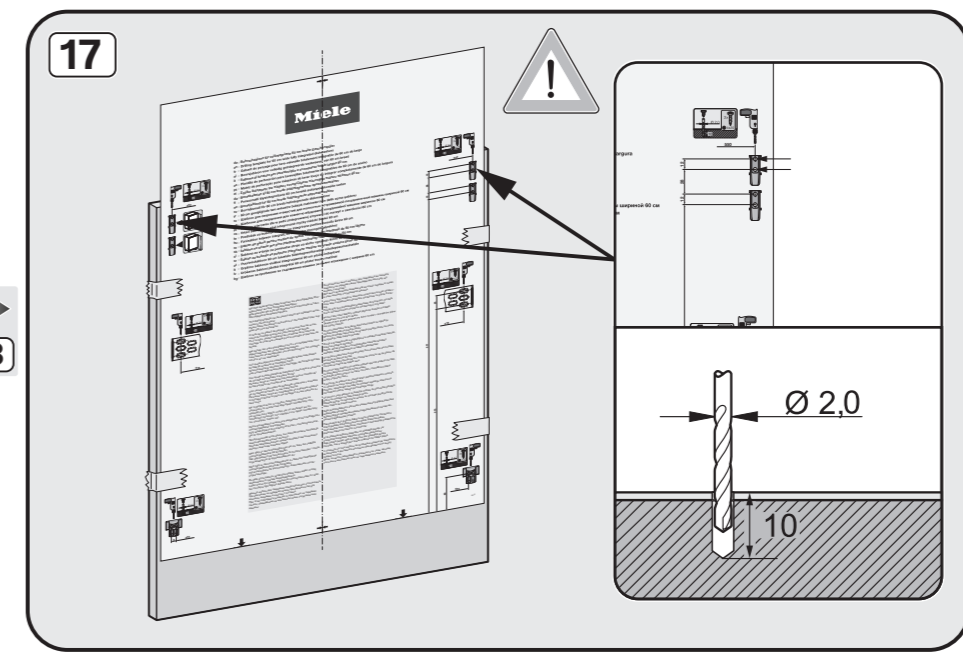
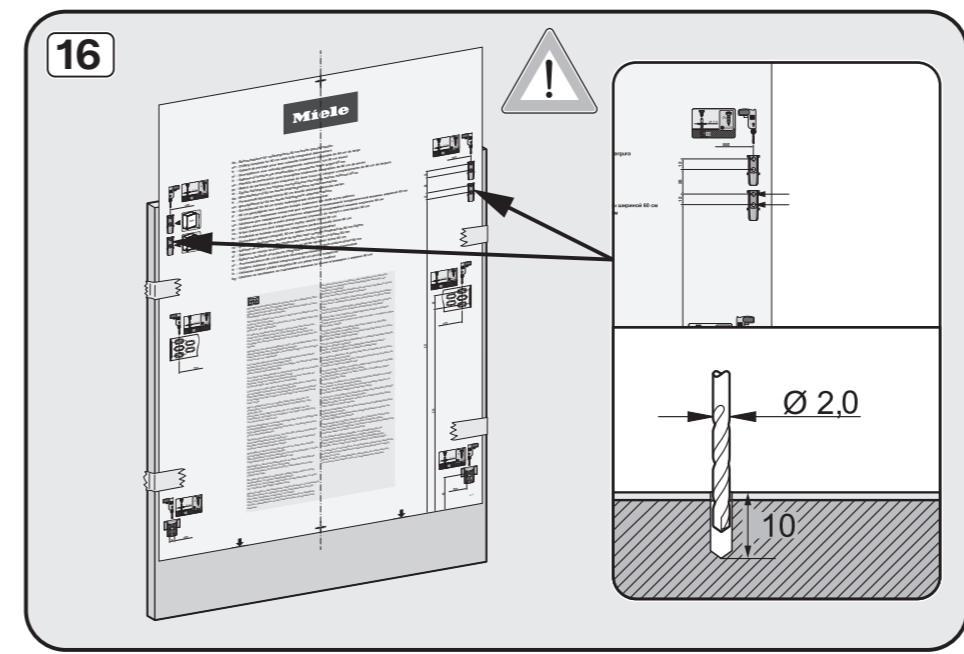
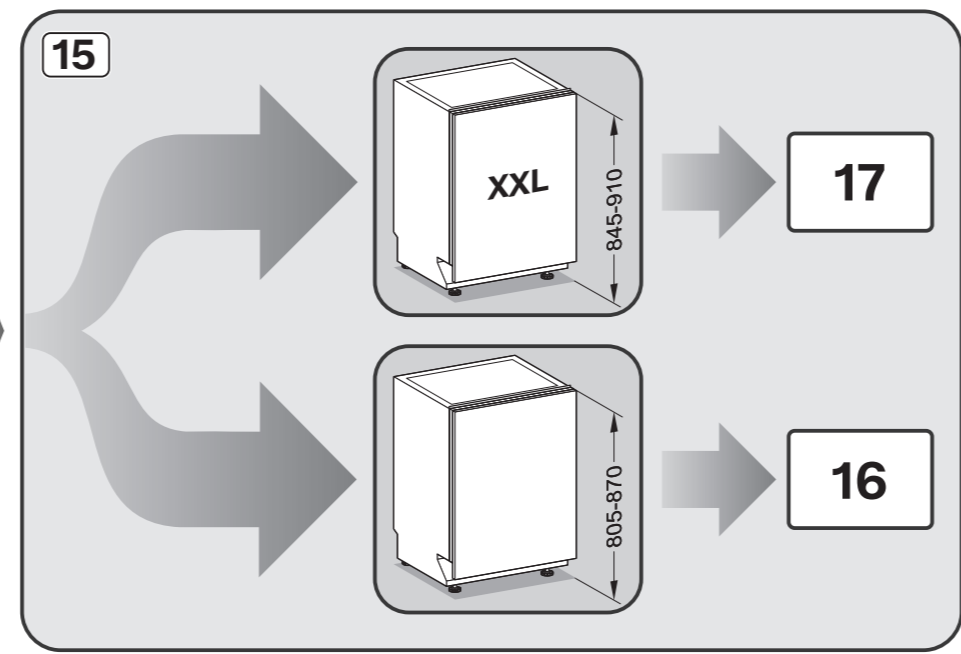
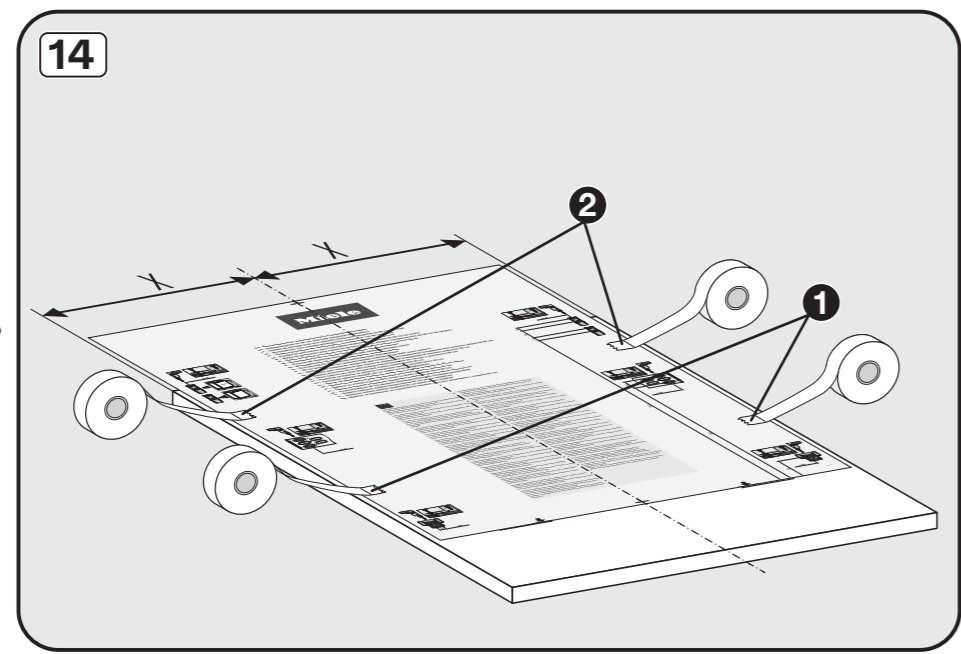
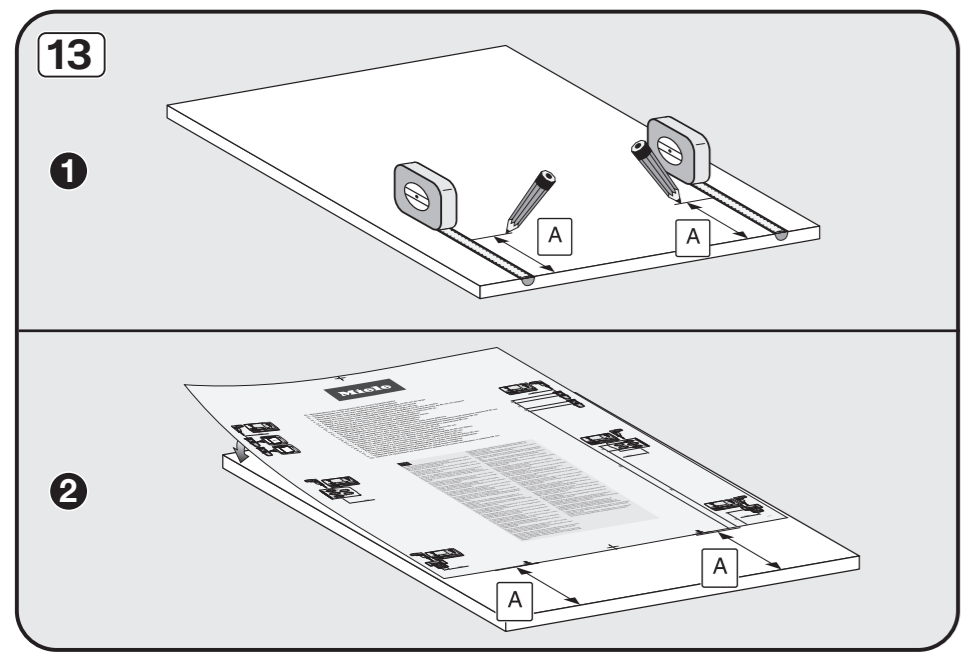
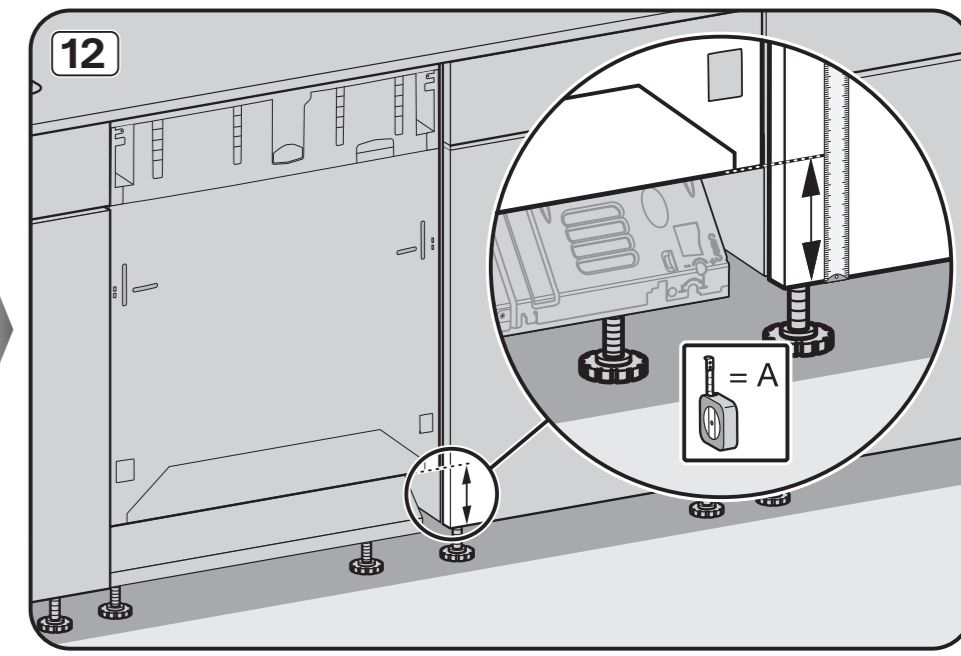
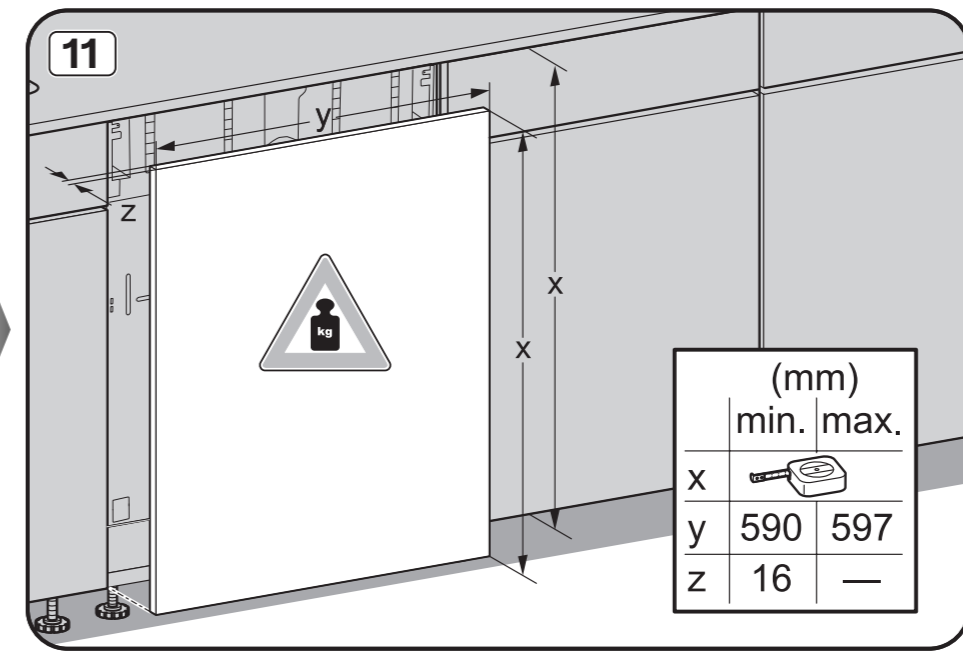
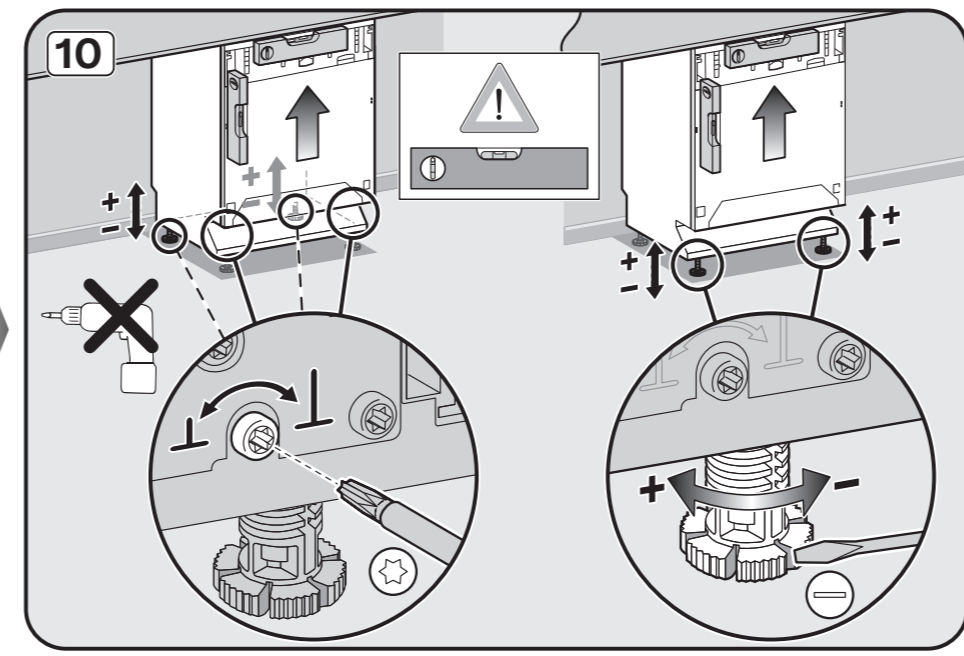
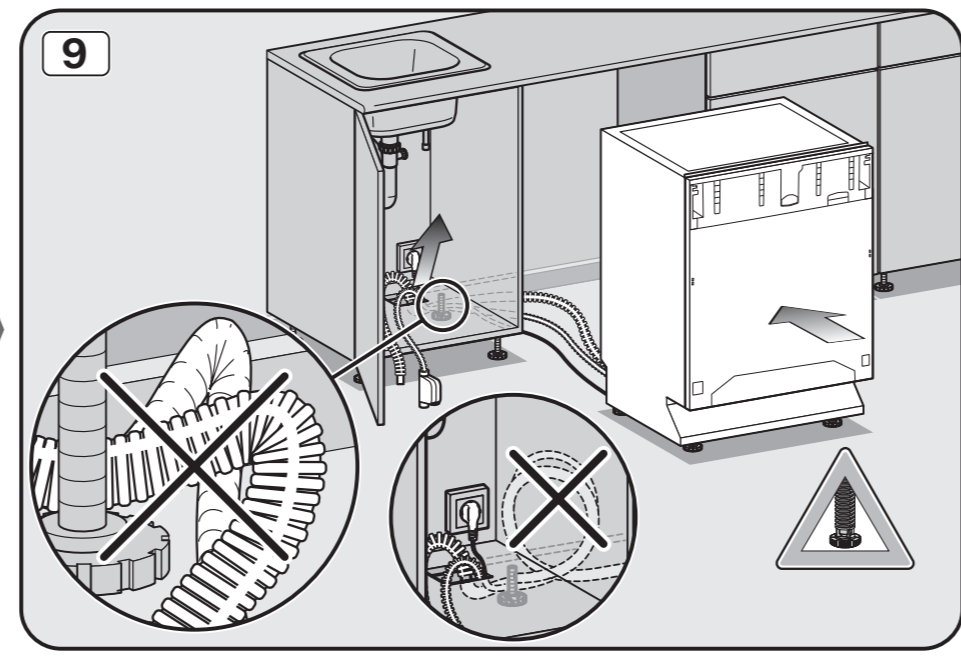
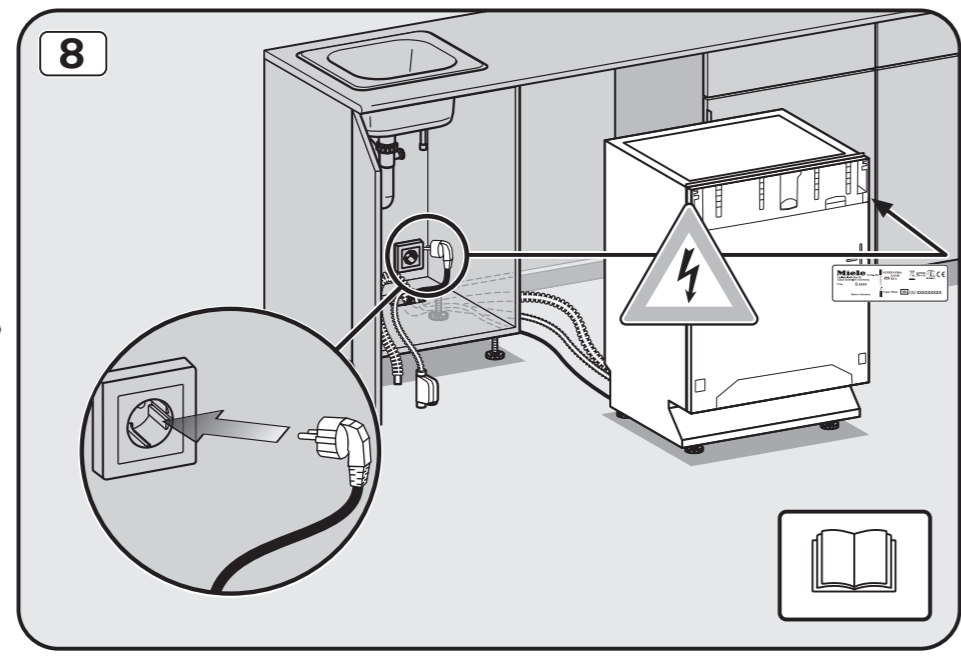
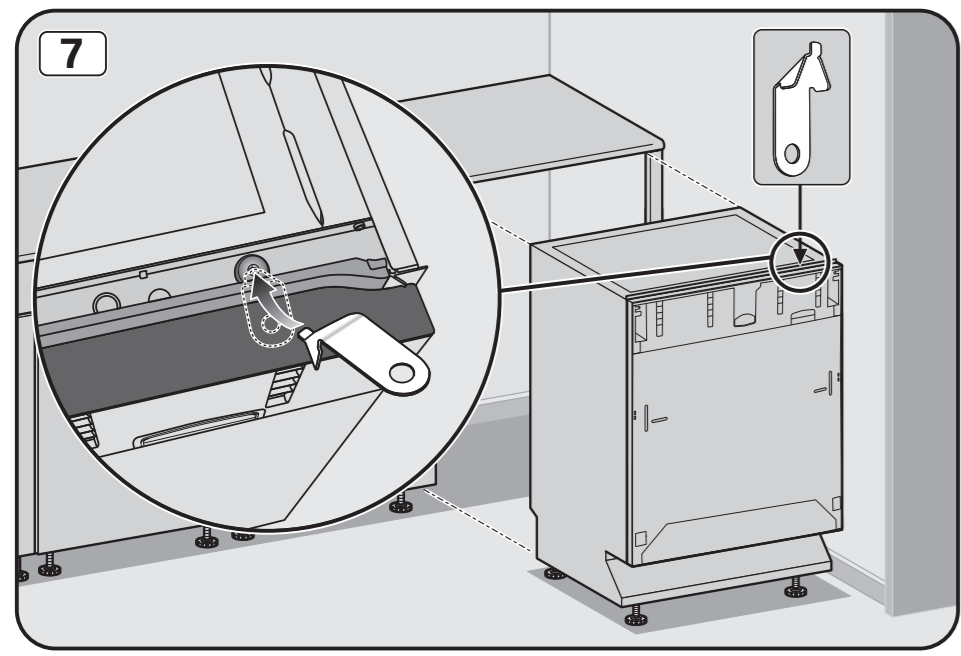
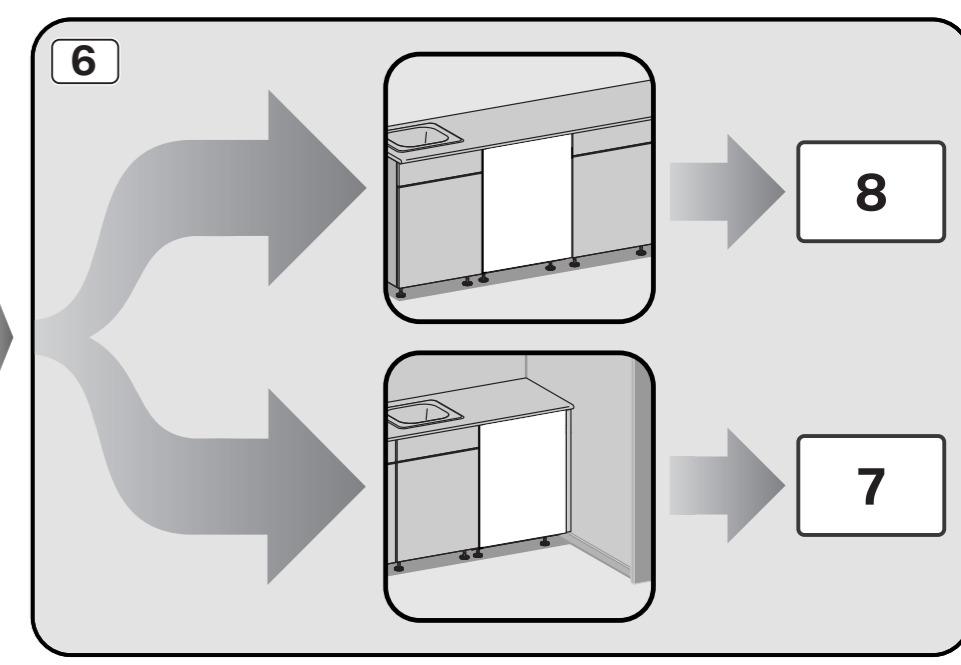
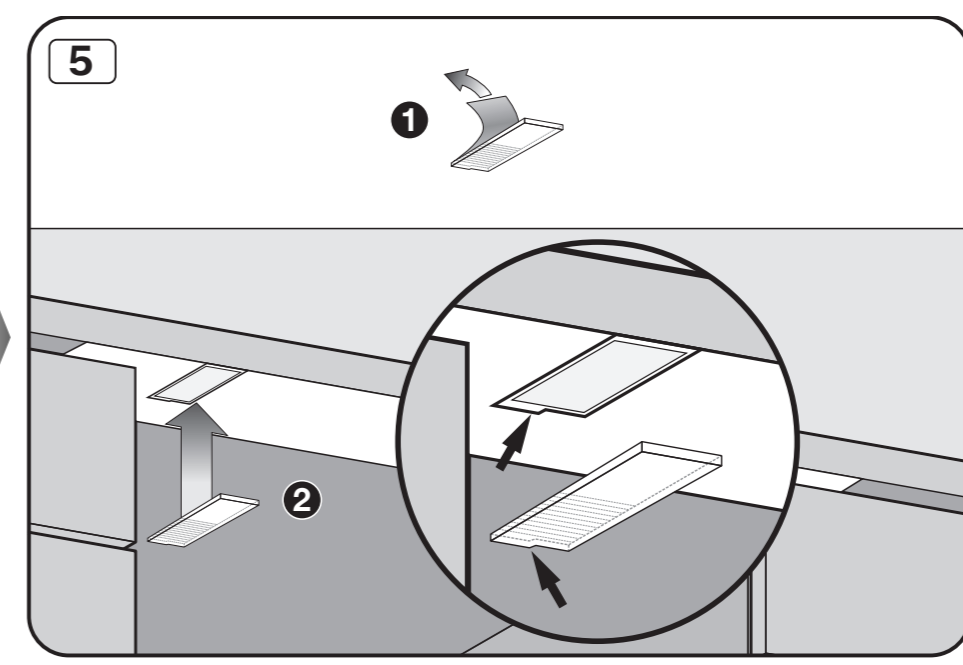
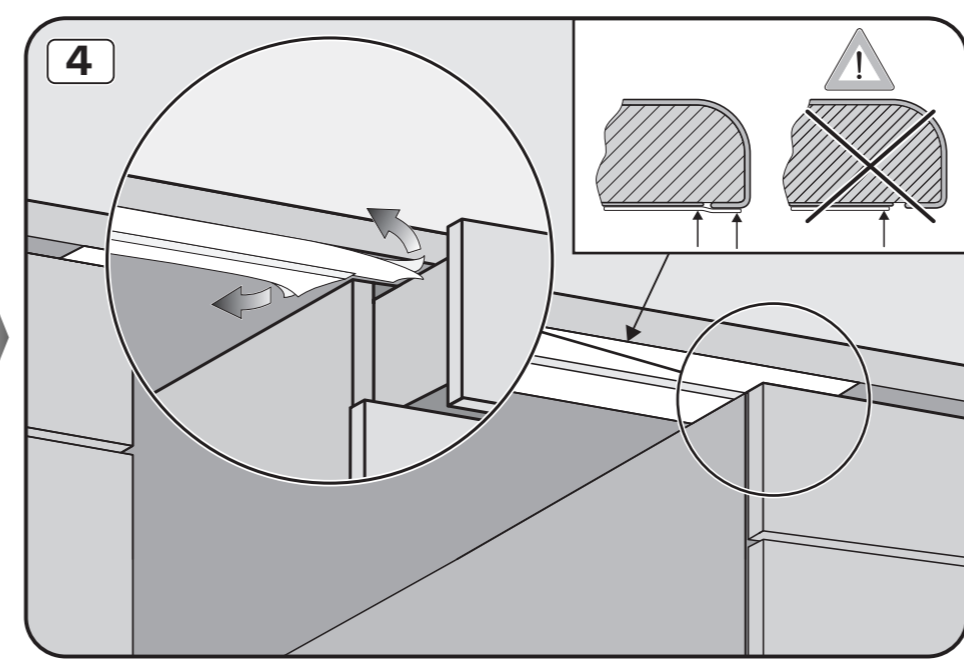
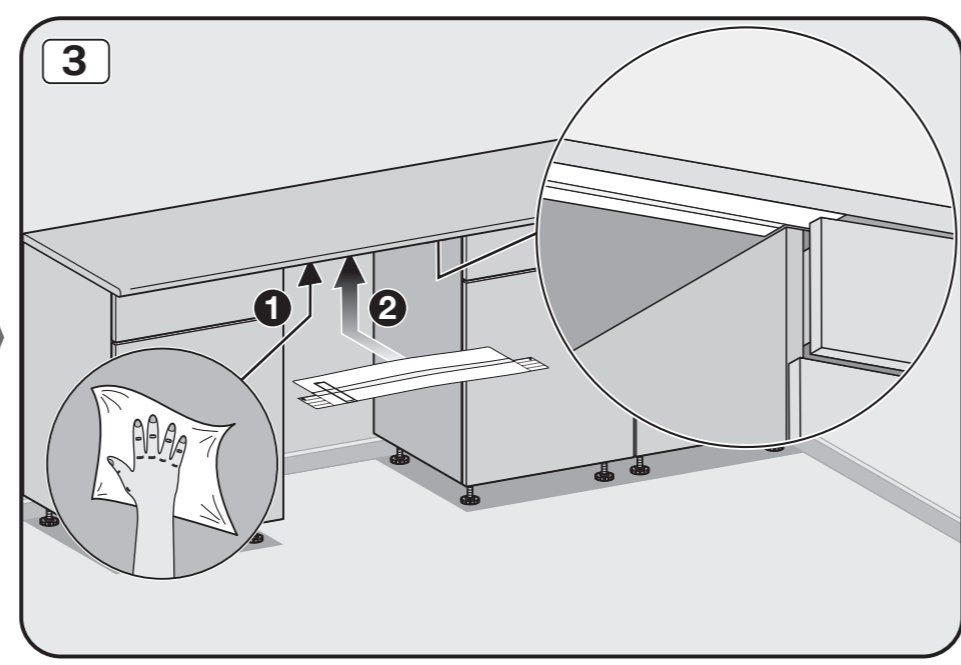
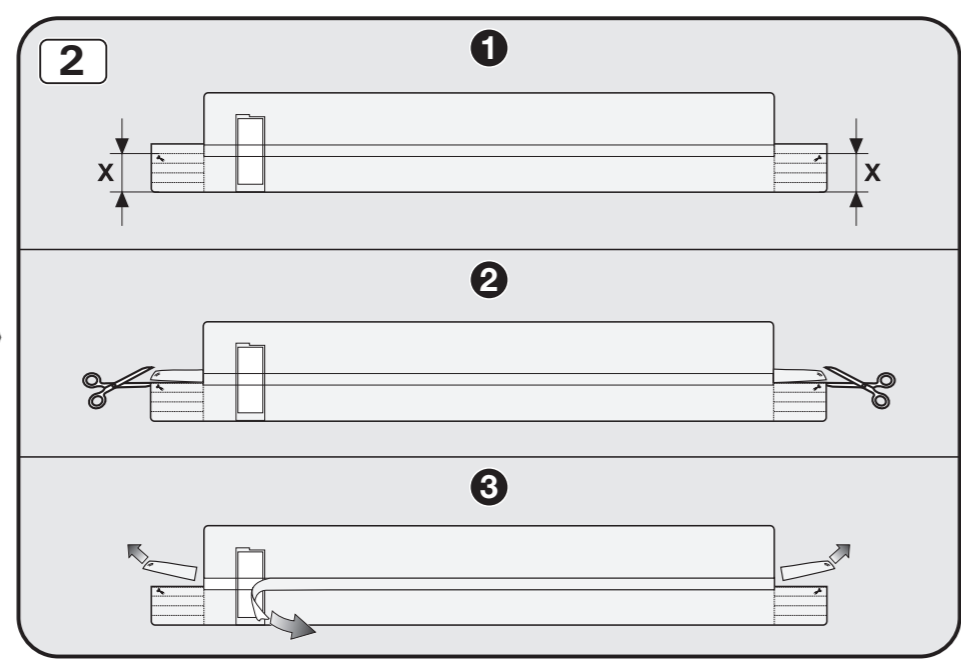
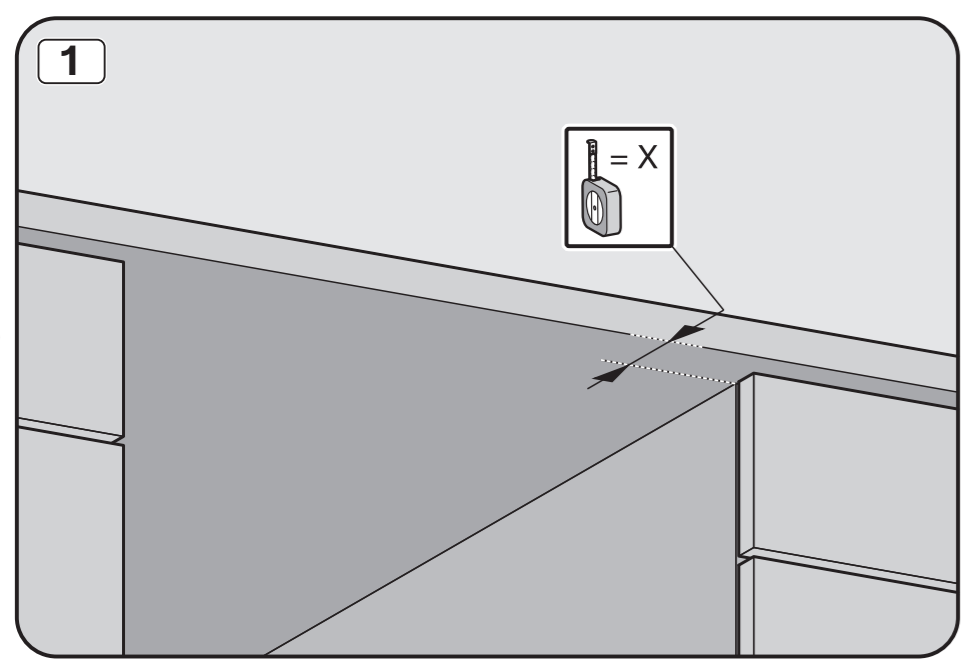

	(mm)	min.	max.
x		590	597
y		16	—
z		16	—