







## Operating and installation instructions Refrigerators



To avoid the risk of accidents or damage to the appliance it is **essential** to read these instructions before it is installed and used for the first time.

# Contents

---

<b>Warning and Safety instructions</b> .....	4
<b>Caring for the environment</b> .....	12
<b>Saving energy</b> .....	13
<b>Guide to the appliance</b> .....	15
Control panel .....	15
Symbols .....	16
Optional accessories .....	18
<b>Switching on and off</b> .....	20
Before using for the first time .....	20
Cleaning the appliance .....	20
Operating the appliance .....	21
Switching on .....	21
Switching off .....	21
Switching off for longer periods of time .....	21
<b>The correct temperature</b> .....	22
... in the refrigerator section and in the PerfectFresh Pro zone .....	22
Automatic temperature distribution (DynaCool) .....	22
Temperature display .....	23
Setting the temperature .....	23
Adjusting the temperature in the PerfectFresh Pro zone .....	24
<b>Using Super cool</b> .....	25
<b>Door alarm</b> .....	26
Switching the door alarm off early .....	26
<b>Selecting further settings</b> .....	27
Safety lock  .....	27
Audible signals  .....	28
Display brightness  .....	29
Sabbath mode  .....	30
Filter replacement indicator  .....	32
<b>Storing food in the refrigerator section</b> .....	33
Different storage zones .....	33
Food which is not suitable for storage in the refrigerator section .....	34
Notes on buying food .....	34
Storing food correctly .....	34
<b>Storing food in the PerfectFresh Pro zone</b> .....	35
Dry compartment  .....	36

---

Humidity-controlled compartment $\Delta$ , $\Delta\Delta$ / $\Delta\Delta\Delta$ .....	36
<b>Adjusting the interior fittings</b> .....	39
Adjusting the door shelf/bottle shelf .....	39
Adjusting the bottle holder .....	39
Moving the adjustable shelf/adjustable shelf with lighting.....	39
Adjusting the bottle rack .....	40
PerfectFresh Pro zone compartments.....	40
Moving the charcoal filters .....	41
<b>Defrosting</b> .....	43
<b>Cleaning and care</b> .....	44
Cleaning agents.....	44
Preparing the refrigeration appliance for cleaning .....	45
Cleaning the interior and accessories .....	46
Cleaning the door seal .....	48
Cleaning the ventilation gaps .....	48
After cleaning .....	48
Replacing the charcoal filters.....	48
<b>Problem solving guide</b> .....	50
<b>Noises</b> .....	58
<b>Service</b> .....	59
Contact in case of malfunction .....	59
Warranty .....	59
<b>Information for dealers</b> .....	60
Demo mode ■.....	60
<b>Installation</b> .....	62
Installation .....	62
Side-by-side combinations .....	62
Location.....	63
Ventilation.....	63
Furniture door panel .....	65
Before installing the appliance .....	66
Building-in dimensions .....	68
Limiting the opening angle of the appliance door.....	69
Changing the door hinging.....	69
Installing the appliance.....	73
Fitting the furniture door.....	81
Electrical connection .....	87

## Warning and Safety instructions

---

This refrigeration appliance complies with current safety requirements. Inappropriate use can, however, lead to personal injury and material damage.

Please read the operating and installation instructions carefully before using the refrigeration appliance for the first time. They contain important information on safety, installation, use and maintenance. This is to protect yourself from injury, and from damaging your refrigeration appliance.

In accordance with standard IEC 60335-1, Miele expressly and strongly advises that you read and follow the instructions in the chapter on installing the appliance as well as the safety instructions and warnings.

Miele cannot be held liable for injury or damage caused by non-compliance with these instructions.

Keep these instructions in a safe place and pass them on to any future owner.

### Correct application

- ▶ This refrigeration appliance is intended for use in the home and in similar environments, for example
  - in shops, offices and similar work settings
  - by the guests in hotels, motels, bed & breakfasts and other typical home settings.

This refrigeration appliance is not intended for outdoor use.

- ▶ This appliance is intended for domestic use only for cooling and storing food and drink.

It must not be used for any other purpose.

## Warning and Safety instructions

---

▶ This appliance is not suitable for storing and keeping cool medicines, blood plasma, laboratory preparations or other such materials or products. Incorrect use of the appliance for such purposes can cause deterioration of the items stored. The appliance is not suitable for use in areas where there is a risk of explosion.

Miele cannot be held liable for damage resulting from improper or incorrect use of the appliance.

▶ The appliance can only be used by people with reduced physical, sensory or mental capabilities, or lack of experience and knowledge, if they are supervised whilst using it, or have been shown how to use it in a safe way and recognise and understand the consequences of incorrect operation.

### **Safety with children**

▶ Children under 8 years of age must be kept away from the refrigeration appliance unless they are constantly supervised.

▶ Children 8 years and older may only use the appliance unsupervised if they have been shown how to use it in a safe way and recognise and understand the consequences of incorrect operation.

▶ Children must not be allowed to clean or maintain the appliance unsupervised.

▶ Please supervise children in the vicinity of the appliance and do not let them play with it.

▶ Danger of suffocation! Whilst playing, children could become entangled in packaging (such as plastic wrapping) or pull it over their head and suffocate. Keep packaging material away from children.

# Warning and Safety instructions

---

## Technical safety

► The coolant system is tested for leaks. This appliance complies with statutory safety requirements and the appropriate EU guidelines.



► This refrigeration appliance contains the coolant Isobutane (R600a), a natural gas which is environmentally friendly. The coolant does not damage the ozone layer and does not contribute to the greenhouse effect.

The use of this coolant has, however, led to a slight increase in the noise level of the appliance. In addition to the noise of the compressor, you might be able to hear the coolant flowing around the cooling circuit. Unfortunately, this cannot be avoided, but it does not affect the performance of the refrigeration appliance.

When transporting and installing the refrigeration appliance, ensure that no parts of the cooling circuit are damaged. Splashes of coolant can damage the eyes.

In the event of damage:

- Avoid naked flames or anything which creates a spark.
- Disconnect the refrigeration appliance from the mains electricity supply.
- Ventilate the room where the refrigeration appliance is located for several minutes.
- Contact the Miele Customer Service Department.

► The more coolant there is in a refrigeration appliance, the larger the room it should be installed in. In the event of a leakage, if the appliance is in a small room, there is the danger of combustible gases building up. For every 11 g of coolant at least 1 m<sup>3</sup> of room space is required. The amount of coolant in the appliance is stated on the data plate inside the appliance.

## Warning and Safety instructions

---

- ▶ To avoid the risk of damage to the appliance, make sure that the connection data (fuse rating, frequency and voltage) on the data plate corresponds to the household supply. Check that this is the case before connecting the appliance. Consult a qualified electrician if in any doubt.
- ▶ The electrical safety of this appliance can only be guaranteed when correctly earthed. It is essential that this standard safety requirement is met. If in any doubt please have the electrical installation tested by a qualified electrician.
- ▶ Reliable and safe operation of this appliance can only be assured if it has been connected to the mains electricity supply.
- ▶ If the electrical connection cable is faulty it must only be replaced by a Miele authorised service technician to protect the user from danger.
- ▶ Do not connect the appliance to the mains electrical supply by a multi-socket adapter or extension lead. These are a fire hazard and do not guarantee the required safety of the appliance.
- ▶ If moisture gets into electrical components or into the mains connection cable, it could cause a short circuit. Therefore, do not operate this refrigeration appliance in areas which are exposed to moisture (e.g in a garage or utility room).
- ▶ This appliance must not be used in a non-stationary location (e.g. on a ship).
- ▶ Do not use a damaged appliance. It could be dangerous. Check the appliance for visible signs of damage.
- ▶ For safety reasons, this appliance may only be used after it has been built in.
- ▶ The appliance must be isolated from the electricity supply during installation, maintenance and repair work.

## Warning and Safety instructions

---

- ▶ Unauthorised installation, maintenance and repairs can cause considerable danger for the user. Installation, maintenance and repairs must only be carried out by a Miele authorised technician.
- ▶ While the appliance is under warranty, repairs should only be undertaken by a Miele authorised service technician. Otherwise the warranty is invalidated.
- ▶ Miele can only guarantee the safety of the appliance when genuine original Miele replacement parts are used. Faulty components must only be replaced by Miele spare parts.



### Correct use

- ▶ The appliance is designed for use within a certain climate range (ambient temperatures), and should not be used outside this range. The climate range for your appliance is stated on the data plate inside the appliance. Installing it in a room with too low an ambient temperature, e.g. a garage, will lead to the appliance switching off for longer periods so that it cannot maintain the required temperature.
- ▶ Do not cover or block the air vents as this could impair the efficiency of the appliance, increase the electricity consumption and could cause damage to the components.
- ▶ If storing food which contains a lot of fat or oil in the appliance or the door, make sure that it does not come into contact with plastic components as this could cause stress cracks or break the plastic.
- ▶ Risk of fire and explosion. Do not store explosive materials in the refrigeration appliance or any products containing propellants (e.g. spray cans). Electrical components can cause flammable mixes of gases to ignite.
- ▶ Danger of explosion. Do not operate any electrical equipment (e.g. an electric ice-cream maker) inside the refrigeration appliance. Danger of sparking and explosion.
- ▶ Observe the manufacturer's "use-by" dates and storage instructions given on food to avoid the risk of food poisoning. Storage times will depend on several factors, including the freshness and quality of the food, as well as the temperature at which it is stored.
- ▶ Only use genuine original Miele accessories and spare parts with this appliance. Using accessories or spare parts from other manufacturers will invalidate the warranty, and Miele cannot accept liability.

# Warning and Safety instructions

---

## Cleaning and care

- ▶ Do not use any oils or grease on the door seals, as these will cause the seals to deteriorate and become porous with time.
- ▶ Do not use a steam cleaning appliance to clean or defrost this appliance.  
Steam could reach electrical components and cause a short circuit.
- ▶ Sharp edged or pointed objects will damage the evaporator, causing irreversible damage to the appliance. Do not use sharp edged or pointed objects to
  - remove frost and ice,
  - separate frozen foods or remove ice trays.
- ▶ Do not place electric heaters or candles in the appliance to defrost it. These can damage the plastic parts.
- ▶ Do not use defrosting sprays or de-icers, as they could contain substances which could damage the plastic parts or which might cause the build-up of gases and pose a danger to health.

## Transport

- ▶ Always transport the appliance in an upright position and in its original transport packaging to avoid damage in transit.
- ▶ Danger of injury and damage to the appliance. The refrigeration appliance is very heavy and must be transported by two people.

## Disposal of your old appliance

- ▶ If your old refrigeration appliance has a door lock, destroy it. This will prevent the risk of children playing accidentally locking themselves in and endangering their lives.
- ▶ Splashes of coolant can damage the eyes. Be careful not to damage any part of the pipework whilst awaiting disposal, e.g. by
  - puncturing the coolant channels in the condenser,
  - bending any pipework, or
  - scratching the surface coating.

## Symbol on the compressor (depending on model)

This information is only relevant for recycling. There is no risk during normal operation.



- ▶ The oil in the compressor can be fatal if swallowed or if it penetrates the airways.

# Caring for the environment

---

## Disposal of the packing material

The packaging is designed to protect the appliance from damage during transportation. The packaging materials used are selected from materials which are environmentally friendly for disposal and should be recycled.

Recycling the packaging reduces the use of raw materials in the manufacturing process and also reduces the amount of waste in landfill sites.

## Disposing of your old appliance

Electronic and electrical appliances contain many valuable materials. They also contain certain materials, compounds and components which were essential for their correct functioning and safety. These could be hazardous to your health and to the environment if disposed of with general waste or if handled incorrectly. Please do not, therefore, dispose of your old appliance with general waste.

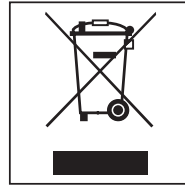

Instead, please make use of officially designated collection and disposal points to dispose of and recycle electrical and electronic appliances in your local community, with your dealer or with Miele. By law, you are solely responsible for deleting any personal data from the appliance prior to disposal.

Take care not to damage your refrigeration appliance's pipework before or during transportation to an authorised collection depot.

This is to ensure that coolant in the cooling circuit and oil in the compressor is contained, and will not leak into the environment.

Please ensure that your old appliance poses no risk to children while being stored prior to disposal. For further information, see "Warning and Safety instructions" in these operating and installation instructions.

## Saving energy

	<b>Normal energy consumption</b>	<b>Increased energy consumption</b>
<b>Installation / Maintenance</b>	In a ventilated room.	In an enclosed, unventilated room.
	Protected from direct sunlight.	In direct sunlight.
	Not near to a heat source (radiator, oven).	Near to a heat source (radiator, oven).
	Where the ideal ambient room temperature is approx. 20 °C.	Where the ambient room temperature is above 25 °C.
	Ventilation gaps uncovered and dusted regularly.	Ventilation gaps covered or dusty.
<b>Temperature setting</b>	Refrigerator section 4 to 5 °C	The lower the temperature, the higher the energy consumption.
	PerfectFresh Pro zone just above 0 °C	

# Saving energy

	<b>Normal energy consumption</b>	<b>Increased energy consumption</b>
<b>Use</b>	Drawers and shelves arranged as they were when the appliance was delivered.	
	Only open the door when necessary and for as short a time as possible. Store food in an organised way.	Frequent opening of doors for long periods will cause a loss of coldness. The appliance will try to cool down and the compressor will run for longer periods.
	Take an insulated cool bag when shopping, and load food in the appliance as soon as possible. Replace any food removed as quickly as possible, before it warms up too much. Allow hot food and drinks to cool down before placing them in the appliance.	Hot food or food at room temperature raises the temperature inside the appliance. The appliance will try to cool down and the compressor will run for longer periods.
	Store food well packaged or covered.	The evaporation or condensation of liquids in the refrigerator section will cause a loss of coldness.
	Place frozen food in the refrigerator to defrost.	
	Do not over-fill the appliance to allow air to circulate.	Poor air circulation will cause a loss of coldness.

## Control panel

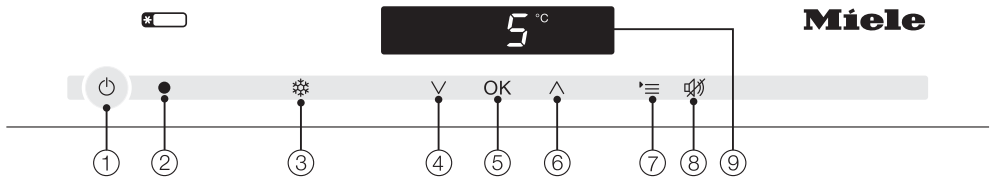









- ① On/Off sensor for the whole appliance
- ② Optical interface (for Service technicians only)
- ③ On/Off sensor for the Super cool function
- ④ For setting the temperature (∨ = colder)  
Selector sensor in settings mode
- ⑤ OK sensor for confirming a selection
- ⑥ For setting the temperature (^ = warmer)  
Selector sensor in settings mode
- ⑦ Sensor for accessing or leaving settings mode
- ⑧ For switching off the door alarm
- ⑨ Display with temperature and symbols (symbols only visible in settings mode, in the event of an alarm/message; see table for explanation of symbols)

# Guide to the appliance

---

## Symbols

Symbol	Meaning	Function
	Safety lock	Prevents the appliance being switched off, the temperature being altered, Super cool being switched on and settings being altered by mistake.
	Audible tones	Choice of sensor tone and door alarm tone
	Miele@home	Only visible when a communication module or communication stick is fitted and signed on
	Display brightness settings	For adjusting the brightness of the display
	Charcoal filter replacement indicator (Active AirClean)	This function must be activated after fitting a charcoal filter; it lights up to remind you to replace it
	Sabbath mode	For switching Sabbath mode on and off
	Mains connection	Confirms that the appliance is connected to the electricity supply when it is not switched on
	Alarm	Lights up when the door alarm is activated; flashes in the event of fault messages
	Demo mode (only visible when Demo mode is switched on)	For switching off Demo mode



# Guide to the appliance

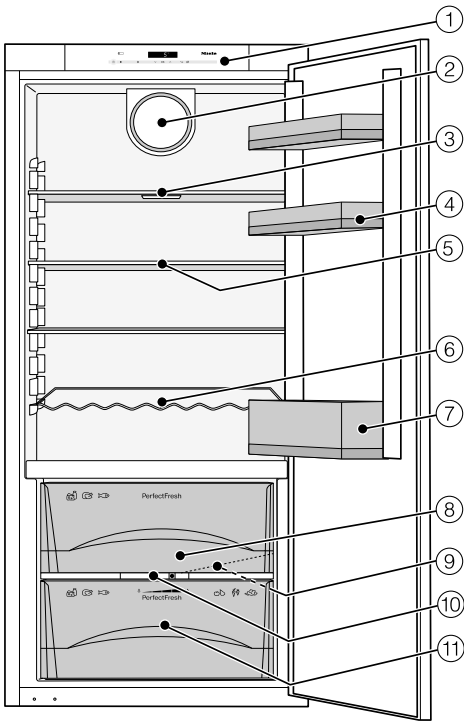

- ① Control panel
- ② Fan
- ③ Adjustable shelf with lighting (FlexiLight)
- ④ Door shelf / Egg tray
- ⑤ Adjustable shelf
- ⑥ Bottle rack
- ⑦ Bottle shelf
- ⑧ PerfectFresh Pro zone, dry compartment
- ⑨ Condensate channel and drain hole
- ⑩ Regulator for setting the moisture level in the humidity controlled compartments
- ⑪ PerfectFresh Pro humidity controlled zone (depending on model)

This drawing is for illustration purposes only.

The PerfectFresh Pro zone satisfies the requirements of a chill compartment to EN ISO 15502.

# Guide to the appliance

## Optional accessories

A range of useful Miele accessories and care products are available for your appliance.

Accessories are available to order via the Miele Webshop, from Miele directly (see back cover for contact details) or from your Miele dealer.

### Multi-purpose microfibre cloth

The microfibre cloth is suitable for removing fingerprints and light soiling from surfaces such as stainless steel, glass, plastic and chrome without the use of chemicals.

### MicroCloth Kit

The MicroCloth Kit contains a universal cloth, a glass cloth and a polishing cloth.

These cloths are extremely rip-proof and hard-wearing. Thanks to very fine microfibres these cloths achieve excellent cleaning results.

### Bottle rack

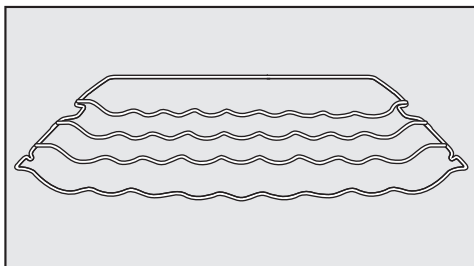

Bottles can be stored horizontally using the bottle rack to save space.

The bottle rack can be placed at different positions in the appliance.

## KKF-FF Active AirClean charcoal filters with holder

Charcoal filters neutralise unpleasant odours in the refrigerator section for improved air quality.

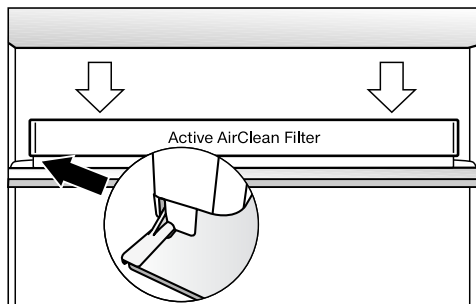

The charcoal filter holder clips onto the protective strip at the back of the shelf and can be moved as necessary.

Now activate the filter reminder in settings mode (see “Selecting further settings” - Filter replacement indicator 🌐).)

## KKF-RF Active AirClean replacement filters

Replacement filters to fit the Active AirClean holder are available. We recommend replacing the charcoal filters every 6 months.

### **XKS 3130 W WiFi stick (Miele@home)**

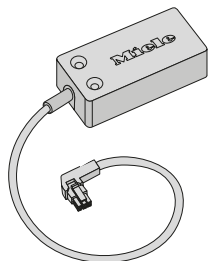

The WiFi stick enables your refrigeration appliance to communicate, so that you can access appliance data at any time with a smartphone or tablet (iOS® or Android™ operating systems).

To use the Miele@mobile app or Miele@home features, such as the option to switch on SuperCool/SuperFreeze, you must insert the WiFi stick into your Miele refrigeration appliance and connect it to your WiFi network.

Fitting and installation instructions for the stick are supplied with it and describe how to install the WiFi stick and connect to a WiFi network.

# Switching on and off

---

## Before using for the first time

### Packaging material

- Remove all packaging material from the inside of the appliance.

### Protective foil

The stainless-steel trim on the interior shelves and door shelves in the appliance has a layer of protective foil to prevent scratching in transit.

- Remove this protective foil once the appliance has been installed.

### Cleaning the appliance

Please refer to the relevant instructions in “Cleaning and care”.

- Clean the inside of the appliance and the accessories.

## Accessories

### Fitting the bottle holder

The non-slip fins of the bottle holder jut out into the bottle shelf and make bottles more secure when you open and close the appliance door.

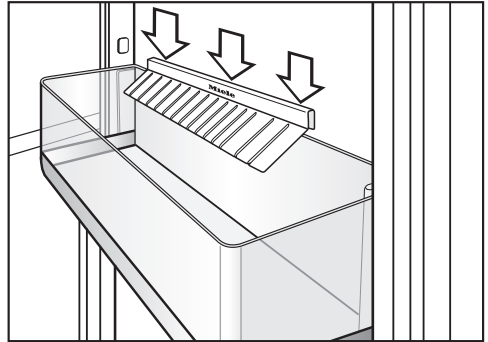

- Attach the bottle holder centrally along the rear edge of the bottle shelf.

## Operating the appliance

A light touch of the finger on the sensors is all that is required to operate this appliance.

A tone will sound each time a sensor is touched. You can deactivate this, if you wish (see “Selecting further settings - Audible tones”).

## Switching on

When the appliance is connected to the electrical supply, the mains connection symbol  will appear in the display after a short while.



- Touch the On/Off sensor.

The mains connection symbol  will go out and the temperature display will appear.

The appliance will start cooling.

When the door is opened, the interior lighting comes on and the LED lighting on the adjustable shelves becomes brighter until it reaches its maximum brightness.

To enable the temperature to get sufficiently cold inside the appliance, allow the appliance to run for a few hours before placing food in it.

## Switching off



- Touch the On/Off control.  
If this does not work, the safety lock is activated.

The temperature display will go out and the mains connection symbol  will appear.

The interior lighting goes out and cooling is turned off.

## Switching off for longer periods of time

If, during a long absence, the refrigeration appliance is switched off but not cleaned and the door(s) left shut, there is a risk of mould forming inside the appliance.

It is essential to clean the refrigeration appliance.

If the refrigeration appliance is not going to be used for a longer period of time, observe the following:

- Switch the refrigeration appliance off.
- Switch off at the wall socket and withdraw the plug from the socket, or disconnect the fuse.
- Clean the refrigeration appliance and leave the door ajar to air the appliance and avoid odours building up inside.

# The correct temperature

---

It is very important to set the correct temperature for storing food in the appliance. Bacteria will cause food which is not stored at the correct temperature to deteriorate rapidly. Temperature influences the growth rate of these bacteria. Reducing the temperature reduces their growth rate.

The temperature in the refrigeration appliance will rise:

- The more often the appliance door is opened and the longer it is kept open
- The more food that is stored in it
- The warmer the food is which is being put into it
- The higher the ambient temperature surrounding the refrigeration appliance. This refrigeration appliance is designed for use within specific ambient temperatures (climate range). Do not use in ambient temperatures for which it is not designed.

## **... in the refrigerator section and in the PerfectFresh Pro zone**

We recommend a temperature of **4 °C** in the refrigerator section.

The temperature in the PerfectFresh Pro zone is controlled automatically and maintained at **0 to 3 °C**.

## **Automatic temperature distribution (DynaCool)**

The fan switches on automatically when the cooling system for the refrigerator switches on. It distributes the temperature in the appliance to all areas more evenly so that all the food will be chilled to about the same degree.

## Temperature display

In normal operation the temperature display shows the **average, current temperature in the refrigerator**.

Depending on the ambient temperature and the temperature setting, it can take the appliance a few hours to reach the temperature required and for this temperature to then be shown as a constant temperature in the display.

## Setting the temperature

- Use the two sensors underneath the display to set the temperature.

By touching the sensor



- the temperature will get colder,



- the temperature will get warmer.

The temperature being set will flash in the display.

The following information shows in the display while the sensors are being touched:

- Touching a sensor once: the **last temperature selected** flashes.
- Each subsequent touch of the sensor: adjusts the temperature shown in 1°C steps.

- Leaving a finger on the sensor changes the temperature continuously.

Approximately 5 seconds after the last time a sensor has been touched, the **current** temperature inside the appliance is automatically shown.

### Or

- Touch the OK sensor to confirm your selection.

If you have adjusted the temperature, **wait for approx. 6 hours if the appliance is not very full and for approx. 24 hours if the appliance is full** before checking the temperature display, as it will take this long for the appliance to give an accurate reading.

- If, after this time, the temperature is still too high or too low, you will need to adjust it again.

## Temperature range

The temperature can be adjusted from 3 °C to 9 °C.

# The correct temperature

## Adjusting the temperature in the PerfectFresh Pro zone

In the PerfectFresh Pro zone, the temperature is automatically maintained between 0 and 3 °C. However, if you would like it to be warmer or colder, e.g. when storing fish, you can adjust the temperature slightly.

The standard setting for the temperature in the PerfectFresh Pro zone is 5. Under certain circumstances, a setting from 1 to 4 can cause negative temperatures to be reached. Food could freeze. Select a higher level.



- Touch the settings button.

All symbols available for selection will appear in the display and the  symbol flashes.



- Touch the buttons for setting the temperature (^ or v) repeatedly until the  symbol flashes.



- Touch the OK button to confirm your selection.

The last selected setting flashes and the  symbol lights up in the display.



- You can now adjust the temperature in the PerfectFresh Pro zone by touching the v or ^ button. You can choose from settings 1 to 9: 1: lowest temperature, 9: highest temperature.



- Touch the OK button to confirm your selection.

The selected setting is applied, the  symbol flashes.



- Touch the settings button to leave settings mode. Otherwise, the appliance electronics will exit the settings mode automatically after approximately one minute.

The newly set temperature for the PerfectFresh Pro zone will be reached gradually.



## Super cool function

The Super cool function can be used to rapidly reduce the temperature in the refrigerator to its lowest setting (depending on the room temperature).

### Switching on Super cool

Super cool is particularly recommended for the rapid chilling of large amounts of fresh food or drink.



- Touch the Super cool sensor so that it is highlighted in yellow.

The appliance will work at full power to lower the temperature in the refrigerator section.

### Switching off Super cool

The Super cool function switches off automatically after approx. 12 hours. The appliance will then continue to work at normal power.

To save energy, the Super cool function can be switched off once food and drinks are sufficiently chilled.



- Touch the Super cool sensor so that it is no longer highlighted in yellow.

The appliance will continue running at normal power.

## Door alarm

---

The appliance is fitted with a warning system to avoid increased energy consumption and food becoming warm if the door is left open.

The alarm will sound if the door is left open for a long time. The alarm symbol  lights up in the display.

The amount of time until the door alarm is triggered depends on the setting selected and can be either 2 minutes (factory default) or 4 minutes. However, the door alarm can also be turned off (see “Selecting further settings” – “Audible signals”).

As soon as the door is closed, the alarm stops sounding and the alarm symbol  disappears from the display.

If the audible signal does not sound in the event of a door alarm, then the audible signal has been switched off in settings mode (see “Selecting further settings” – “Audible signals”).

### Switching the door alarm off early

If the noise disturbs you, you can switch the alarm off if you wish.



- Touch the sensor for switching off the door alarm.







The alarm sound will stop.  
The alarm symbol  will continue to be lit up until the door is closed.

# Selecting further settings

Certain settings on the appliance can only be selected in settings mode.

When in settings mode, the door alarm and other fault messages are automatically deactivated although the alarm symbol  appears in the display.

## Available settings

	Activating or deactivating the safety lock
	Switching audible tones on/off
	Altering the display brightness
	Adjusting the temperature in the PerfectFresh Pro zone
	Switching Sabbath mode on/off
	Activating the filter replacement indicator or resetting the counter

**Adjusting the temperature in the PerfectFresh Pro zone** is described in “The correct temperature”.

The other further settings are described in more detail below.

## Safety lock

The safety lock can be activated to prevent:

- the appliance being switched off by mistake,
- the temperature being changed by mistake,
- Automatic SuperCool being selected by mistake,
- settings being adjusted by mistake (it is only possible to deactivate the safety lock).

This prevents the appliance being switched off or settings being adjusted without your knowledge (by children, for example).

## Activating or deactivating the safety lock



- Touch the settings sensor.

All symbols available for selection will appear in the display and the  symbol flashes.



- Touch the OK sensor to confirm your selection.

The last selected setting flashes and the  symbol lights up in the display.

## Selecting further settings

---



- By touching the  $\wedge$  or  $\vee$  sensor, you can now select whether the safety lock is activated or deactivated:  
 $\nabla$ : the safety lock is deactivated  
 $\blacktriangledup$ : the safety lock is activated



- Touch the OK sensor to confirm your selection.

The selected setting is applied, the  symbol flashes.



- Touch the settings sensor to leave settings mode. Otherwise the appliance exits settings mode automatically after approximately one minute.

The  symbol will appear in the display when the lock is activated.

## Audible signals

The appliance features audible signals such as a keypad tone and door alarm tone.

The keypad tone and door alarm tone can be switched on or off.

There are 4 settings to choose from. Option 3 is set at the factory; this means that the keypad tone and the door alarm are switched on.

## Switching audible signals on/off



- Touch the settings sensor.

All symbols available for selection appear in the display and the  symbol flashes.



- Touch the sensors for setting the temperature ( $\wedge$  or  $\vee$ ) repeatedly until the  symbol flashes.



- Touch the OK sensor to confirm the selection.

The most recently selected setting flashes and the  symbol lights up in the display.

## Selecting further settings



- Touch the  $\wedge$  or  $\vee$  sensor now to select:

$\bar{0}$ : keypad tone off; door alarm off

$1$ : keypad tone off; door alarm on (after 4 minutes)

$2$ : keypad tone off; door alarm on (after 2 minutes)

$3$ : keypad tone on; door alarm on (after 2 minutes).



- Touch the OK sensor to confirm the selection.

The selected setting is applied, the  $\text{♪}$  symbol flashes.



- Touch the settings sensor to exit settings mode. Otherwise, the appliance electronics will exit the settings mode automatically after approximately one minute.

### Display brightness $\text{☀}$

The display brightness can be adjusted to suit lighting conditions in the room.

The display brightness can be adjusted in steps from  $1$  to  $3$ . The factory default setting is  $3$  (maximum brightness).

### Altering the display brightness



- Touch the settings sensor.

All symbols available for selection will appear in the display and the  $\text{🔒}$  symbol flashes.



- Touch the sensors for setting the temperature ( $\wedge$  or  $\vee$ ) repeatedly until the  $\text{☀}$  symbol flashes.



- Touch the OK sensor to confirm your selection.

The last selected setting flashes and the  $\text{☀}$  symbol lights up in the display.

# Selecting further settings



- By touching the  $\wedge$  or  $\vee$  sensor you can now alter the brightness of the display:  
1: dimmest setting  
2: medium setting  
3: brightest setting.



- Touch the OK sensor to confirm your selection.

The selected setting is applied, the  symbol flashes.



- Touch the settings sensor to leave settings mode. Otherwise the appliance exits settings mode automatically after approximately one minute.

## Sabbath mode

The appliance has a Sabbath mode to support the observance of religious customs.

The following are switched off:

- the interior lighting when the door is opened,
- all acoustic and visual signals,
- the temperature display,
- Super cool (if previously switched on).

The following can be selected:

- the settings button  for switching off Sabbath mode
- and the On/Off button.

The Sabbath mode function will switch itself off automatically after approx. 120 h.

Ensure that the door is properly closed, as visual and audible alarms are switched off.

 **Danger of food contamination!**  
Any power failure during Sabbath mode is not shown in the display. After a power failure, the appliance restarts in Sabbath mode. When power is restored, no notification of the power failure will appear in the display.

If there was a power failure during Sabbath mode, check the quality of the food and do not consume partially thawed food.

## Selecting further settings

### Switching on Sabbath mode



- Touch the settings sensor.

All symbols available for selection will appear in the display and the  symbol flashes.



- Touch the sensors for setting the temperatures ( $\wedge$  or  $\vee$ ) repeatedly until the  symbol flashes.



- Touch the OK sensor to confirm your selection.

The last selected setting flashes and the  symbol lights up in the display.



- By touching the  $\wedge$  or  $\vee$  sensor you can now switch on Sabbath mode. To do this, select setting 1



- Touch the OK sensor to confirm your selection.

The selected setting is applied, the  symbol lights up.

As soon as the  symbol goes out in the display after 3 seconds, Sabbath mode is switched on.

- Switch off Sabbath mode after the Sabbath has passed.

### Switching off Sabbath mode



- Touch the settings sensor to leave Sabbath mode.

The temperature will appear in the display and the interior lighting will come on.

## Selecting further settings

### Filter replacement indicator

The appliance is not supplied with filters with holder KKF-FF (Active AirClean). These are available to purchase separately (see “Optional accessories”).

After fitting filters, the filter replacement indicator has to be activated.

You will be reminded to replace the filters after approx. 6 months (see “Cleaning and Care - Replacing the charcoal filters”). The  symbol will light up in the display.

After replacing the filter(s), the counter must be reset. The indicator will then go out.

### Activating the filter replacement indicator or resetting the counter



- Touch the settings button.

All symbols available for selection will appear in the display and the  symbol flashes.



- Press the buttons for setting the temperature (^ or v) as often as necessary until the  symbol flashes.



- Press the OK button to confirm the selection.

The most recently selected setting flashes and the  symbol lights up in the display.



- Touch ^ or v to make your selection  
∅: Replacement indicator deactivated  
?: Replacement indicator activated  
z: Counter reset.



- Press the OK button to confirm the selection.

The selected setting is applied, the  symbol flashes.



- Touch the settings button to leave settings mode.  
Otherwise, the appliance electronics will exit the settings mode automatically after approximately one minute.



# Storing food in the refrigerator section

 Risk of explosion due to flammable mixes of gases.

Electrical components can cause flammable mixes of gases to ignite.

Do not store explosive materials in the refrigeration appliance or any products containing propellants (e.g. spray cans).

 Risk of damage due to greasy or oily foods.

If storing food which contains a lot of fat or oil in the refrigeration appliance or the appliance door, make sure that it does not come into contact with plastic components as this could cause stress cracks or break the plastic.

Make sure that no fat or oil leaks onto the plastic parts of the refrigeration appliance.

**Tip:** Do not store food in such a way that it touches the rear wall of the refrigerator section as it may freeze to the rear wall.

This appliance has automatic Dynamic cooling, which helps to keep an even temperature when the fan is running, making the difference between the various zones is less pronounced.

## Warmest area

The warmest area in the refrigerator section is at the top in the front area and in the door. Use this for storing butter and cheese.

## Coldest area

The coldest area in the refrigerator section is directly above the PerfectFresh Pro zone dividing plate and at the back of the appliance. The temperature in the PerfectFresh Pro zone compartments is even colder.

Use these areas in the refrigerator and in the PerfectFresh Pro zone for all delicate and highly perishable food, e.g.

- fish, meat, poultry,
- sausage products, ready meals,
- dishes or baked goods containing eggs or cream,
- fresh dough, cake mixtures, pizza or quiche dough,
- soft cheese and other dairy products,
- pre-packed vegetables and other fresh food with a label stating it should be kept at a temperature of approx. 4 °C.

## Different storage zones

Due to natural air circulation, there are different temperature zones in the refrigerator section.

Cold, heavy air sinks to the lowest section of the refrigeration section. Make use of the different zones when placing food in the appliance.

**Tip:** To allow air to circulate efficiently, do not pack food too closely together in the appliance.

If there is insufficient air circulation, the cooling performance will decrease and energy consumption will increase.

Do not cover the fan in the rear wall of the appliance.

# Storing food in the refrigerator section

---

## Food which is not suitable for storage in the refrigerator section

Not all food is suitable for refrigeration at temperatures below 5 °C, because it may be sensitive to cold. Depending on the type of food, the appearance, consistency, flavour and/or vitamin content may be altered if stored at too cold a temperature.

Foods which are sensitive to cold include:

- Pineapples, avocados, bananas, pomegranates, mangoes, melons, papayas, passionfruit, citrus fruits such as lemons, oranges, mandarins, grapefruits
- Fruit (which is not yet ripe)
- Aubergines, cucumbers, potatoes, peppers, tomatoes, courgettes
- Hard cheeses (e.g. Parmesan, mountain cheese)

## Notes on buying food

The freshness of food when first placed in the appliance is an important factor in determining how long it stays fresh, and how long it can be kept in the appliance.

Take into account the use-by date and the correct storage temperature.

Time out of the refrigerator, e.g. transporting food in a warm car, should be kept to a minimum.

**Tip:** Take an insulated cool bag when shopping, and load food in the appliance as soon as possible.

## Storing food correctly

Food should generally be stored covered or packaged in the refrigerator section (there are some exceptions to this rule in the PerfectFresh Pro zone - see below). This will prevent food smells from affecting other foods, food from drying out, and also any cross-contamination of bacteria. This is especially important for storing protein-based food such as meat or fish.

The growth of bacteria, such as salmonella, can be avoided by setting the correct temperature and maintaining good standards of hygiene.

# Storing food in the PerfectFresh Pro zone

The PerfectFresh Pro zone provides ideal storage conditions for fruit, vegetables, fish, meat and dairy products. Food stays fresh considerably longer while retaining both flavour and vitamins.

The temperature in the PerfectFresh Pro zone is maintained automatically at between 0 and 3 °C. While lower than the temperature in a standard refrigerator, this is the optimum temperature range for storing fresh food which is not sensitive to cold. The deterioration process is decelerated at this temperature range so food can be stored without loss of freshness for considerably longer than in a standard refrigerator.

The humidity level in the PerfectFresh Pro zone can also be regulated to suit the food being stored. Food retains its own moisture if stored at a higher humidity and so does not dry out as quickly. This allows it to stay crisp and fresh for longer.

Remember that the fresher the food when placed in the appliance, the longer it will stay fresh.

Take food out of the PerfectFresh Pro zone approx. 30 to 60 minutes before using it. The aroma and taste do not fully develop until the food has reached room temperature.

## The PerfectFresh Pro zone is divided into two areas:

The **Info system** (shown here in sections) above the PerfectFresh Pro zone helps you to choose the correct compartment and the appropriate setting in the humidity controlled compartment.



- The temperature is between 0 and 3 °C in the top **dry compartment** and the humidity level is not increased  $\Delta$ . Use this compartment to store fish, meat, dairy products and any other type of food, providing it is wrapped.

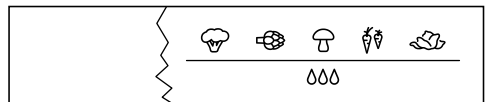
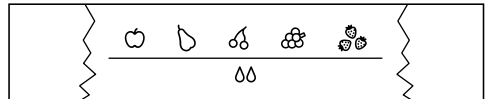

- The temperature is between 0 - 3 °C in the bottom **humidity controlled compartment** (depending on model, there may be one or more of this type of compartment). Depending on the position of the regulator, the humidity level is not increased  $\Delta$  or increased  $\Delta\Delta$  /  $\Delta\Delta\Delta$ . Fruit and vegetables can be stored in this compartment with the humidity increased.

Each type of food has its own characteristics which determine the specific storage conditions it requires.

# Storing food in the PerfectFresh Pro zone

---

## Dry compartment $\Delta$

The dry compartment is ideal for storing foods which perish easily, such as

- fish and seafood;
- meat, poultry and sausages;
- salads and lettuce;
- dairy products, e.g. yogurt, cheese, cream, quark etc;
- you can also use the dry compartment to store all kinds of food, providing it is wrapped.

The main advantage of the dry compartment is the low temperature (rather than the humidity). The humidity in the dry compartment is approximately the same as in a standard refrigerator.

Please note that food rich in protein deteriorates faster than other types of food.

Shellfish, for example, deteriorates faster than fish, and fish deteriorates faster than meat.

Always keep these foods **covered or wrapped**.

## Humidity-controlled compartment $\Delta, \Delta\Delta / \Delta\Delta\Delta$

### Humidity level not increased $\Delta$

At the  $\Delta$  setting the humidity controlled compartment becomes a dry compartment - the regulator opens the vents in the compartment to let the moisture escape (see “Dry compartment  $\Delta$ ”).

### Increased humidity $\Delta\Delta/\Delta\Delta\Delta$

With the regulator at the  $\Delta\Delta$  or  $\Delta\Delta\Delta$  setting, the humidity-controlled compartment is suitable for storing fruit and vegetables:

- Select the  $\Delta\Delta$  setting if storing a large quantity of fruit and vegetables (the regulator partially closes the vents in the compartment so that some of the moisture already present is retained).
- Select the  $\Delta\Delta\Delta$  setting if using the humidity-controlled compartment to store only a small quantity of fruit and vegetables (the regulator closes the vents in the compartment completely so that all of the moisture already present is retained).

**Tip:** If the humidity level is too high and a lot of moisture has collected in the compartment, select the  $\Delta\Delta$  setting. If the humidity level is too low, place the food in airtight packaging.

The humidity level greatly depends on the type and quantity of food being stored, if stored unwrapped.

# Storing food in the PerfectFresh Pro zone

High humidity in the humidity-controlled compartment can cause condensate to build up on the floor of the compartment as well as beneath the lid.

Wipe off any condensate with a cloth.

## Note for test institutes:

When measuring energy consumption in accordance with the standard, the regulator in the humidity-controlled compartment should be set to the  $\Delta$  setting (“humidity not increased”).

## Regulating the humidity level in the humidity-controlled compartment

A slide control is used to regulate the amount of moisture in the humidity controlled compartment by setting it to  $\Delta$ ,  $\Delta\Delta$  or  $\Delta\Delta\Delta$ .

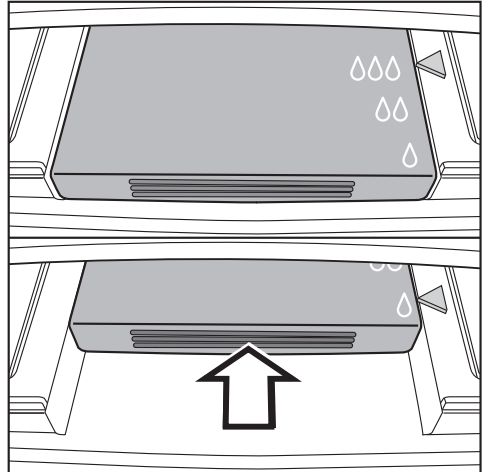

- Push the regulator back as far as it will go and then release it slowly.

The regulator will click into the  $\Delta$  setting automatically

- To select the  $\Delta\Delta$  or  $\Delta\Delta\Delta$  setting, push the regulator back and release it again to engage it in the  $\Delta\Delta$  or  $\Delta\Delta\Delta$  position.

# Storing food in the PerfectFresh Pro zone

---

**The following tips may help if you find that food you have stored does not keep well (e.g. food becomes limp or wilts after only being stored for a short time):**

- Only use the appliance for storing fresh food. The condition of the food when it is first placed in the appliance is an important factor in determining how long it stays fresh.
- Clean the PerfectFresh Pro compartments before storing food in them.
- Allow very moist food to drain before placing it in the PerfectFresh Pro zone
- Do not store food which is sensitive to cold in the PerfectFresh Pro zone (see “Food which is not suitable for storing in the refrigerator”).
- Select the correct PerfectFresh Pro compartment as well as the correct position for the humidity controlled compartment regulator (humidity not increased or humidity increased).
- Increased humidity ∆∆ / ∆∆∆ in the humidity controlled compartment is achieved via the moisture present in the food being stored, i.e. the more food stored in the compartment, the higher the humidity.  
If too much moisture has gathered on the floor of the compartment and the food has been affected, select the ∆∆ setting. Otherwise dry the floor and underneath the lid with a cloth and place a rack or similar item in the compartment so that moisture can then drip down.  
If the humidity level becomes too low at the ∆∆∆ setting, wrap the food in airtight packaging.
- If you think that the temperature in the PerfectFresh Pro zone is too high or too low, try regulating it by altering the temperature of the refrigerator section slightly by 1 to 2 °C. The temperature must be increased if ice crystals start to form on the floor of the PerfectFresh Pro zone as otherwise the cold temperature will damage the food.

# Adjusting the interior fittings

## Adjusting the door shelf/bottle shelf

**Tip:** Only move the appliance door shelves/bottle shelves when they are empty.

- Push the door shelf/bottle shelf upwards, then remove it by pulling it forwards.
- Replace the shelf at the required height. Ensure that it is securely pushed back into position.

## Adjusting the bottle holder

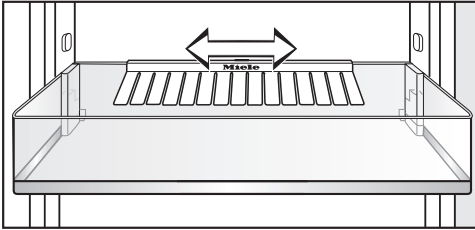

The bottle holder can be moved left or right to create more room for drink cartons.

The bottle holder can be removed completely (e.g. for cleaning):

- Push the bottle shelf upwards, then remove it by pulling it forwards
- Pull the bottle holder upwards to remove it from the rear edge of the bottle shelf.

## Moving the adjustable shelf/ adjustable shelf with lighting

By adjusting the position of the adjustable shelf with lighting in the refrigerator section, you can change the illumination in this section according to your needs.

Stoppers prevent the shelves from being dislodged by mistake.

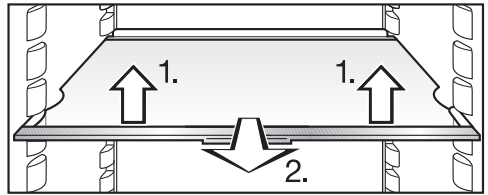

- The shelves can be adjusted according to the height of the refrigerated goods:

1. Lift it upwards slightly at the front.
2. Pull it forwards a little and lift it until the notch at the side is in line with the shelf support. It can then be raised or lowered to the required level.

- Push the shelf in until it clicks into position.

The raised edge on the protective strip at the back must face upwards to prevent food from touching the back of the appliance and freezing to it.

# Adjusting the interior fittings

## Adjusting the bottle rack

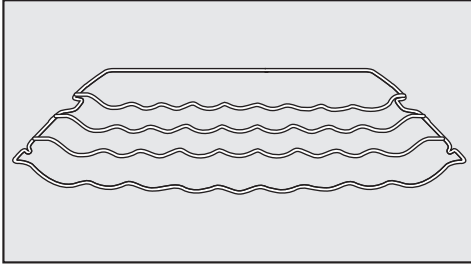

The bottle rack can be placed at different positions in the appliance.

- Raise the bottle rack slightly at the front, and pull it forwards a little until the notch at the side is in line with the shelf support. It can then be raised or lowered to the required level.

The rear rail must face upwards to prevent bottles from touching the back of the appliance.

Stoppers prevent the bottle rack from being dislodged by mistake.

## PerfectFresh Pro zone compartments

The compartments in the PerfectFresh Pro zone are on telescopic runners, and can be removed for filling, emptying or cleaning purposes.

Remove the bottle shelf from the door to make it easier to take out the compartments.

- Pull the drawer out as far as it will go.

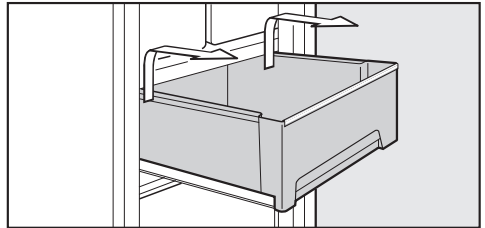

- Holding the sides of the compartment at the back, lift it up and then forwards and out.

Push the runners back in again to avoid damaging them.

- Carefully pull out the lid between the compartments slightly, and lift it down and out.



# Adjusting the interior fittings

Take care when cleaning the appliance that you do not wash the special lubricant out of the telescopic runners.

Wipe them with a well-wrung out damp cloth only.

- To replace the compartment lid, insert it from beneath into the holders, and push it back until it clicks into place.

## To replace the compartments

- Push the runners back in completely and then place the compartments on them.
- Push the compartments back into the appliance until they click into position.

## Moving the charcoal filters

Charcoal filters and a KKF-FF (Active AirClean) holder are available as optional accessories (see “Accessories - optional accessories”).

Replace the charcoal filters in the holder every 6 months.

Replacement KKF-RF charcoal filters can be obtained from Miele, from your dealer or from Miele's website.

**Tip:** The charcoal filter holder is dishwasher-proof.

- Pull the charcoal filter holder upwards to remove it from the shelf.

When in position, the charcoal filters must not touch the back wall of the appliance as the moisture could cause them to stick to the back wall. Insert the new charcoal filters into the holder so that they do not protrude over the edge of the holder.

## Adjusting the interior fittings

---

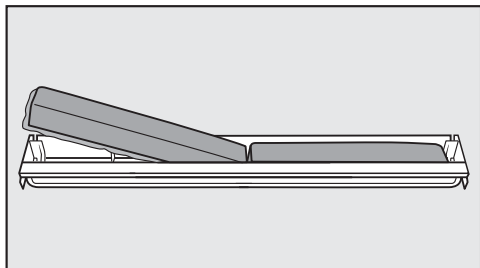

- Remove both charcoal filters and place the new filters with the framed edge pointing downwards in the holder.

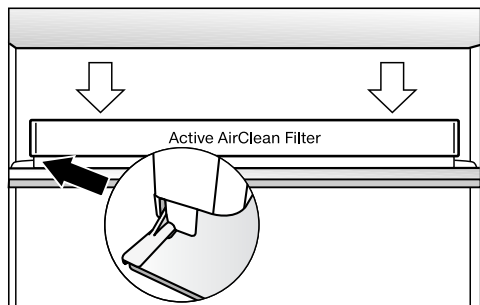

- Place the holder in the middle of the raised edge at the back of the shelf, so that it clicks into position.

## Refrigerator section and PerfectFresh Pro zone

The refrigerator section and the PerfectFresh Pro zone defrost automatically.

Condensate and frost can build up on the back wall of the refrigerator section and the PerfectFresh Pro zone while the compressor is running. You do not need to remove this, as it will defrost and evaporate automatically with the warmth generated by the compressor.

The condensate drains through a channel and drain pipe into an evaporation system at the back of the refrigeration appliance.

Keep the condensate channel and drain hole clean to enable this. Condensate must be able to drain away unhindered at all times.

# Cleaning and care

---

Do not let water get into the electronic module or the lighting.

 Risk of damage due to moisture ingress.

The steam from a steam cleaner can damage plastic and electrical components.

Do not use a steam cleaner to clean the refrigeration appliance.

Cleaning water must not get into the drain hole.

The data plate located inside the interior cabinet of the refrigeration appliance must not be removed. It contains information which is required in the event of a fault.

## Cleaning agents

To avoid damaging the surfaces of your appliance, **do not use**:

- Cleaning agents containing soda, ammonia, acids or chlorides
- Cleaning agents containing descaling agents
- Abrasive cleaning agents (e.g. scouring powder, scouring liquid or pumice stones)
- Cleaning agents containing solvents
- Stainless steel cleaning agents
- Dishwasher cleaner
- Oven sprays
- Glass cleaning agents
- Hard, abrasive sponges and brushes (e.g. pot scourers)
- Eraser stain remover blocks
- Sharp metal scrapers

Cleaning and conditioning agents used in the interior cabinet of the refrigeration appliance must be food safe.

We recommend using lukewarm water with a little washing-up liquid for cleaning.

## Preparing the refrigeration appliance for cleaning

- Switch the refrigeration appliance off.

The display goes out and the cooling function is switched off.

- Switch off at the wall and withdraw the plug from the socket, or disconnect the mains fuse.
- Take any food out of the refrigeration appliance and store it in a cool place.
- Remove the shelves and bottle shelf from the door.
- Remove the compartments and the compartment lid from the PerfectFresh Pro zone (see “Adjusting the interior fittings - PerfectFresh Pro zone compartments”).
- Take the glass plate out of the dividing plate.
- Take out all other removable parts for cleaning.

## Dismantling the adjustable shelf/adjustable shelf with lighting

⚠ Risk of damage as a result of incorrect cleaning.

The stainless steel trim with LED lighting will be damaged if you place it in water for cleaning.

Clean the stainless steel trim with LED lighting with a damp cloth.

Remove the stainless steel trims or stainless steel trim with LED lighting before cleaning the adjustable shelves in the dishwasher.

To remove the stainless steel trim and the rear protective strips, proceed as follows:

- Place the adjustable shelf on a soft surface (e.g. a tea towel) with the top side facing downward.

⚠ Risk of damage as a result of incorrect handling.

When you remove the stainless steel trim with LED lighting, the contacts (metal disc) can be damaged.

These contacts in the front left corner supply power to the LED lighting. Ensure that you always loosen the side on which the contacts are not located first.

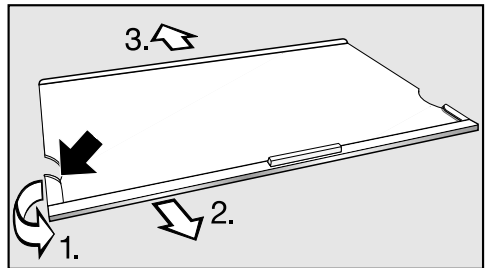

- Grasp the plastic surround on the left-hand side of the stainless steel trim at its rearmost point.
1. Pull the plastic surround from the adjustable shelf and
  2. pull the trim off at the same time. The opposite side will also be released.
  3. Then pull the protective strip off.
- After cleaning, reattach the stainless steel trim or protective strip by following the same procedure in reverse.

# Cleaning and care

## Bottle and door shelves

The stainless steel trim on the bottle and door shelves is **not** suitable for cleaning in a dishwasher.

To remove the stainless steel trim, proceed as follows:

- Place the shelf on a worktop, with the front face down.

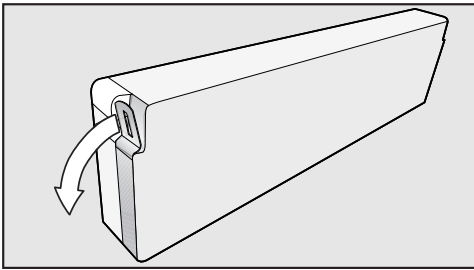

- Grasp one end of the trim and bend it away from the shelf. The complete trim will then detach from the shelf
- After cleaning, refit the stainless steel trim to the shelf in the reverse order

## Cleaning the interior and accessories

Clean the appliance at least once a month.

Remove soiling immediately to prevent it from drying on.

- Clean the interior with lukewarm water and a little washing-up liquid applied with a soft sponge. After cleaning, wipe with a clean, damp cloth and then dry with a soft cloth.

The stainless steel trim on the shelves, bottle or door shelves is **not suitable** for cleaning in a dishwasher.

Remove the stainless steel trim and strips before putting the shelves into the dishwasher.

The following parts **cannot be cleaned in a dishwasher**:

- the stainless steel trim or strips
- the protective strips at the back of the adjustable shelves
- all drawers and drawer lids (depending on model)
- the bottle rack
- These accessories should all be hand washed.

The following parts **can be cleaned in the dishwasher**:

The maximum temperature of the dishwasher programme selected must not exceed 55 °C.

Contact with natural dyes from carrots, tomatoes and ketchup, etc. may discolour the plastic parts in the dishwasher.

This discolouration does not affect the stability of the parts.

- bottle holder, butter dish, egg tray (depending on model)
- the bottle shelf and shelves in the door (with stainless steel trim removed)
- the adjustable shelves (with the trim and strips removed)
- the holder for the charcoal filter (optional accessory)

- Clean the condensate channel and drain hole frequently so that condensate can drain away unhindered. Use a straw or similar to clear the drain hole if necessary.

To do this, remove the PerfectFresh Pro zone drawers.

 Be careful not to wash out the special lubricant in the telescopic runners during cleaning.

- The PerfectFresh Pro zone drawers are on telescopic runners. Wipe the telescopic runners with a damp cloth to clean them.
- Miele stainless steel conditioning agent can be used to remove any soiling from the stainless steel trim.

**Tip:** It is important to treat the stainless steel trim with Miele stainless steel conditioning agent each time it is cleaned. This will protect the surface and help prevent re-soiling.

- Leave the door open to air the appliance for a short while and to prevent odours building up.

# Cleaning and care

## Cleaning the door seal

 Risk of damage as a result of incorrect cleaning.

If you treat the door seal with oils or grease, it can become porous.

Do not use any oils or grease on the door seal.

- The door seal should be cleaned regularly with clean water and then wiped dry with a cloth.

## Cleaning the ventilation gaps

A build-up of dust will increase the energy consumption of the appliance.

- The ventilation gaps should be cleaned on a regular basis with a brush or vacuum cleaner (e.g. use the dusting brush for Miele vacuum cleaners)

## After cleaning

- Replace all shelves and accessories in the appliance.
- Reconnect to the mains and switch the appliance back on.
- Switch on the Super cool function for a while so that the refrigerator section can cool down quickly.
- Place food in the refrigerator section and close the door.

## Replacing the charcoal filters

Charcoal filters and a KKF-FF (Active AirClean) holder are available as optional accessories (see “Accessories - optional accessories”).

Replace the charcoal filters in the holder every 6 months.

Replacement KKF-RF charcoal filters can be obtained from Miele, from your dealer or from Miele's website.

**Tip:** The charcoal filter holder is dishwasher-proof.

- Pull the charcoal filter holder upwards to remove it from the shelf.

When in position, the charcoal filters must not touch the back wall of the appliance as the moisture could cause them to stick to the back wall. Insert the new charcoal filters into the holder so that they do not protrude over the edge of the holder.



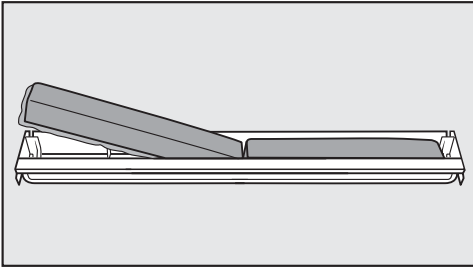

- Remove both charcoal filters and place the new filters with the framed edge pointing downwards in the holder.

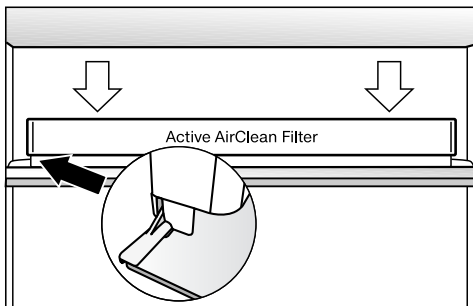

- Place the holder in the middle of the raised edge at the back of the shelf, so that it clicks into position.



## Problem solving guide

---

Many malfunctions and faults that can occur in daily operation can be easily remedied. Time and money will be saved because a service call will not be needed.

The following guide may help you to find the reason for a malfunction or a fault, and to correct it.

To prevent unnecessary loss of temperature it is advisable not to open the door while waiting for the appliance to be serviced.

Problem	Cause and remedy
<b>The appliance is not getting cold, the interior lighting does not come on when the door is opened, and the display is not lit up.</b>	The appliance is not switched on and the mains connection symbol  is lit up in the display. ■ Switch the appliance on.
	The plug is not inserted in the socket correctly. ■ Insert the plug correctly into the socket. The mains connection symbol  appears in the display when the appliance is switched off.
	Check whether the mains fuse has tripped. There could be a fault with the appliance, the household electrical wiring or another electrical appliance. ■ Contact a qualified electrician or Miele.
<b>The  symbol lights up in the display, the appliance does not get cold, although the controls and the interior lighting are working.</b>	Demo mode is switched on. This allows the appliance to be presented in the showroom without the cooling system being switched on. Do not activate this setting for domestic use. ■ Switch off Demo mode (see “Information for dealers - Demo mode”).

## Problem solving guide





Problem	Cause and remedy
<b>The compressor runs continuously.</b>	This is not a fault. To save energy, the compressor runs at a lower speed, but for longer, when less cooling is required.
<b>The compressor is switching on more frequently and for longer periods of time. The temperature in the refrigeration appliance is too low.</b>	The ventilation gaps in the housing unit have been covered or become too dusty. <ul style="list-style-type: none"> <li>■ Do not block the ventilation gaps.</li> <li>■ Dust the ventilation gaps regularly.</li> </ul>
	The appliance door has been opened too frequently or a large amount of food has been put in at once. <ul style="list-style-type: none"> <li>■ Only open the door when necessary and for as short a time as possible.</li> </ul> <p>After a while, the temperature will return to normal by itself.</p>
	The appliance door is not properly closed. <ul style="list-style-type: none"> <li>■ Close the door.</li> </ul> <p>After a while, the temperature will return to normal by itself.</p>
	The ambient room temperature is too high. The higher the ambient temperature, the longer the compressor has to run. <ul style="list-style-type: none"> <li>■ See the information in “Installation” – “Location”.</li> </ul>
	The refrigeration appliance was not properly installed in the niche. <ul style="list-style-type: none"> <li>■ See the information in “Installation” – “Installing the refrigeration appliance”.</li> </ul>
<b>The compressor is switching on more frequently and for longer periods of time, so the temperature in the appliance is dropping.</b>	The temperature setting is too low. <ul style="list-style-type: none"> <li>■ Adjust the temperature.</li> </ul>
	The Super cool function is still switched on. <ul style="list-style-type: none"> <li>■ You can switch off the Super cool function earlier to save energy.</li> </ul>
<b>The compressor comes on less and less often and for shorter periods of time.</b>	This is not a fault. The temperature is too high. <ul style="list-style-type: none"> <li>■ Adjust the temperature.</li> <li>■ Check the temperature again after 24 hours.</li> </ul>

# Problem solving guide

---



Problem	Cause and remedy
<p><b>An LED indicator light is flashing at the back of the appliance at the bottom near the compressor (depending on model).</b></p> <p><b>The electronic unit for the compressor is equipped with an operation and fault diagnosis LED indicator light.</b></p>	<p>The indicator light flashes several times every 5 seconds.</p> <p>A fault has occurred.</p> <ul style="list-style-type: none"><li>■ Call Miele.</li></ul>
	<p>The indicator light flashes regularly every 15 seconds.</p> <p>Not a fault. This flashing is normal.</p>

## Display warnings



Message	Cause and remedy
The alarm symbol  lights up in the display and an alarm sounds.	The <b>door alarm</b> has been activated. <ul style="list-style-type: none"><li>■ Close the appliance door. The alarm symbol  will go out, and the alarm will stop.</li></ul>
 lights up in the display.	The <b>Replace filter reminder</b> setting has been activated. This is the reminder to change the filter (Active AirClean). <ul style="list-style-type: none"><li>■ Replace the filter in the holder (see “Cleaning and care - Replacing the filter”).</li><li>■ Reset the counter (see “Selecting further settings - Filter replacement indicator ”).</li></ul>
“F0 to F9” appears in the display.	There is a fault. <ul style="list-style-type: none"><li>■ Call the Miele Service Department.</li></ul>

## Problem solving guide

### The interior lighting is not working.

Problem	Cause and remedy
<b>The interior lighting is not working.</b>	<p>The appliance has not been switched on.</p> <ul style="list-style-type: none"><li>■ Switch the appliance on.</li></ul>
	<p><b>Sabbath mode</b> is switched on: the display is dark and the appliance is cooling.</p> <ul style="list-style-type: none"><li>■ Touch the settings sensor to quit the Sabbath mode.</li></ul> <p>The temperature will then appear in the display and the interior lighting will come on (see “Selecting further settings” – “Switching Sabbath mode on/off”).</p>
	<p>To avoid overheating, the lighting switches itself off automatically after approx. 15 minutes if the door is left open. If this is not the case, then there is a fault.</p>
	<div data-bbox="404 671 1032 863" style="border: 1px solid gray; padding: 5px;"><p> <b>Danger of electric shock.</b> There are live electrical components under the lighting cover. The LED lighting may only be repaired or replaced by a Miele authorised service technician.</p></div> <div data-bbox="404 863 1032 1166" style="border: 1px solid gray; padding: 5px;"><p> <b>Danger of injury from LED lighting.</b> Light intensity corresponds to laser beam class 1/1M. The lighting covers must not be removed or damaged, or be removed due to damage. This could cause injury to your eyes. Do not look into the LED lighting (laser beam class 1/1M) with optical instruments (e.g. magnifying glass or similar).</p></div> <ul style="list-style-type: none"><li>■ Call Miele.</li></ul>

## Problem solving guide



Problem	Cause and remedy
<p><b>The LED lighting on one of the adjustable shelves is not working.</b></p>	<p>The shelf has not been positioned correctly on the shelf supports.</p> <ul style="list-style-type: none"> <li>■ Check that the shelf is positioned correctly on the shelf supports. The shelf has a metal disc (contacts) at the front left corner which supply power to the LED lighting.</li> <li>■ Push the shelf in until it clicks into position.</li> </ul>
	<p>The metal disc is not clean and dry.</p> <ul style="list-style-type: none"> <li>■ Clean it with a damp cloth and then dry with a lint-free cloth.</li> </ul>
	<p>The LED lighting on the stainless steel trim is faulty.</p> <div style="border: 1px solid gray; padding: 5px;"> <p> Risk of electric shock.</p> <p>There are live electrical components under the lighting cover.</p> <p>The LED lighting may only be repaired or replaced by Miele Service.</p> </div>
	<div style="border: 1px solid gray; padding: 5px;"> <p> Risk of injury from LED lighting. The light intensity corresponds to laser beam class 1/1M.</p> <p>The lighting covers must not be removed or damaged, or be removed due to damage. This could cause injury to your eyes.</p> <p>Do not look into the LED lighting (laser beam class 1/1M) with optical instruments (e.g. magnifying glass or similar).</p> </div> <ul style="list-style-type: none"> <li>■ Replace the adjustable shelf with LED lighting. A replacement is available from Miele Service.</li> </ul>

## Problem solving guide

Problem	Cause and remedy
<b>The LED lighting is not working on any of the shelves.</b>	<p>Liquid has been spilt onto the LED lighting on one of the shelves or the metal discs (contacts) in the left-hand shelf supports.</p> <p>The safety switch-off mechanism has switched off the LED lighting on all the shelves.</p> <ul style="list-style-type: none"><li>■ Wipe the stainless steel trim with LED lighting with a damp cloth and dry it or leave it outside the appliance to dry. Clean the metal discs (contacts) in the shelf supports in the same way.</li><li>■ Make sure that the contacts are clean and dry before replacing the shelves with LED lighting.</li><li>■ Push the shelf in until it clicks into position.</li><li>■ Close the appliance door.</li></ul> <p>The interior lighting will come on when the door is opened again.</p> <hr/> <p>If this is not the case, then there is a fault.</p> <ul style="list-style-type: none"><li>■ Call Miele.</li></ul>



## Other problems

Problem	Cause and remedy
The  symbol lights up in the display. You cannot switch the appliance off.	The <b>safety lock</b> has been activated. ■ Completely deactivate the safety lock (see “Selecting further settings – Activating and deactivating the safety lock”).
There is no audible alarm although the door has been open for a long time.	This is not a fault. The alarm tone has been switched off in settings mode (see “Selecting further settings – Audible signals  ”).
The external walls of the appliance feel warm.	This is not a fault. The heat created by the evaporator is used to prevent condensation.
The floor of the refrigerator section is wet.	The condensate drain hole is blocked. ■ Clean the condensate channel and drain hole.

# Noises

Normal noises	What causes them
<b>Brrrrr ...</b>	A humming noise is made by the motor (compressor). This noise can get louder for brief periods when the motor switches on.
<b>Blubb, blubb ...</b>	A gurgling noise can be heard when coolant is circulating through the pipes.
<b>Click ...</b>	Clicking sounds are made when the thermostat switches the motor on and off.
<b>Crack ...</b>	A cracking sound can be heard when materials expand inside the appliance.
Remember that the noise of the compressor and the coolant circulating in the system is unavoidable.	

Noises	Cause and remedy
<b>Rattling, vibrating</b>	The refrigeration appliance is uneven. Realign the appliance using a spirit level by raising or lowering the adjustable feet underneath the refrigeration appliance or placing something underneath it.
	The refrigeration appliance is touching another appliance or piece of furniture. Move it away.
	Drawers, baskets or shelves are jiggling or are stuck. Check all removable items and refit them correctly.
	Bottles or containers are touching each other. Separate them.

## Contact in case of malfunction

In the event of any faults which you cannot remedy yourself, please contact your Miele Dealer or Miele Service.

Contact information for Miele Service can be found at the end of this document.

Please note that telephone calls may be monitored and recorded for training purposes and that a call-out charge will be applied to service visits where the problem could have been resolved as described in this booklet.

Please quote the model and serial number of your appliance when contacting Miele. This information can be found on the data plate.

The data plate can be found inside the appliance.

## Warranty

The appliance warranty is valid for 2 years from date of purchase. In the UK, you must activate your cover by calling 0330 160 6640 or registering online at [www.miele.co.uk](http://www.miele.co.uk).

For more information on country-specific warranty terms and conditions, please contact Miele Customer Service.

## Information for dealers

---

### Demo mode

The appliance can be demonstrated in the showroom or at exhibitions in “Demo mode”. In this mode the control panel and interior lighting are active but the compressor remains switched off, so that the appliance does not cool down.

### Switching on demo mode



- Switch the appliance off by touching the On/Off sensor.  
If this does not work, the safety lock is activated.

The temperature display will go out and the mains connection symbol  will appear.







- Place your finger on the  sensor, and leave it there.



- At the same time, briefly touch the On/Off sensor (without letting go of the  sensor).



- Leave your finger on the  sensor until the  symbol appears in the display.
- Then release the  sensor.

Demo mode is turned on and the  symbol is illuminated in the display.

### Switching off Demo mode

The  symbol is lit up in the display.



- Touch the settings sensor.



All symbols available for selection will appear in the display and the  symbol flashes.



- Touch the sensors for setting the temperature ( $\nabla$  or  $\blacktriangle$ ) repeatedly until the  symbol flashes.



- Touch the OK sensor to confirm your selection.

 flashes in the display (means: Demo mode is switched on) and the  symbol lights up.



- Touch the  $\nabla$  or  $\blacktriangle$  sensor until  appears (means: Demo mode is switched off).



- Touch the OK sensor to confirm your selection.

The selected setting is applied, the  symbol flashes.



- Touch the settings sensor to leave settings mode. Otherwise the appliance exits settings mode automatically after approximately one minute.

Demo mode is switched off, the  symbol goes out.

# Installation

---

## Installation

 Danger of damage and injury due to the refrigeration appliance tipping over.

This refrigeration appliance is very heavy and can tip forwards when the appliance door is open.

Keep the appliance door(s) shut until the refrigeration appliance has been built in and secured in its housing in accordance with these operating and installation instructions.

 Fire risk and danger of damage from appliances which give off heat. Appliances which give off heat can catch fire and set fire to the refrigeration appliance.

This refrigeration appliance must not be installed underneath a hob.

 Fire risk and danger of damage from open flames.

Open flames can set fire to the refrigeration appliance.

Keep open flames (e.g. a candle) away from the refrigeration appliance.

## Side-by-side combinations

As a general rule, refrigeration appliances should not be installed vertically or horizontally next to other such appliances so as to avoid a build-up of condensation between them and the damage this can cause.

Your refrigeration appliance must not be installed next to another refrigeration appliance (“side-by-side”), or above another one, because it is not equipped with built-in heating units in the side panels.

It can, however, be installed next to another refrigeration appliance with built-in heating as long as they are in separate niches. Please contact your Miele retailer to find out which appliances are suitable for this method of installation.

## Location

This appliance should be installed in a dry, well-ventilated room.

When deciding where to install your refrigeration appliance please bear in mind that it will use more energy if installed near to a heater, a cooker or other appliance that gives off heat. Direct sunlight should also be avoided. The higher the room temperature, the longer the compressor runs and the higher the energy consumption is.

When installing the appliance, please note:

- The socket must be easily accessible in an emergency, not concealed behind the appliance.
- The plug and cable must not touch the rear of the appliance as they could be damaged by vibrations from the appliance.
- Do not plug in other appliances behind this appliance.

 Risk of damage due to high humidity.

In environments with high humidity, condensation can build up on external refrigeration appliance panels, which can cause corrosion.

Install the refrigeration appliance in a dry and/or air-conditioned room with sufficient ventilation.

After installation, make sure that the appliance door closes properly, the ventilation gaps are not covered and that the refrigeration appliance has been installed in accordance with these operating and installation instructions.

## Climate range

The appliance is designed for use within a certain climate range (ambient temperatures) and should not be used outside this range. The climate range of the appliance is stated on the data plate inside the appliance.

Climate range	Ambient room temperature
SN	+10 to +32 °C
N	+16 to +32 °C
ST	+16 to +38 °C
T	+16 to +43 °C

Operating in a room which is too cold will cause the compressor to switch off for too long, causing the internal temperature in the appliance to rise with the risk of food deteriorating and going off.

## Ventilation

 If the ventilation gaps given are not observed, the compressor will run more frequently and for longer periods.

This will result in increased energy consumption and a higher operating temperature for the compressor. This may, in turn, cause damage to the compressor.

It is essential to observe the ventilation gaps given.

Air at the back of the appliance gets warm. The appliance housing unit must therefore be constructed to allow sufficient space for ventilation (see “Building-in dimensions”).

# Installation

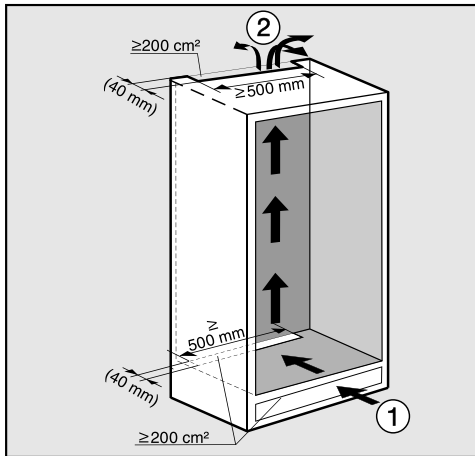

The air inlet and outlet must not be covered or blocked in any way. They must also be regularly cleaned of dust.

## Top ventilation gap

The ventilation gap at the top of the appliance can be constructed in different ways:

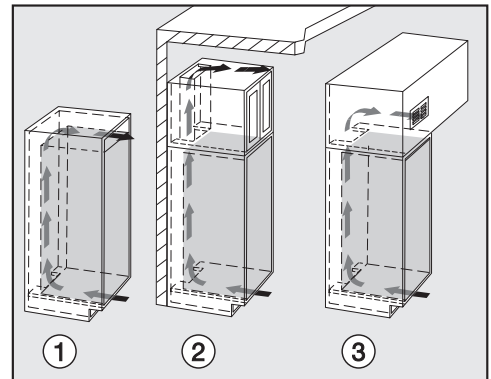

- Air intake ① occurs via the plinth at the bottom of the appliance and the air escapes at the top ② at the back of the housing unit.
- A ventilation gap of at least 40 mm depth must be allowed for behind the appliance for air to circulate.
- The ventilation cross-sections in the plinth, housing unit and above the appliance must each provide an unobstructed airflow of at least 200 cm<sup>2</sup> to ensure that air can circulate without hindrance.

- ① directly above the appliance with a ventilation grille (free airflow of at least 200 cm<sup>2</sup>)
- ② between the kitchen furniture and the ceiling
- ③ in a suspended ceiling

If ventilation grilles are to be inserted into the ventilation gaps, the ventilation gaps must be larger than 200 cm<sup>2</sup>. The unobstructed airflow of 200 cm<sup>2</sup> is calculated by adding up the total area of ventilation openings in the grilles.

- Important! The appliance uses less energy, the larger the ventilation gaps.



## Furniture door panel

### Horizontal and vertical gaps

Depending on the style of kitchen furniture the thickness and edge radius of the furniture door and the gap that runs around the door, vertically and horizontally, are specified.

It is essential to pay attention to the following!

#### – Horizontal gap

The gap between the appliance furniture door and the housing unit door above or below it must be at least 3 mm.

#### – Vertical gap

If the gap between the appliance furniture door and the adjoining housing unit door or wall on the hinged side is too small, the appliance door could collide with the adjoining housing unit door or wall when opened. It may be necessary to adjust the size of this gap to suit the thickness and edge radius of the appliance furniture door.

This must be taken into consideration when planning your kitchen and when replacing an old appliance with a new one to ensure the installation conditions required are met.

Appliance furniture door thickness <b>A</b> [mm]	Gap <b>X</b> [mm] for different edge radii <b>B</b>			
	R0	R1.2	R2	R3
≥16 - 19	Min. 3			
20	5	4	4	3.5
21	5.5	5	4.5	4
22	6.5	6	5.5	5

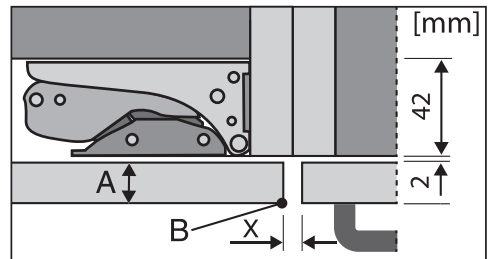

Adjoining kitchen furniture front

A = Furniture front thickness  
 B = Edge radius  
 X = Gap

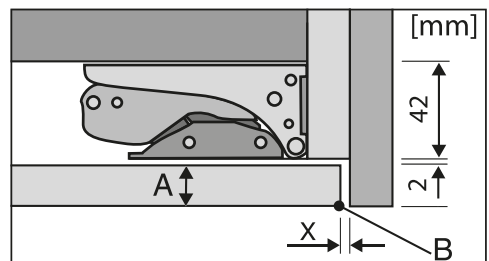

Adjoining side wall

A = Furniture front thickness  
 B = Edge radius  
 X = Gap

**Tip:** Fit a spacer between the housing unit carcass and the side wall. This way you will get a sufficiently wide gap.

# Installation

## Weight of the furniture door

⚠ If the furniture door panel is too heavy, this can cause damage. Fitting a furniture door panel which is heavier than the maximum permitted weight could damage the hinges. This can cause subsequent functional problems.

Before fitting a furniture door, ensure that the weight of the door does not exceed the maximum permitted:

Appliance	Maximum weight of furniture door in kg
K 34673 iD	19
K 35672 iD	21
K 35673 iD	21
K 37672 iD	26
K 37673 iD	26

## Fitting large or divided furniture doors

When fitting large or divided furniture doors an extra fitting kit or set of fixing brackets should be used. These are available to order from Miele.

## Before installing the appliance

- Take the accessory pack which includes installation parts and other accessories out of the appliance and remove the packaging strap holding the door in place.
- **Do not remove** the following from the back of the appliance:

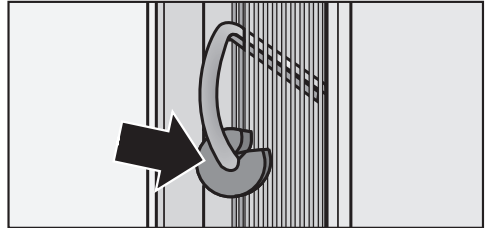

- The spacers (depending on model) These ensure the gap required between the back of the appliance and the wall is maintained.
- The bags (depending on model) located inside the metal grille (heat exchanger). These are important for the correct functioning of the appliance. Their contents are non-toxic and are not dangerous.
- Remove the cable clip from the back of the appliance.

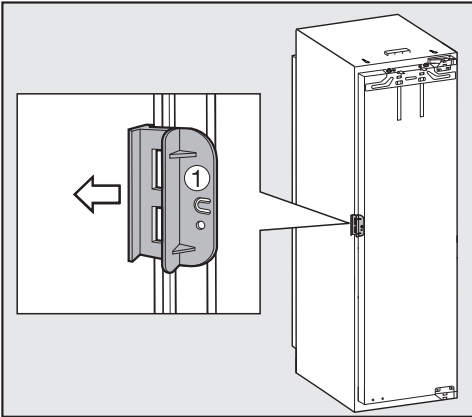

- Open the appliance door and remove the red safety catch ① (depending on model).

## Does your old appliance have a different hinging mechanism?

If your old appliance had a different type of hinging, the furniture door can still be used. Remove the old hinges from the housing unit. They are no longer required because the furniture door is now fitted to the appliance door. All the necessary parts are supplied or can be ordered from Miele.

## Stainless steel front

(depending on model)

If your old appliance had different hinging and you cannot, or do not wish to use your old door, you can use a stainless steel front instead.

Contact Miele for information on suitable stainless steel fronts.

# Installation

## Building-in dimensions

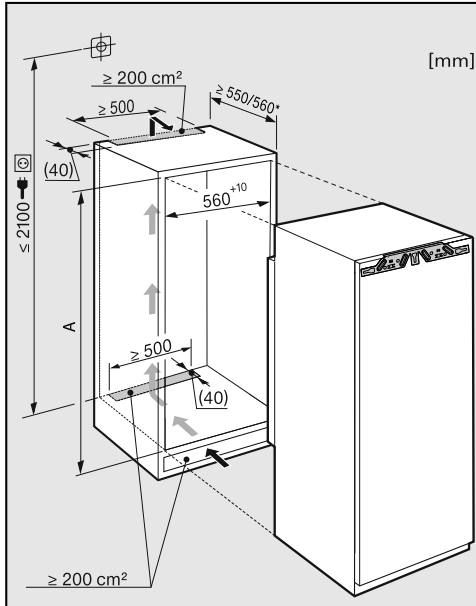

\* The declared energy consumption was calculated in a 560 mm deep niche. The appliance is fully functional in a 550 mm niche but the energy consumption will be slightly higher.

Before installation, ensure the housing unit is the correct size. The specified ventilation cross-sections must be maintained in order to ensure the correct functioning of the appliance.

	<b>Niche height [mm] A</b>
<b>K 34673 iD</b>	1,220–1,236
<b>K 35672 iD</b>	1,397–1,413
<b>K 35673 iD</b>	1,397–1,413
<b>K 37672 iD</b>	1,772–1,788
<b>K 37673 iD</b>	1,772–1,788

## Limiting the opening angle of the appliance door

The door hinges are set ex works to enable the appliance door to be opened wide.

However if the opening angle of the appliance door needs to be limited for any reason, the hinge can be adjusted to accommodate this.

If the appliance door hits an adjacent wall when opened, for example, the opening angle can be limited to approx. 90°:

The locking pins for limiting the door opening must be fitted before the refrigeration appliance is installed.

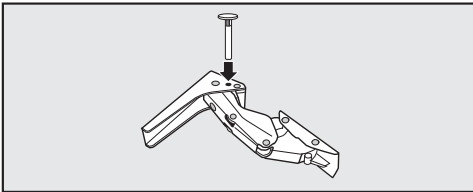

- Insert the locking pins supplied for limiting the door opening into the hinges from above.

The appliance door opening angle is now limited to approx. 90°.

## Changing the door hinging

Two people are needed for changing the door hinging.

The appliance is supplied right-hand hinged. If left-hand hinging is required, the hinges must be changed.

**To change the door hinging, you will need the following tools:**

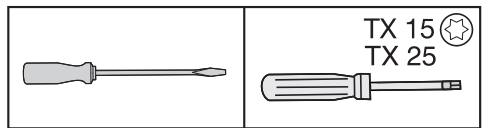

- Open the appliance door.
- Remove the shelves/bottle shelf from the appliance door.

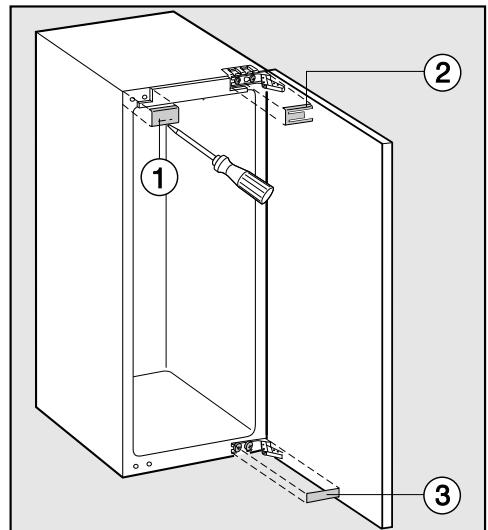

- Lift off covers ①, ② and ③.

# Installation

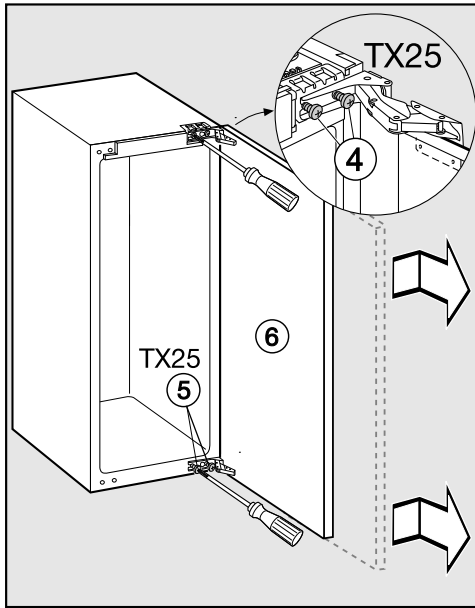

- Slightly loosen screws ④ and ⑤ in the hinges.
- Push door ⑥ outwards and take it off its hinges.

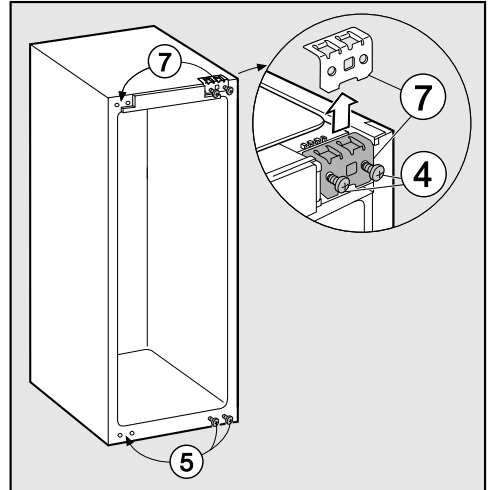

- Undo screws ④ completely.
- Fit bracket ⑦ on the opposite side and loosely fit screws ④.
- Remove screws ⑤ completely and loosely screw them in on the opposite side.

If you have put locking pins into the hinges to stop the door opening too far:

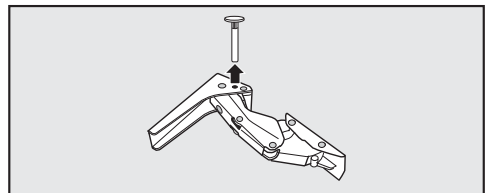

- Remove the locking pins from the top of the hinges.

## To remove the soft-close mechanism

**⚠ Warning.** The soft-close mechanism snaps shut when dismantled. Danger of injury.

- Place the door with the outer side downwards on a stable surface.

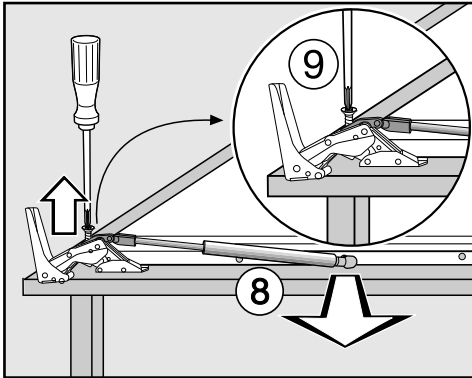

- Remove the soft-close mechanism (8) from the ball joint.
- Unscrew holder (9) and remove the soft-close mechanism (8).

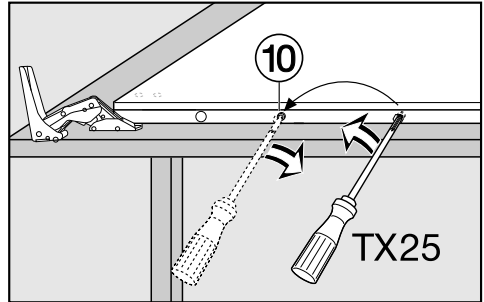

- Undo ball joint (10) using a screwdriver and reposition and secure it as shown.
- Now turn the appliance door over so that the outer side is now facing upwards (the hinges remain open).

**Danger of injury.**  
**Do not** close the hinges.

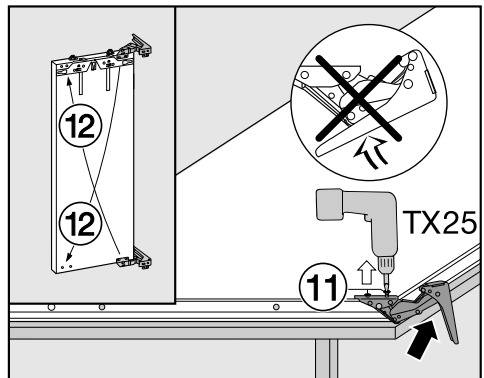

- Remove screws (11) completely.
- Replace the hinges in their diagonally opposite corners (12).





## Installing the appliance

Two people are required for installing the appliance.

- Install the appliance in a stable, solid housing unit, positioned on an even and level floor.
- Secure the housing unit against tipping.

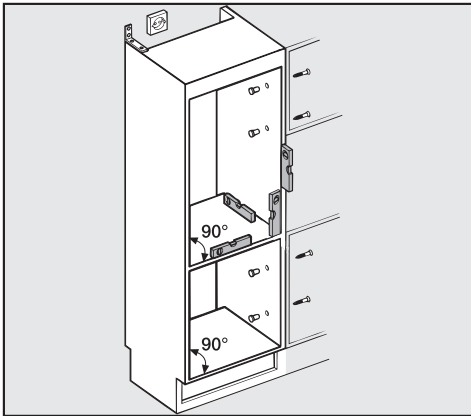

- Use a spirit level to align the housing unit. The corners of the housing unit must be at 90° angles to each other, otherwise the door will not sit straight on all 4 corners.
- The required ventilation gaps must be provided (see “Installation” – “Installation notes”).

To install the appliance, you will need the following tools:

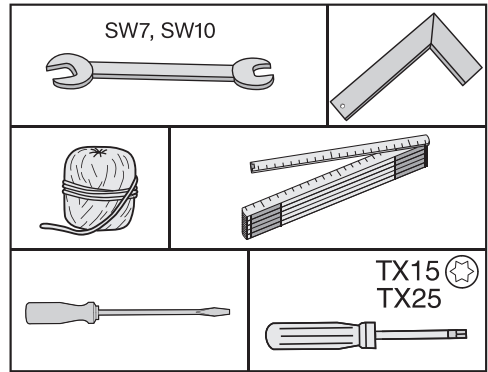





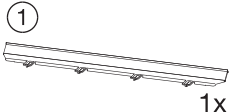
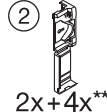

# Installation

## Parts required for installation:

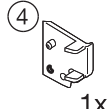
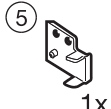
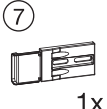
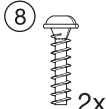
All installation parts are number coded. This coding is also used in the installation instructions.

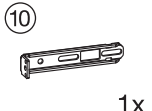
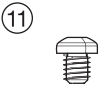

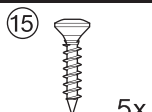
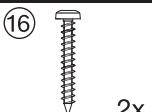
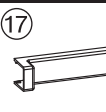
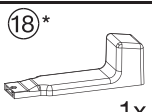
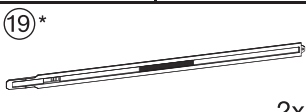
### – For installing the appliance in its housing unit:

 1x	 2x+4x**	 2x+4x**	
 1x	 1x	 1x	 2x
 1x	 1x	 2x	
 1x			
 5x	 2x	 1x	
 1x	 2x		

\* These parts are only supplied with appliances with a niche height of 140 cm or more.

\*\* Quantity depends on niche height; max. quantity applies to appliances requiring niche height of 140 cm or more (also contains additional installation parts for fitting large or divided furniture doors).

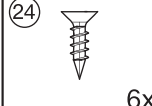
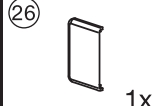
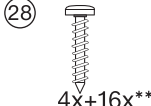
### – For fitting the furniture door:

 6x	 1x	 4x+16x**
 1x		

\*\* Quantity depends on niche height. Also contains additional installation parts for fitting large or divided furniture doors.

All fitting instructions given are for a **right-hand hinged** appliance. If you have converted the appliance to left-hand hinging, you will need to adapt these instructions accordingly.

## Preparing the appliance

- Position the appliance in front of the housing unit.

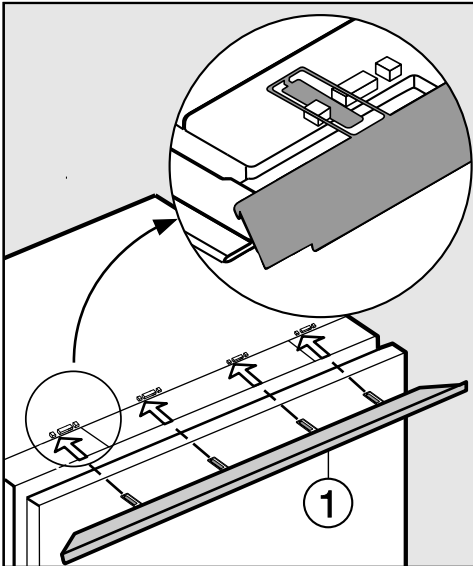

- Slide the cover strip ① into the holders as shown.

If the appliance is hinged on the left, slide the tabs of the cover strip into the right-hand opening of the holder.

 Risk of damage to the fixing bracket and cover.

The cover on the fixing bracket can easily become detached.

Always close the cover as soon as you have finished working on the bracket.

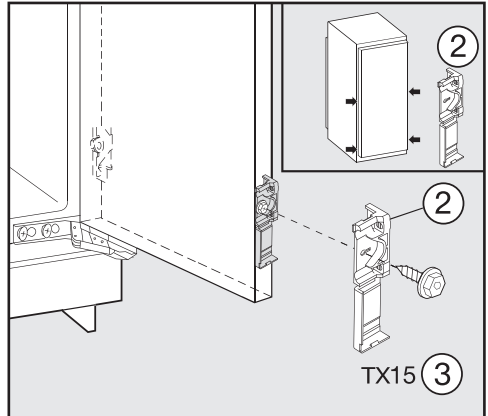

- Loosely screw the fixing brackets ② into the pre-drilled holes in the appliance door using hex screws ③.

**Tip:** Secure a pair of fixing brackets in the handle area of the door.

# Installation

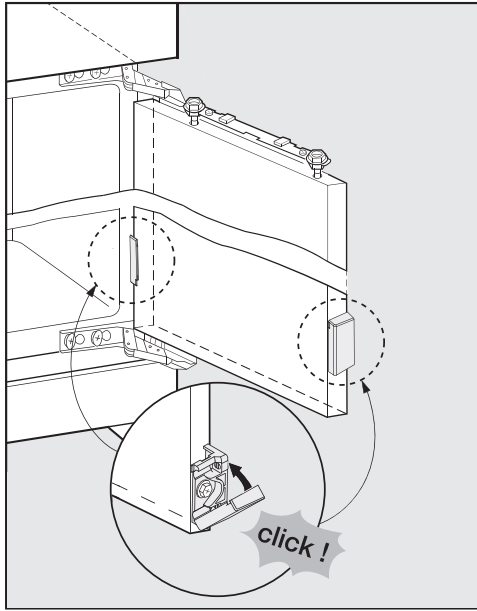

- Close the covers.
- Push the appliance two thirds of the way into the building-in niche. When pushing the appliance into its niche, make sure that the mains cable does not get trapped.

**Tip:** To help you push it into position, tie a piece of string around the plug to “lengthen” the power cable. Then pull the cable by the end of the string through the housing unit. It will then be easier to connect once the appliance is in the unit.

**With 16 mm thick unit walls only:**

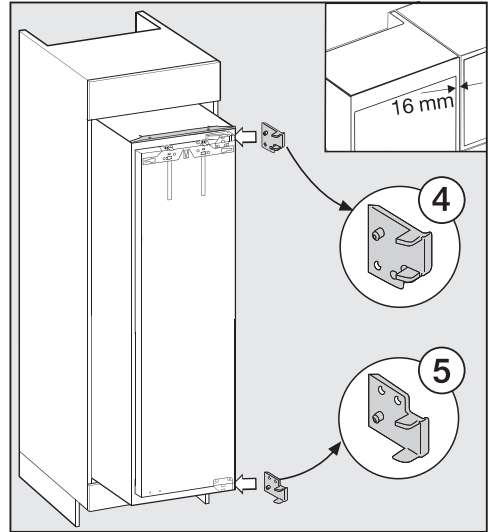

- Clip spacers ④ and ⑤ on the right-hand side of the hinges.
- Open the appliance door.

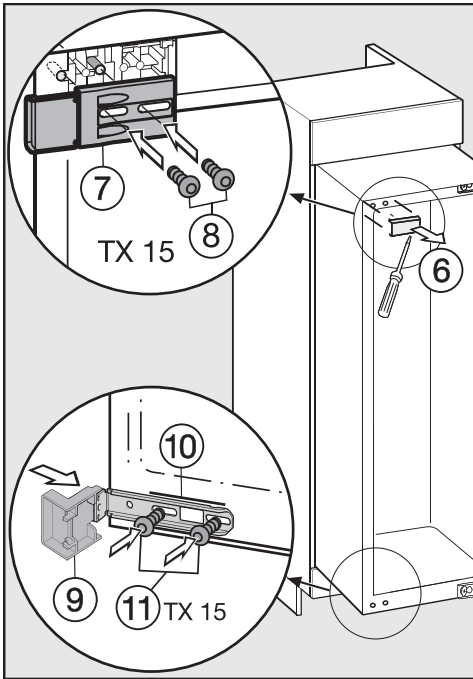

- Remove the cover ⑥.
- Loosely fit the connecting bracket ⑦ using the screws ⑧.

**Tip:** Do not tighten the screws so that you can adjust the position of the connecting bracket.

- Fit the stopper ⑨ onto the fixing bracket ⑩.
- Loosely fit the fixing bracket ⑩ using the screws ⑪.

**Tip:** Do not tighten the screws so that you can adjust the position of the connecting bracket.

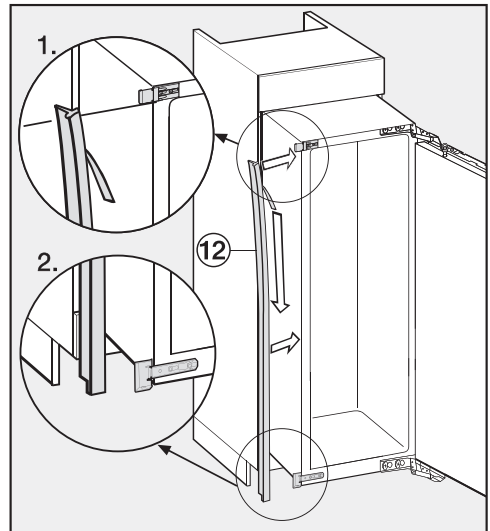

- Carefully remove the protective foil from the sealing strip ⑫.
  - Fix the sealing strip ⑫ flush with the front of the appliance on the door opening side.
1. Position the sealing strip flush with the lower edge of the top connecting bracket.
  2. Stick it down along its entire length.

## Installing the appliance

If the appliance is pushed too far into the niche, the appliance doors may not close properly once the furniture door has been fitted. This can cause ice to build up, condensate to accumulate and lead to faults in the appliance. These can all lead to increased energy consumption.

Push the appliance into the building-in niche making sure a gap of **42 mm** is maintained all round between the appliance carcass and the front of the housing unit side walls.

# Installation

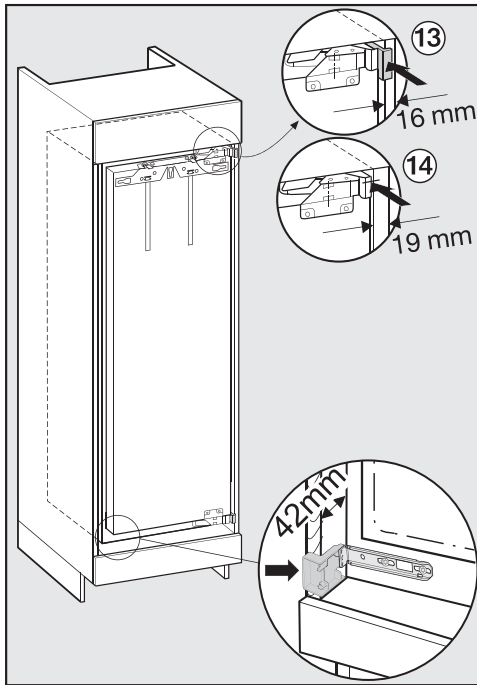

Important for furniture with door fittings (e.g. stubs, seals, etc.).

Take the dimensions of the fittings into account.

Check to make sure there is a gap all round of **42 mm** to the front edges of the door fittings.

- Pull the refrigeration appliance forwards by the appropriate dimension.

**Tip:** If possible, remove the door fittings and push the refrigeration appliance into the niche until all fixing brackets at the top and bottom are touching the front edge of the housing unit side wall.

- Push the appliance into the niche until all fixing brackets at the top and bottom are in line with the front edge of the housing unit side wall.

- **13 With 16 mm thick walls:**  
The spacers should touch the front edge of the housing unit side walls at the top and bottom.
- **14 With 19 mm thick walls:**  
The front edges of the top and bottom hinges should be flush with the front edge of the housing unit side wall.

This will create a gap all round of **42 mm** to the front edges of the housing unit side walls.

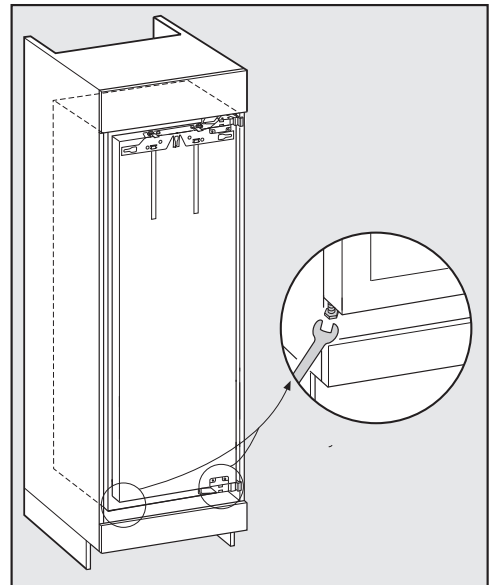

- Align the appliance on both sides by altering the adjustable feet using the spanner supplied.

## Securing the refrigeration appliance in the niche

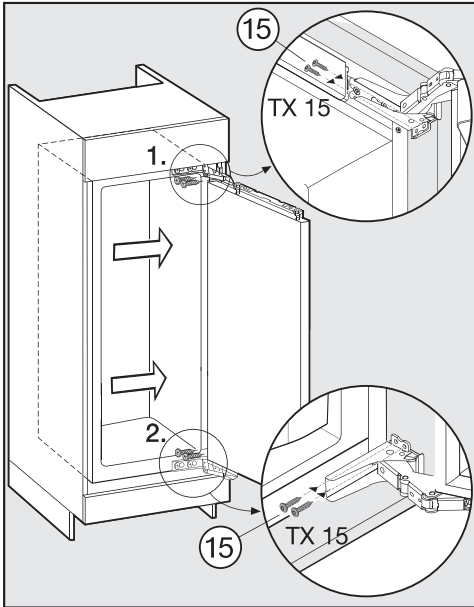

- Press the appliance against the side of the housing unit on the hinge side.
- Screw the chipboard screws ⑮ through the hinge plates at the top and bottom to secure the appliance to the housing unit.

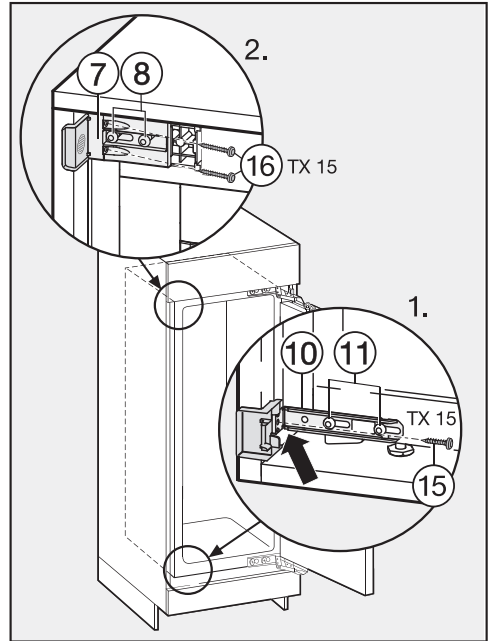

- Push the loose fixing brackets against the housing unit wall.
- Secure the fixing bracket ⑩ to the housing unit side wall with the screw ⑮.

**Tip:** Pre-drill the hole.

The appliance must not pull back into the unit, as otherwise the gap of 42 mm will not be maintained all the way round.

Using your thumb, push the protruding bracket towards the housing unit wall whilst tightening the screws.

- Secure the fixing bracket ⑦ to the housing unit side wall with the screws ⑯.

**Tip:** Pre-drill the holes.

- Re-tighten screws ⑧ and ⑪.

# Installation

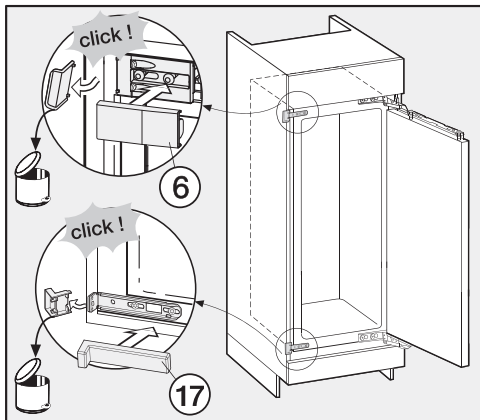

- Snap off any protruding ends from the fixing brackets. They are no longer required and can be disposed of.
- Replace covers ⑥ and ⑰ on the fixing brackets.

## Only for an appliance with a niche height greater than 140 cm

To enhance the stability of the appliance in the unit, push the rods supplied in underneath the appliance between it and the floor of the housing unit:

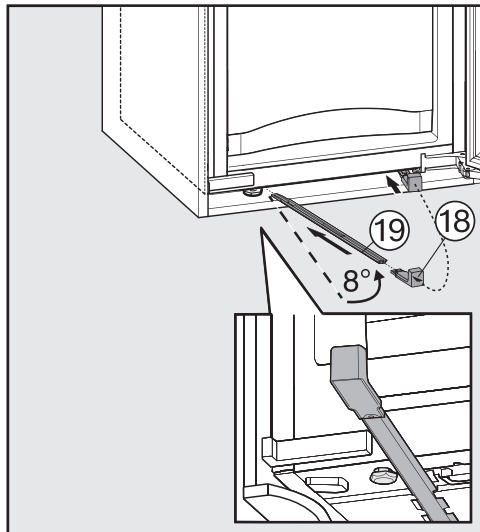

- First secure the handle ⑱ to one of the stabilising rods ⑲.
- Push the stabilising rod ⑲ into the guide hole as far as it will go. Remove the handle ⑱, fit it to the other rod supplied and push this into its guide as far as it will go.

**Tip:** Keep the handle somewhere safe in case you ever need to fit the appliance into a new housing unit.

- Close the appliance doors.



## Fitting the furniture door

If fitted in a run of units make sure that the top edge of the furniture door is at the same height as neighbouring unit doors.

The furniture door must be fitted correctly and not under tension.

The next section gives instructions on how to fit a furniture door that is at least 16–19 mm thick.

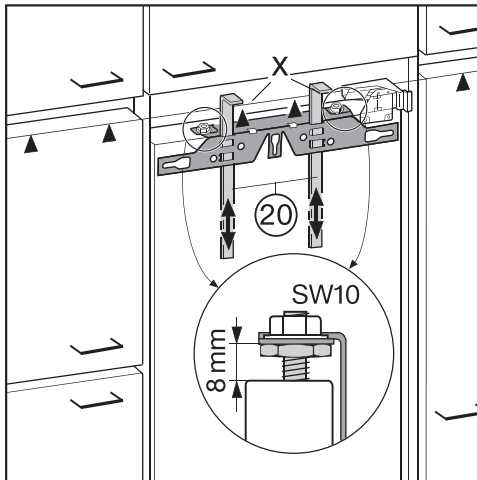

- The distance between the appliance door and the fixing bracket is set to 8 mm at the factory. Check this distance and adjust it if necessary.
- Push the fitting aids ⑳ up to the height of the furniture door: the lower edge X of the fitting aids must be at the same height as the upper edge of the furniture door being fitted (see ▲ in diagram).

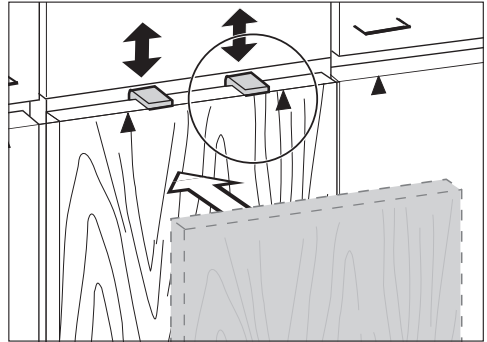

**Tip:** Push up the fitting aids with the furniture front until they are at the same height as the doors of adjacent kitchen units.

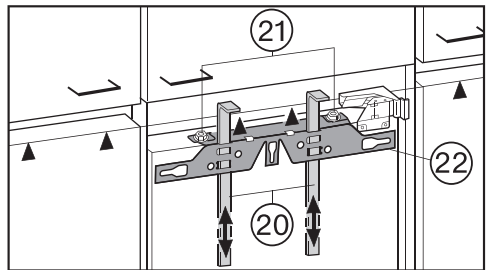

- Undo the nuts ⑳ and take the fixing bracket ㉓ off together with the fitting aids ㉒.

# Installation

- Place the furniture door with the outer side downwards on a stable surface.

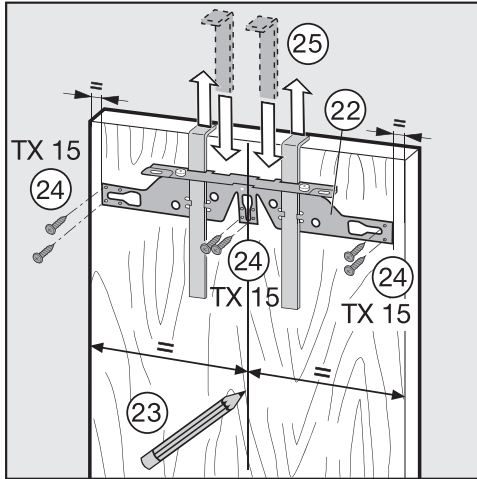

- Using a pencil, lightly mark a line down the centre of the inside of the furniture door (23).
- Hang the fixing bracket (22) with the fitting aids onto the **inside** of the furniture door. Align the fixing bracket centrally.
- Attach the fixing bracket securely using at least 6 short chipboard screws (24). (On cassette doors only use 4 screws on the edges).

**Tip:** Pre-drill the holes.

- Pull the fitting aids upwards to remove them (25). Turn them around and fit them into the middle slots on the fixing bracket for safe keeping.

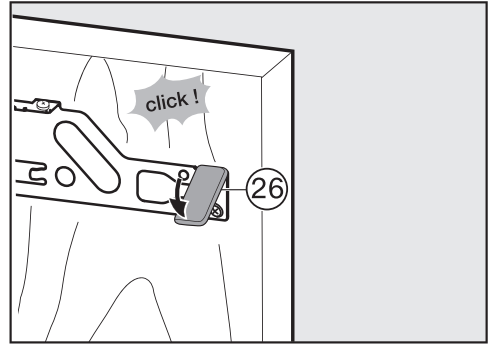

- Slide the side cover (26) onto the fixing bracket on the side opposite the hinge.
- Turn the furniture door over and attach the handle (if required).

- Open the appliance door.

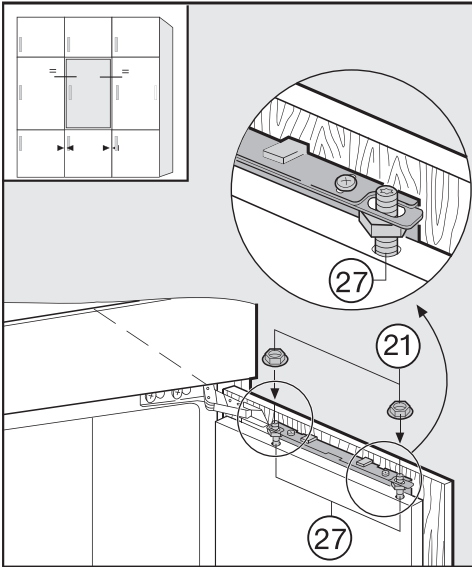

- Hang the furniture door onto the adjusting bolts (27).
- Loosely attach the nuts (21) on the adjusting bolts.

## Aligning the door

Check the distance between the door and adjacent furniture doors. The distance should be the same.

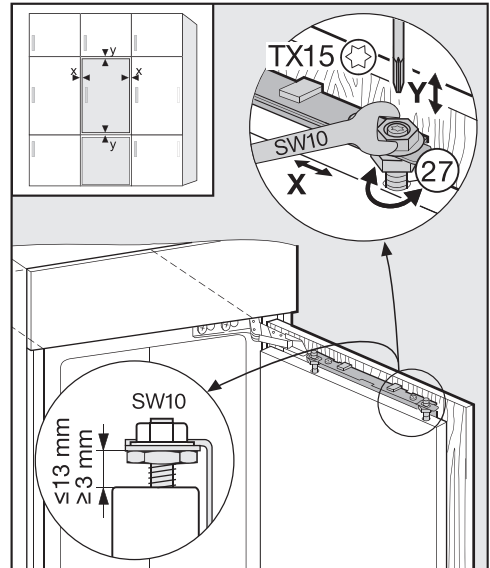

### X: side adjustments

- Slide the furniture door.

### Y: height adjustment

A gap of 8 mm is set between the appliance door and the fixing bracket. This must only be adjusted within its permitted range.

- Use a screwdriver to adjust the bolts (27).

# Installation

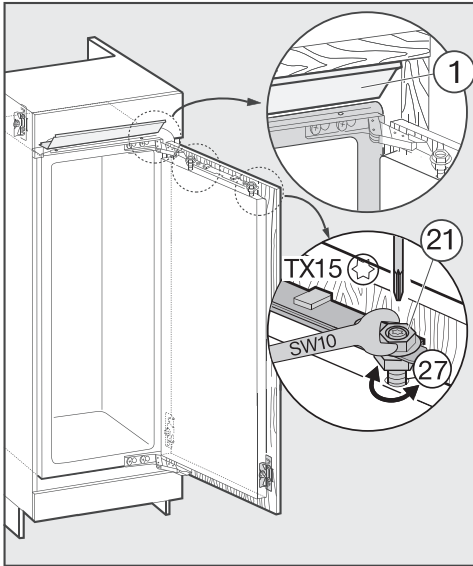

- Whilst counterholding the adjusting bolts ⑳ with a screwdriver, tighten the nuts ㉑ with a spanner.
- The cover strip ① must be completely hidden in the niche and must not protrude.

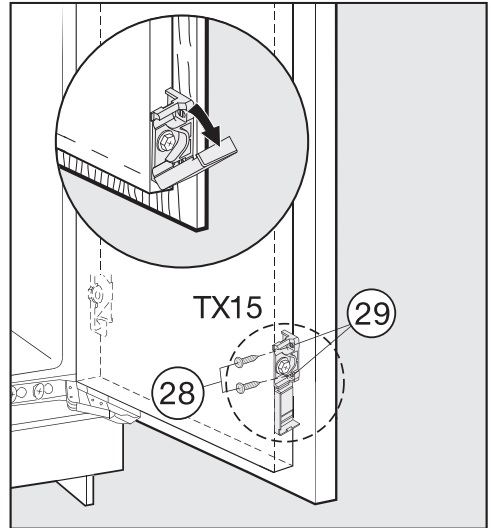

- Open the cover.
- Fit the screws ㉒ into the holes ㉓.

**Tip:** Pre-drill the holes.

⚠ Risk of damage to the fixing bracket and cover.

The cover on the fixing bracket can easily become detached.

Always close the cover as soon as you have finished working on the bracket.

- Close the door.

## Z: depth adjustment

Check the distance between the furniture door and the housing unit. A distance of approx. 2 mm is required.

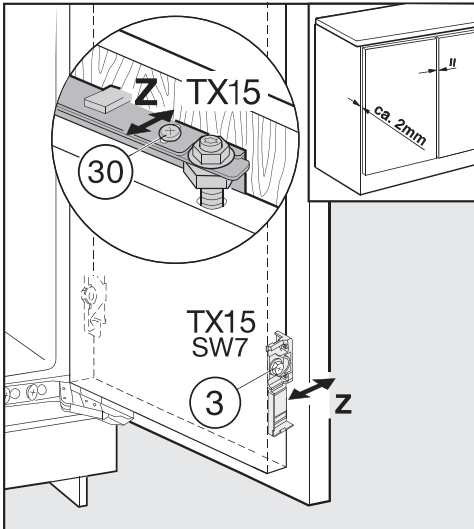

- Loosen the screws (3) at the top of the appliance door and the screw (30) at the bottom of the fixing bracket.
- Tighten all the screws again.

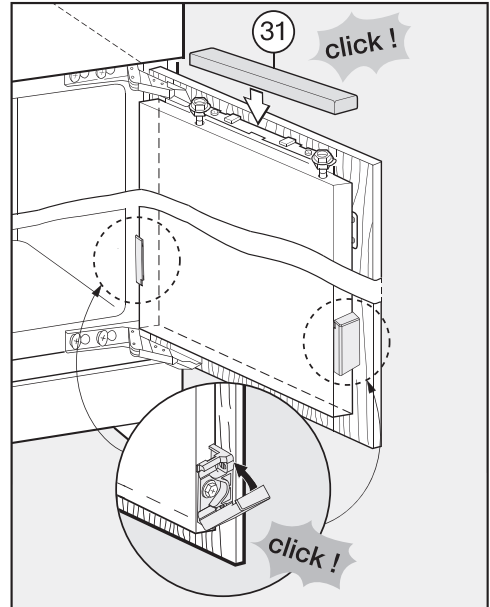

- Replace the cover (31) and click it into place.
- Close the covers on the fixing brackets.

# Installation

---

## **To make sure the appliance is correctly fitted:**

- The door must close properly.
- The door must not touch the housing unit.
- The seal at the top edge of the handle side must fit properly.
- To double check place a torch in the appliance and close the door. Turn the lights out in the room. If you can see any light shining out from the sides double check the installation.

## Electrical connection

The appliance is supplied with a mains cable and moulded plug ready for connection to an AC single-phase 220–240 V 50 Hz supply.

The fuse rating must be at least 10 A.

This appliance must be connected to a suitable switched socket. The electrical installation must be in compliance with current local and national safety regulations, (e.g. VDE 0100 in Germany / BS 7671 in the UK).

The socket must not be concealed behind the appliance and must be easily accessible so that the appliance can be quickly disconnected from the electrical supply in case of an emergency.

If the socket is no longer accessible after installation, an additional means of disconnection must be provided for all poles. Suitable means of disconnection include switches with an all-pole contact gap of at least 3 mm. These include miniature circuit breakers, fuses and contactors (EN 60335).

The mains plug and mains connection cable must not come into contact with the back of the appliance as vibrations can cause damage to these components. This could result in a short circuit.

Do not plug in other appliances behind this appliance.

Do not connect the appliance to the mains electricity supply by an extension lead. Extension leads do not guarantee the required safety of the appliance (e.g. danger of overheating).

Do not connect the appliance to a stand-alone inverter such as those used with an autonomous energy source e.g. **solar power**.

When the appliance is switched on, power surges could result in a safety switch-off. This could damage the electronic module. The appliance must not be used with so-called **energy saving devices** either. These reduce the amount of energy supplied to the appliance, causing it to overheat.

If the mains cable needs to be replaced, this must be performed by a qualified electrician.









## United Kingdom

Miele Co. Ltd.  
Fairacres, Marcham Road  
Abingdon, Oxon, OX14 1TW  
Tel: 0330 160 6600  
Internet: [www.miele.com](http://www.miele.com)

## Australia

Miele Australia Pty. Ltd.  
ACN 005 635 398  
ABN 96 005 635 398  
1 Gilbert Park Drive  
Knoxfield, VIC 3180  
Tel: 1300 464 353  
Internet: [www.miele.com.au](http://www.miele.com.au)

## China

Miele (Shanghai) Trading Ltd.  
1-3 Floor, No. 82 Shi Men Yi Road  
Jing' an District  
200040 Shanghai, PRC  
Tel: +86 21 6157 3500  
Fax: +86 21 6157 3511  
E-mail: [info@miele.cn](mailto:info@miele.cn)  
Internet: [www.miele.cn](http://www.miele.cn)

## Miele (Hong Kong) Limited

41/F - 4101, Manhattan Place  
23 Wang Tai Road  
Kowloon Bay, Hong Kong  
Tel: (852) 2610 1025  
Fax: (852) 3579 1404  
Email:  
[customerservices@miele.com.hk](mailto:customerservices@miele.com.hk)  
Website: [www.miele.hk](http://www.miele.hk)

## India

Miele India Pvt. Ltd.  
Ground Floor  
Copia Corporate Suites  
Plot No. 9, Jasola  
New Delhi - 110025  
Tel: 011-46 900 000  
Fax: 011-46 900 001  
E-mail: [customercare@miele.in](mailto:customercare@miele.in)  
Internet: [www.miele.in](http://www.miele.in)

## Ireland

Miele Ireland Ltd.  
2024 Bianconi Avenue  
Citywest Business Campus  
Dublin 24  
Tel: (01) 461 07 10  
Fax: (01) 461 07 97  
E-Mail: [info@miele.ie](mailto:info@miele.ie)  
Internet: [www.miele.ie](http://www.miele.ie)

## Malaysia

Miele Sdn Bhd  
Suite 12-2, Level 12  
Menara Sapura Kencana  
Petroleum  
Solaris Dutamas No. 1  
Jalan Dutamas 1  
50480 Kuala Lumpur, Malaysia  
Phone: +603-6209-0288  
Fax: +603-6205-3768

## New Zealand

Miele New Zealand Limited  
IRD 98 463 631  
Level 2, 10 College Hill  
Freemans Bay, Auckland 1011  
New Zealand  
Tel: 0800 464 353  
Internet: [www.miele.co.nz](http://www.miele.co.nz)

## Singapore

Miele Pte. Ltd.  
163 Penang Road  
# 04 - 03 Winsland House II  
Singapore 238463  
Tel: +65 6735 1191  
Fax: +65 6735 1161  
E-Mail: [info@miele.com.sg](mailto:info@miele.com.sg)  
Internet: [www.miele.sg](http://www.miele.sg)

# Miele

## South Africa

Miele (Pty) Ltd  
63 Peter Place, Bryanston 2194  
P.O. Box 69434, Bryanston 2021  
Tel: (011) 875 9000  
Fax: (011) 875 9035  
E-mail: [info@miele.co.za](mailto:info@miele.co.za)  
Internet: [www.miele.co.za](http://www.miele.co.za)

## Taiwan

K.E. & Kingstone Co., Ltd.  
6th Fl., No. 120, Sec. 2  
Jianguo N. Rd.  
Taipei, Taiwan  
TEL: +886 2 2502-7256  
FAX: +886 2 2502-3077  
E-mail: [kenk@kenk.com.tw](mailto:kenk@kenk.com.tw)  
Website:  
[www.kenk.com.tw/ke/miele](http://www.kenk.com.tw/ke/miele)

## Thailand

BHIRAJ TOWER at EmQuartier  
43rd Floor Unit 4301-4303  
689 Sukhumvit Road  
North Klontong Sub-District  
Vadhana District  
Bangkok 10110, Thailand

## United Arab Emirates

Miele Appliances Ltd.  
Showroom 1  
Eiffel 1 Building  
Sheikh Zayed Road, Umm Al Sheif  
P.O. Box 114782 - Dubai  
Tel. +971 4 3044 999  
Fax. +971 4 3418 852  
800-MIELE (64353)  
E-Mail: [info@miele.ae](mailto:info@miele.ae)  
Website: [www.miele.ae](http://www.miele.ae)

**Manufacturer:** Miele & Cie. KG, Carl-Miele-Straße 29, 33332 Gütersloh, Germany

K 34673 iD, K 35672 iD, K35673 iD, K 37672 iD, K 37673 iD