

Miele



Operating and installation Instructions Commercial Tumble Dryers PDR 514/518/522/528/544

To avoid the risk of accidents or damage to the appliance, it is **essential** to read these instructions before it is installed and used for the first time.

en-AU, NZ

M.-Nr. 11 865 312

Caring for the environment

Disposal of the packing material

The packaging material protects the appliance from transport damage. The packaging materials used are selected from materials which are environmentally friendly for disposal and should be recycled.

Recycling the packaging reduces the use of raw materials in the manufacturing process and also reduces the amount of waste in landfill sites. Ensure that any plastic wrappings, bags etc. are disposed of safely and kept out of the reach of babies and young children. Danger of suffocation!

Disposing of your old machine

Old electrical and electronic machines often contain valuable materials. However, they also contain harmful substances which were essential for their correct functioning and safety. These could be hazardous to human health and to the environment if disposed of with general waste or if handled incorrectly. Therefore, please do not dispose of your old machine with household waste.

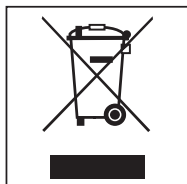

Instead, please make use of officially designated collection and disposal points to dispose of and recycle electrical and electronic machines in your local community. Ask your dealer for more information.

Please ensure that your old machine poses no risk to children while being stored for disposal.

Caring for the environment	2
Warning and Safety instructions	5
Correct application	5
Preventing problems	6
Technical safety	7
Correct use	9
Accessories	10
Guide to the machine	11
Operating the tumble dryer	12
Machines with residual moisture control (ROP)	12
Drying levels	13
Drying programmes	13
Machines with time control (TOP)	14
Drying levels (TOP)	15
Machines with payment systems (COP)	16
Drying programmes	17
How the control panel works	18
Indicators	18
Using for the first time	20
Drying	21
1. Notes on correct laundry care	21
Washing before drying	21
Removing foreign objects	21
Care symbols	21
2. Loading the tumble dryer	21
3. Selecting a programme	22
Selecting a programme	22
“Bedding” optional function	22
Drying level for programmes with a selectable drying level	22
Timed drying programmes and other programmes	23
Selecting Delay start	23
4. Starting a programme	24
5. End of the programme – unloading the drum	25
At the end of the programme	25
Removing the laundry	25
Care notes	25
Changing the programme sequence	26
Changing a programme after it has started	26
Adding or removing laundry	26
Time left	26
Supervisor level (programming mode)	27
Requirements for accessing supervisor level	27
Accessing supervisor level	27
Overview of supervisor level	27
Heater bank temperature	32
Process air temperature	33
Reversing cycle	34
Pauses	36
Fan pulsed operation after start	36

Contents

Quitting programming mode	38
Cleaning and care	39
Cleaning the fluff filter	39
Additional annual cleaning	40
Problem solving guide	41
Troubleshooting	41
After sales service	43
Contact in case of fault.....	43
Optional accessories	43
Installation	44
Installation requirements	44
General operating conditions	44
Transport.....	44
Installing the tumble dryer	44
Securing the tumble dryer.....	46
Electrical connection	46
Supply air/Exhaust air.....	47
Steam connection (only for steam-heated variants).....	47
Hot water connection (only for hot water-heated variants).....	47
Gas connection (only for gas-heated variants)	48
Networking	49
Pairing instructions	49
Optional accessories	51
Communication box.....	51
APCL106.....	51
Payment system	52
Original spare parts and accessories	52
Technical data	53

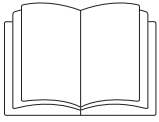

- ▶ It is essential to read these instructions.

This tumble dryer complies with all current local and national safety requirements. However, inappropriate use can lead to personal injury and damage to property.

Read the operating instructions carefully before using the tumble dryer. They contain important information on safety, installation, use and maintenance of the appliance. This prevents both personal injury and damage to the tumble dryer.

In accordance with standard IEC 60335-1, Miele expressly and strongly advises that you read and follow the instructions in “Installation”, as well as in the “Warning and Safety instructions”.

Miele cannot be held liable for injury or damage caused by non-compliance with these instructions.

Keep these operating instructions in a safe place and pass them on to any future owner.

When instructing other people how to use the tumble dryer, they must be made aware of these Warning and Safety instructions.

Correct application

- ▶ IF IT IS UNAVOIDABLE THAT FABRICS THAT CONTAIN VEGETABLE OR COOKING OIL OR HAVE BEEN CONTAMINATED BY HAIR CARE PRODUCTS ARE PLACED IN A TUMBLE DRYER THEY SHOULD FIRST BE WASHED IN HOT WATER WITH EXTRA DETERGENT - THIS WILL REDUCE, BUT NOT ELIMINATE, THE HAZARD.
- ▶ THIS APPLIANCE SHALL NOT BE USED TO DRY OFF SOLVENTS OR DRY CLEANING FLUIDS.
- ▶ OIL-AFFECTED ITEMS CAN IGNITE SPONTANEOUSLY, ESPECIALLY WHEN EXPOSED TO HEAT SOURCES SUCH AS IN A DRYER. THE ITEMS BECOME WARM, CAUSING AN OXIDATION REACTION IN THE OIL. OXIDATION CREATES HEAT. IF THE HEAT CANNOT ESCAPE, THE ITEMS CAN BECOME HOT ENOUGH TO CATCH FIRE. PILING, STACKING OR STORING OIL-AFFECTED ITEMS CAN PREVENT HEAT FROM ESCAPING AND SO CREATE A FIRE HAZARD.
- ▶ ADEQUATE VENTILATION SHALL BE PROVIDED TO AVOID THE BACK FLOW OF GASES INTO THE ROOM FROM ANY FUEL BURNING APPLIANCES, INCLUDING OPEN FIRES.
- ▶ THIS APPLIANCE REQUIRES PERMANENT VENTILATION FOR THE ROOM WHERE IT IS INSTALLED.
- ▶ THE DRYER IS NOT TO BE USED IF INDUSTRIAL CHEMICALS HAVE BEEN USED FOR CLEANING.
- ▶ DO NOT USE AN UNLINED MASONRY CHIMNEY AS THE FLUE FOR THIS APPLIANCE.
- ▶ Items such as foam rubber (latex foam), shower caps, waterproof textiles, rubber backed articles and clothes or pillows fitted with foam rubber pads should not be dried in the tumble dryer.
- ▶ Fresh air ventilation openings shall not be blocked and/or sealed.
- ▶ Items that have been soiled with substances such as cooking oil, acetone, alcohol, petrol, kerosene, spot removers, turpentine, waxes and wax removers should be washed in hot water with heavy-duty detergents where necessary to clean heavily soiled garments before being dried in the tumble dryer. If necessary, consult the detergent manufacturer.
- ▶ Do not dry unwashed items in the tumble dryer.

Warning and Safety instructions

- ▶ DO NOT MODIFY THIS APPLIANCE.
- ▶ DO NOT SPRAY AEROSOLS IN THE VICINITY OF THIS APPLIANCE WHILE IT IS IN OPERATION.
- ▶ DO NOT PLACE ARTICLES ON OR AGAINST THIS APPLIANCE.
- ▶ The tumble dryer is intended for use in a commercial environment.
- ▶ The dryer is intended exclusively for drying textiles washed in water which have been labelled as suitable for tumble drying by the manufacturer on the care label. Any other applications may be dangerous. Miele cannot be held liable for damage resulting from incorrect or improper use or operation.
- ▶ This tumble dryer is not suitable for outdoor use.
- ▶ Do not install the tumble dryer in a room where there is a risk of frost. At temperatures around freezing point, the tumble dryer may not be able to operate properly. The permitted room temperature is between 2°C and 40°C.
- ▶ If the machine is used in a commercial environment, it may only be operated by instructed/trained personnel. If the machine is to be operated in an area accessible to the public, the supervisor must ensure that it can be operated safely without risk of danger to others.
- ▶ This appliance is not intended for use by persons (including children) with reduced physical, sensory or mental capabilities, or lack of experience or knowledge, unless they are supervised whilst using it or have been shown how to use it in a safe way and understand and recognise the consequences of incorrect operation.
- ▶ Young children must not be allowed to use this appliance.
- ▶ Older children may only use the dryer if its operation has been clearly explained to them and they are able to use it safely. They must be able to understand and recognise the possible dangers of misuse.
- ▶ Children must not be allowed to clean or maintain the tumble dryer unsupervised.
- ▶ Children should be supervised in the vicinity of the tumble dryer. Do not allow them to play with the appliance.
- ▶ This tumble dryer may also be operated in public areas such as launderettes.
- ▶ Uses other than those listed above are incorrect and shall release the manufacturer from liability.

Preventing problems

- ▶ Do not make any alterations to the dryer, unless authorised to do so by Miele.
- ▶ Do not lean on the tumble dryer door. Otherwise, the tumble dryer may tip over, causing injury to yourself or others.
- ▶ Do not use a pressure washer or water jet to clean the tumble dryer.
- ▶ To ensure the correct performance of the tumble dryer and to prevent the risk of faults and fire, it is important to carry out maintenance on a regular basis.
- ▶ DO NOT USE OR STORE FLAMMABLE MATERIALS IN OR NEAR THIS APPLIANCE.
- ▶ Do not expose the dryer to air which contains chlorine, fluorine or other solvent vapours. This contaminated air can cause a fire.

Warning and Safety instructions

- ▶ To prevent the risk of fire, the following textiles must not be dried in the tumble dryer:
 - Items which have not been washed.
 - Items which have not been thoroughly cleaned and are still soiled with grease, oil or other deposits (such as kitchen linens or cosmetics cloths with cooking oils, grease, lotions, etc.). If items have not been thoroughly cleaned, there is a danger that they might ignite when heated, even after they have been removed from the tumble dryer at the end of the programme.
 - Oil-affected items can ignite spontaneously, especially when exposed to heat sources such as in a tumble dryer. The items become warm, causing an oxidation reaction in the oil. Oxidation creates heat. If the heat cannot escape, the items can become hot enough to catch fire. Piling, stacking or storing oil-affected items can prevent heat from escaping and so create a fire hazard. If it is unavoidable that fabrics contaminated with vegetable or cooking oil, or hair care products, are placed in a tumble dryer, they should first be washed in hot water with extra detergent - this will reduce, but not eliminate, the hazard.
 - Items (e.g. mops and floor cloths) that have been treated with inflammable cleaning agents or which contain residues of acetone, alcohol, benzene, petrol, kerosene, stain remover, turpentine, wax and wax remover or other chemicals.
 - Items such as foam rubber (latex foam), shower caps, waterproof textiles, rubber backed articles and clothes or pillows fitted with foam rubber pads should not be dried in the tumble dryer.
 - Items which have been splashed with hair lacquer, hair spray, nail varnish remover or similar substances.
- ▶ **Warning:** Never switch the tumble dryer off before the end of the drying programme unless all items are removed immediately and spread out to cool down.
- ▶ Never operate the tumble dryer without the fluff filter or with a damaged fluff filter. This could lead to malfunctions. Fluff can clog the air passages, heating elements and ducting, which could result in a fire. In this case, stop the tumble dryer immediately and replace the damaged fluff filter.

Technical safety

- ▶ Before installing the dryer, check it for visible signs of damage. Do not install or use a damaged appliance.
- ▶ Do not connect the dryer to the mains electricity supply by an extension lead. Extension leads do not guarantee the required safety of the appliance (e.g. danger of overheating).
- ▶ Fire hazard due to controllable socket. This tumble dryer must not be connected to a controllable socket (e.g. a timer). There is a risk of the laundry self-igniting if the tumble dryer's cooling phase is interrupted.
- ▶ The electrical safety of this appliance can only be guaranteed when continuity is complete between it and an effective earthing system. It is essential that this standard safety requirement is observed and regularly tested. If in any doubt, have the electrical installation inspected by a qualified electrician. Miele cannot be held liable for the consequences of an inadequate earthing system (e.g. electric shock).
- ▶ Unauthorised repairs could result in unforeseen dangers for the user, for which Miele cannot accept liability. Repairs must only be carried out by a Miele authorised service technician, otherwise any subsequent damage will not be covered by the warranty. Repair instructions can be requested from Miele.
- ▶ Faulty components must only be replaced by Miele original spare parts. Miele can only guarantee the safety standards of the machine when Miele replacement parts are used.

Warning and Safety instructions

► In the event of a fault, when replacing components and for cleaning and maintenance purposes, the tumble dryer must be disconnected from the power supply. The tumble dryer is only disconnected from the power supply if:

- it is switched off at the wall socket or the plug is withdrawn, or
- the circuit breakers are disconnected, or
- the circuit breakers have been completely removed

► This tumble dryer must not be installed and operated in mobile locations (e.g. on a ship).

► Please observe the instructions in "Installation" and "Technical data".

► The tumble dryer may only be operated when the ducting has been installed and the room is sufficiently ventilated.

► The ducting must never be installed in any of the following flues or shafts:

- Chimneys or exhaust smokestacks that are in use.
- Shafts that are used to ventilate installation rooms with fireplaces.
- Flues that are used by third parties.

If smoke or exhaust gas is pushed back into the flue or shaft, there is a risk of poisoning.

The appliance must not be discharged into a flue that is used for exhausting fumes from appliances burning gas or other fuels.

► Regularly check all components in the ducting (e.g. wall pipe, external grille, bends, elbows, etc.) to make sure that air can move through them and to ensure that they are working properly. Clean components when necessary. Fluff deposits in the ducting system will prevent the air from being extracted properly and, as a result, will stop the tumble dryer from working properly.

If existing ducting is due to be used, it must be checked before being installed in the tumble dryer.

Low pressure must not occur in the vent ducting.

► There is a risk of suffocation and poisoning due to exhaust gases being sucked back if gas-powered flow heaters, gas-powered room heaters, coal-burning stoves with a flue connection, etc., are installed in the same room, in the same flat or in neighbouring rooms and the negative pressure is 4 Pa or more.

You can prevent negative pressure in the installation room if you ensure sufficient room ventilation by taking the following measures (examples):

- Install vents that cannot be closed in the exterior walls.
- Use window switches so that the tumble dryer can only be switched on when a window is open.

Please always seek approval from the appropriate authority (e.g. gas installer) to confirm that the machine can be operated without risk and that a negative pressure of 4 Pa or more can be prevented.

► If multiple tumble dryers are to be connected to one exhaust air duct, a non-return flap must be installed directly on the duct for each tumble dryer.

Failure to do so may damage the dryers and affect their electrical safety.

► The electrical socket must be easily accessible so that the tumble dryer can be disconnected from the power supply at any time. The operator must be able to check from any access point that the plug is still removed.

► If the appliance is hard wired, adequate provision must be made on site to switch off all poles to disconnect the tumble dryer from the power supply. The means for disconnection must be incorporated in the fixed wiring in accordance with the wiring rules AS/NZS 3000.

► Do not block the gap between the bottom of the tumble dryer and the floor with plinth boards, deep pile carpet etc.

Warning and Safety instructions

- ▶ The appliance must not be installed behind a lockable door, a sliding door or a door with a hinge on the opposite side to that of the tumble dryer, in such a way that a full opening of the tumble dryer door is restricted.
- ▶ If the electrical connection cable is faulty, it must only be replaced by a Miele authorised service technician to protect the user from danger.



WARNING: FLAMMABLE MATERIAL

- ▶ Care is required to avoid causing a fire by igniting flammable material. Warning: Risk of fire/Flammable materials.
- ▶ In the event of a fault or when carrying out cleaning and maintenance, the on-site manual gas shut-off valve and the shut-off device on the gas meter must be closed.
- ▶ Before completing commissioning, maintenance, conversion and repair work, all gas-conducting components – from the manual shut-off valve to the burner jet – must be checked for leaks. Particular attention must be paid to the measurement connections on the gas valve and on the burner. Checks must be performed when the burner is both switched on and switched off.
- ▶ Carry out an annual visual inspection of the gas lines and gas appliances in your home. This inspection must comply with applicable national regulations.

Safety measures in the event that you smell gas

- Extinguish all flames immediately.
- Close the on-site gas shut-off device, the gas shut-off device on the gas meter or the main gas shut-off device immediately.
- Open all windows and doors immediately.
- Do not light any naked flames (e.g. matches or lighters).
- Do not smoke.
- If there is a smell of gas in a room, never enter it with a naked flame.
- Do not carry out any actions that will create electrical sparks (such as pulling out electrical plugs or pressing electrical switches or bells).
- If you cannot find the cause of the gas smell and all gas valves have been shut off, please call the gas utility company and emergency services immediately.

If other persons are being shown how to operate the appliance, they must be given and/or made aware of these important safety precautions.

Correct use

- ▶ Always close the drum door after each drying cycle. This way you will avoid the danger of
 - children climbing into the tumble dryer or hiding things in it.
 - pets or other small animals climbing into the tumble dryer.
- ▶ Keep the room where the tumble dryer is located free from dust and fluff. If the air that is taken into the machine contains dirt particles, they can cause blockages. This can lead to faults and create a fire hazard. Fluff must not be allowed to accumulate around the tumble dryer.
- ▶ Never operate the tumble dryer without the fluff filter or with a damaged fluff filter. This could lead to malfunctions. Fluff can clog the air passages, heating elements and ducting, which could result in a fire. In this case, stop the tumble dryer immediately and replace the damaged fluff filter.
- ▶ The fluff filter must be cleaned on a regular basis.

Warning and Safety instructions

- ▶ To ensure problem-free operation of the tumble dryer:
 - Clean the surface of the fluff filter after each drying cycle.
 - In addition, the fluff filter and the air passages must be cleaned when prompted by the display.
- ▶ Remove all items from the pockets of the laundry to be dried (e.g. lighters, matches, keys).
- ▶ Many programmes are followed by the cooling phase to ensure that the items of laundry are kept at a temperature that will not cause them damage (for instance, to prevent the risk of the laundry self-igniting). Always remove all items of laundry from the tumble dryer immediately after the cooling phase.
- ▶ Fabric softener and similar products must be used according to the instructions on the manufacturer's packaging.
- ▶ For appliance parts made from stainless steel:
Avoid contact between stainless steel surfaces and liquid detergents or disinfecting agents containing chlorine or sodium hypochlorite. These agents can cause corrosion on stainless steel.
Aggressive chlorine bleach vapours can also be corrosive.
Do not store open containers of these agents near the appliance.

Accessories

- ▶ Only use genuine Miele spare parts and accessories with this machine. Using spare parts or accessories from other manufacturers will invalidate the warranty, and Miele cannot accept liability.

 Miele cannot be held liable for damage caused by non-compliance with these Warning and Safety instructions.

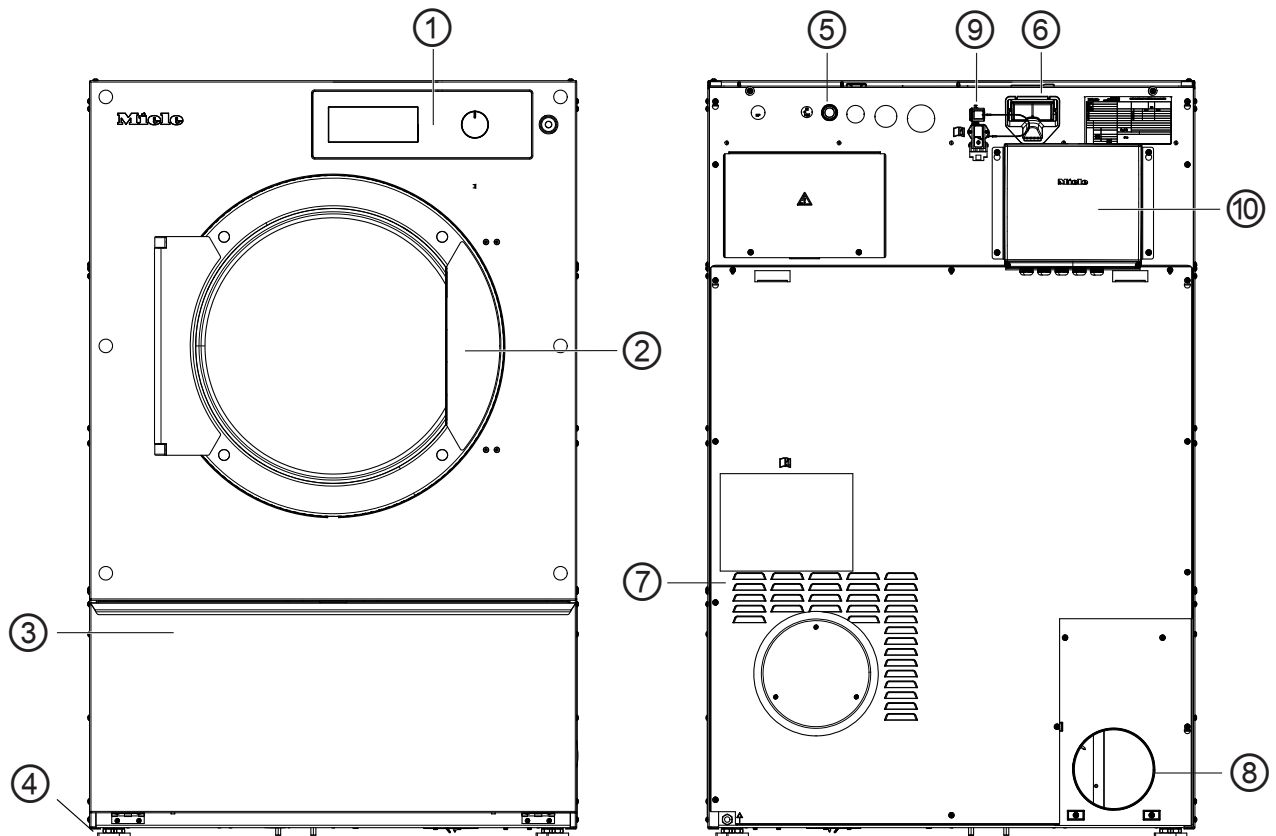





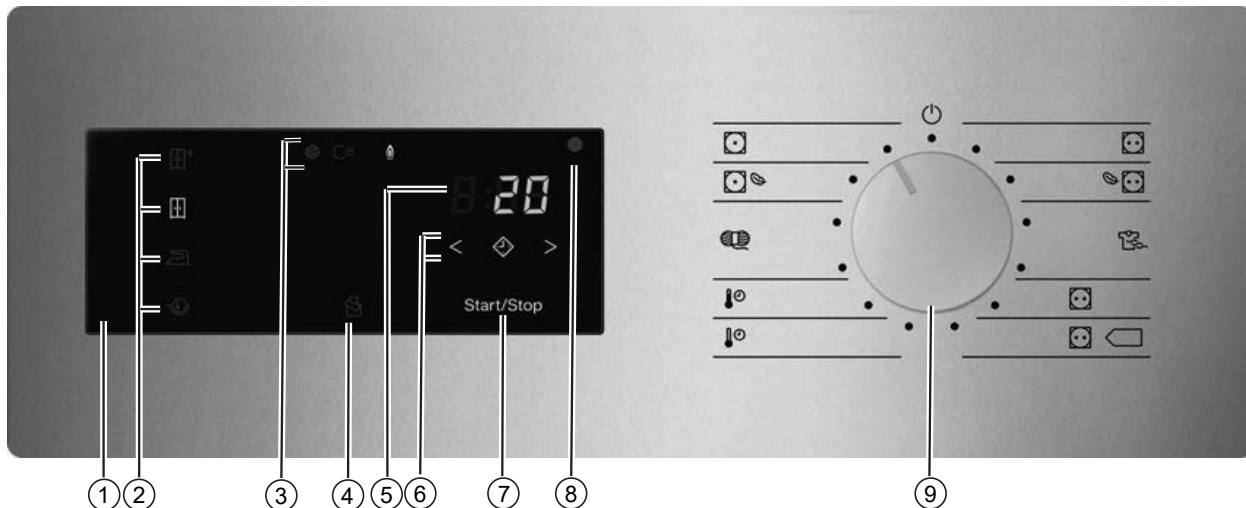

- ① Control panel with rotary control
- ② Door
- ③ Fluff filter flap
- ④ 4 height-adjustable screw feet
- ⑤ Electrical connection
- ⑥ Communication module slot
- ⑦ Intake vents for drying air
- ⑧ Exhaust connection
- ⑨ Connection for communication box
- ⑩ Communication box (optional):
For setting up a connection with external systems





Operating the tumble dryer

Machines with residual moisture control (ROP)















- ① **Control panel**
- ② **Sensors for the drying levels**
- ③  **status indicators**
Light up when necessary.
- ④  **sensor control**
Activates the Intermittent fan operation to perfectly dry light fabrics, e.g. bed linen and cloths.
- ⑤ **8:88 time display**
Displays messages or the remaining programme running time in hours and minutes.
- ⑥ **<  > sensors**
For time selection. After touching the  sensor, a later start time for the programme (Delay start) can be selected. The  sensor lights up brightly when selected. The duration of the Delay start period is selected by touching the < or > sensor.
- ⑦ **Start/Stop sensor control**
For starting the selected drying programme or cancelling a programme that has already started. The programme selected can be started as soon as the sensor control starts pulsating.
- ⑧ **Optical interface**
Used for data transfer by Miele Professional Service.
- ⑨ **Programme selector**
For selecting programmes and for switching the machine off. The tumble dryer is switched on when you select a programme and switched off by turning the programme selector to the  position.

Drying levels

- + sensor = “Normal plus” drying level
-  sensor = “Normal” drying level
-  sensor = “Hand iron” drying level
-  sensor = “Machine iron” drying level

Drying programmes

-  position = “Cottons” programme
For drying cotton and linen .
-  position = “Cottons Low temperature” programme
For drying delicate cotton and linen fabrics.
-  position = “Synthetics/Delicates” programme
For drying synthetic fibres and artificial silk to 20% residual moisture.
-  PRO position = “Label programme” programme
-   position = “Label programme” programme
-  position = “Time drying cool air” programme
For airing fabrics with 10 minutes of drying time.
-  position = “Timed drying warm air” programme
For drying fabrics at high temperatures and with 20 minutes of drying time.
-  position = “Woollens” programme
For drying woollens with 5 minutes of drying time.
-  position = “Minimum iron Low temperature” programme
-  position = “Minimum iron” programme
-  position = Machine off

Operating the tumble dryer

Machines with time control (TOP)

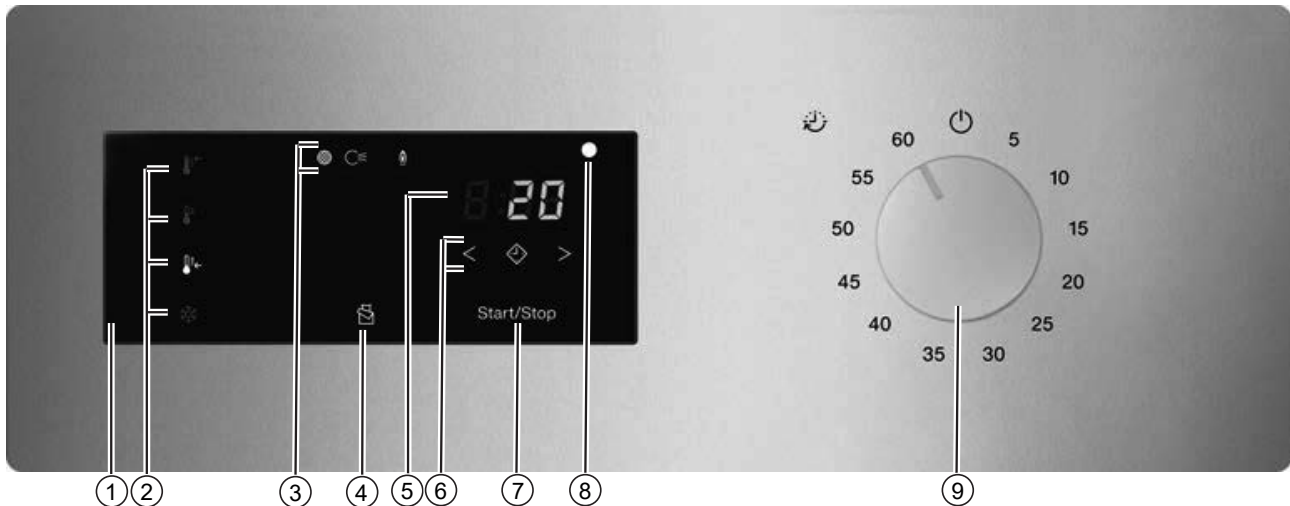

① **Control panel**

② **Sensors for the drying levels**

③ **status indicators**
Light up when necessary.

④ **sensor control**

Activates the Intermittent fan operation to perfectly dry light fabrics, e.g. bed linen and cloths.

⑤ **8:88 time display**

Displays messages or the remaining programme running time in hours and minutes.

⑥ **sensors**

For time selection. After touching the sensor, a later start time for the programme (Delay start) can be selected. The sensor lights up brightly when selected. The duration of the Delay start period is selected by touching the or sensor.

⑦ **Start/Stop sensor control**

For starting the selected drying programme or cancelling a programme that has already started. The programme selected can be started as soon as the sensor control starts pulsating.





⑧ **Optical interface**

Used for data transfer by Miele Professional Service.

⑨ **Time selector**

For selecting times and for switching the machine off. The tumble dryer is switched on when you select a time and switched off based on the position of the time selector

Drying levels (TOP)

-  sensor = “High” temperature setting
-  sensor = “Medium” temperature setting
-  sensor = “Low” temperature setting
-  sensor = “Cool” temperature setting
- 5 position = Timed drying: 05 minutes
- 10–55 position = Timed drying: 10–55 minutes
- 60 position = Timed drying: 60 minutes
-  position = Machine off

Operating the tumble dryer

Machines with payment systems (COP)

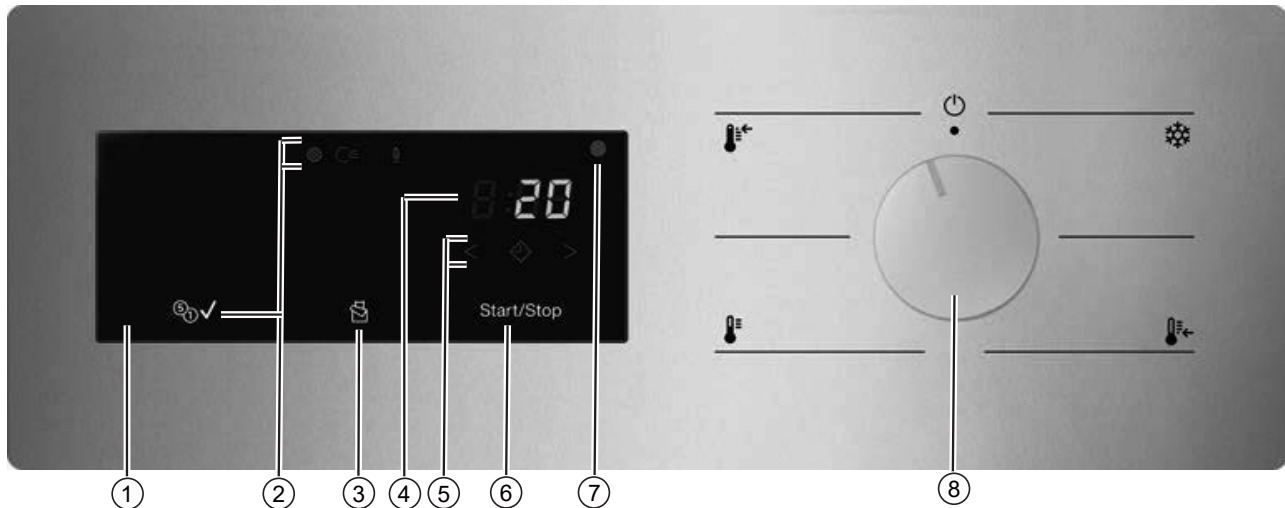

① **Control panel**

②  **status indicators**
Light up when necessary.



③  **sensor control**

Activates the Intermittent fan operation to perfectly dry light fabrics, e.g. bed linen and cloths.

④ **8:88 time display**

Displays messages or the remaining programme running time in hours and minutes.

⑤  **sensors**

For time selection. After touching the  sensor, a later start time for the programme (Delay start) can be selected. The  sensor lights up brightly when selected. The duration of the Delay start period is selected by touching the < or > sensor.

⑥ **Start/Stop sensor control**

For starting the selected drying programme or cancelling a programme that has already started. The programme selected can be started as soon as the sensor control starts pulsating.

⑦ **Optical interface**

Used for data transfer by Miele Professional Service.

⑧ **Temperature setting selector**

For selecting temperature settings and for switching the machine off. The tumble dryer is switched on when you select a temperature setting and switched off based on the position of the temperature setting selector .

Drying programmes

- ❄️ position range = “Cool” temperature setting
For airing fabrics.
- 🌡️ position range = “Low” temperature setting
For drying delicates made from artificial silk or synthetic fibres.
- 🌡️ position range = “Medium” temperature setting
For drying easy-care synthetics and mixed fibres.
- 🌡️ position range = “High” temperature setting
For drying cotton and linen fabrics.
- ⏻ position = Machine off

Operating the tumble dryer

How the control panel works

The sensors react to fingertip contact. Selection is possible as long as the respective sensor is illuminated.





If a sensor is brightly lit, this means it is currently selected.

If a sensor is dimly lit, this means it can be selected.





Sensors for the drying levels

After selecting a drying level programme with the programme selector, the recommended drying level lights up. Drying levels that can be selected are dimly lit.





Drying levels

-  sensor = "Normal plus" drying level
-  sensor = "Normal" drying level
-  sensor = "Hand iron" drying level
-  sensor = "Machine iron" drying level





Drying levels (TOP)

-  sensor = "High" temperature setting
-  sensor = "Medium" temperature setting
-  sensor = "Low" temperature setting
-  sensor = "Cool" temperature setting













Drying levels in payment system operation

-  sensor = "High" temperature setting
-  sensor = "Medium" temperature setting
-  sensor = "Low" temperature setting
-  sensor = "Cool" temperature setting

Indicators

-  indicator light: lights up when the fluff filter needs to be cleaned.
-  indicator light: lights up if a fault is present in the ducting.
-  indicator light (gas-heated machines only): lights up when the heating is active.
-  indicator light (machines with payment system only): lights up when payment has been made.
- Time display **8:88**: displays messages or the remaining programme running time in hours and minutes. With most drying programmes, the duration displayed may vary or "jump". The following factors, among others, affect the programme duration displayed: the quantity of laundry, the type of fabric and the residual moisture in the laundry. The electronic module will continually assess the conditions and adjust the programme duration with increasing accuracy.

Overview of messages in the time display

-  = Programme change not possible. Displayed when the programme selector is turned to another drying programme while the drying programme is running.
-  (rotating) =
 - The drying programme has been started and will begin in a few seconds.
 - The external exhaust valve is opened while the drying programme is running.
 - The laundry is cooled down after tumble drying.
-  = Drying programme stopped after interruption of energy supply. The drying programme that was originally started was interrupted before the end of the programme (e.g. by switching off the tumble dryer). The drying programme can be resumed by touching the pulsating sensor control Start/Stop.
-  (key) = Drying programme locked
-  = Set up Wi-Fi or local access point.
-  = Set up Wi-Fi via soft AP (= software access point).
-  = Set up Wi-Fi via WPS.
-  = Connection successfully established
-  = Connection not successful
-  = Update available
-  = Peak load active (only if electrically heated tumble dryers are connected to an energy management system)
-  (only for operation with optional payment device) = prompts for payment or additional payment if the paid time has expired.

Using for the first time

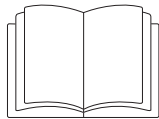

⚠ Risk of injury or damage to property due to improper installation. Incorrect installation of the tumble dryer can lead to personal injury or damage to property.
Before commissioning the tumble dryer for the first time, make sure it has been installed correctly.
Connect the tumble dryer correctly.
Please observe the instructions in “Installation”.

Complete the initial commissioning process. During the initial commissioning process, you will need to define the settings for daily use of the tumble dryer. Some settings can only be modified during the initial commissioning process. After that, they can only be changed by Miele Professional Service.

1. Notes on correct laundry care

Washing before drying

Heavily soiled laundry must be washed particularly thoroughly. Use sufficient detergent and select a high wash temperature. If in doubt, wash the items several times.

The tumble dryer must not be used for drying items of laundry which have been cleaned using industrial chemicals.

New and coloured items must be washed thoroughly and separately. Do not dry new and coloured items with light coloured garments. There is the risk of colours running and discolouring other garments or even plastic components in the tumble dryer. Dark coloured fluff can also settle on light coloured garments and vice versa.

Removing foreign objects

Before drying, ensure that there are no foreign objects in the laundry.

 Damage due to foreign objects which were not removed from the laundry.

Foreign objects in the laundry can melt, burn, or explode.







Ensure that any foreign objects (e.g. detergent dispensing balls, lighters, etc.) have been removed from the laundry.

Check seams and stitching to ensure that padding and linings are intact. This way you can prevent fillings from falling out, which could create a fire hazard. Sew in or remove loosened underwiring from bras.

 Risk of fire due to incorrect use and operation.

The laundry can burn and destroy the dryer and the surroundings. See “Warnings and safety instructions” for further information.

Care symbols

Drying	
	Normal/Higher temperature
	Low temperature*
* Select Low temperature.	
	Do not tumble dry
Ironing	
	Very hot
	Hot
	Warm
	Do not iron

2. Loading the tumble dryer

Loading the laundry

 Damage to fabrics caused by incorrect laundry care. Incorrect laundry care can damage fabrics during tumble drying. Before loading, read chapter “1. Notes on correct laundry care” first.

Drying

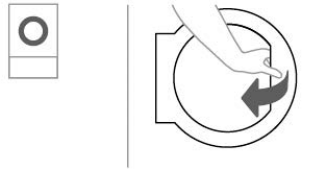

- Open the door.

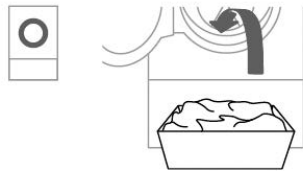

- Load the laundry.

Do not overload the drum.
Overloading can cause unnecessary wear and tear to the laundry and give a disappointing drying result. It can also cause more creasing.

Closing the door

⚠ Damage caused by laundry getting trapped.
Laundry can be damaged by getting trapped when closing the door. When closing the door, make sure that laundry does not get trapped in the door opening.

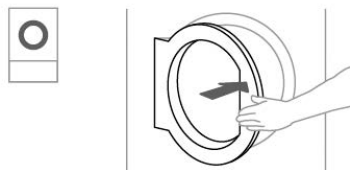

- Close the door gently.

3. Selecting a programme

Selecting a programme

The tumble dryer is switched on by selecting a programme and switched off by turning the programme selector to the  position.

- Turn the programme selector to the required programme.

A drying level may light up and durations will appear in the time display.

“Bedding” optional function

To activate the “Bedding” function, touch the  sensor control.

This function activates intermittent fan operation and prevents lightweight items of laundry (bed sheets or thin fabrics like microfibre cloths) from sticking to the drum perforations due to the air flow pressure. The “Bedding” function thus ensures lightweight items are dried evenly and protected against possible creases inside the tumble dryer.

Drying level for programmes with a selectable drying level

The preset drying level can be changed if required.

- Touch the sensor for the drying level you want. It will light up brightly.

The drying levels that are available for selection depend on the selected programme.

Timed drying programmes and other programmes

Warm air

You can set the duration in one-minute increments from 0:20 minutes to 2:00 hours.

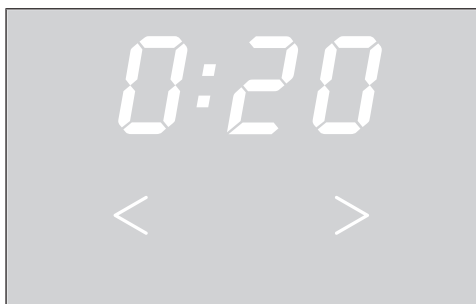



- Touch the < or > sensor repeatedly until the required programme duration appears in the time display.

The drying level is preset by the dryer and cannot be altered.

Selecting Delay start

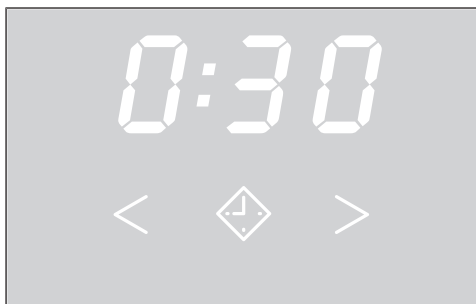
With Delay start you can delay the start of a programme from 0:30 minutes up to 24h (hours).



- Touch the  sensor.
 -  will light up brightly.
 - Touch the > or < sensor repeatedly until the required Delay start time appears in the time display.
- Useful tip:** The time will count upwards and downwards automatically if you touch the > or < sensor continuously.

Altering Delay start

- Touch the *Start/Stop* sensor.
- Touch the > or < sensor repeatedly until the required Delay start time appears in the time display.
- Touch the *Start/Stop* sensor.

The Delay start function continues to count down.

Drying

Cancelling/
Deleting Delay
start

- Turn the programme selector to the  position. Alternatively, you can also cancel Delay start by opening the door.

Delay start
countdown

- Delay start times of more than 10h will count down in hours and then in minutes until the start of the programme.
- The drum will rotate briefly every hour until the start of the programme to reduce laundry creasing (Anti-crease function).

4. Starting a programme

Starting a
programme

- Touch the flashing *Start/Stop* sensor.

The *Start/Stop* sensor lights up.

Programme sequence

- If Delay Start has been selected, the Delay Start period will start to count down first.
- With a longer Delay start time, the drum will rotate occasionally. This will loosen up the laundry.
- The programme starts.

Programme
running time/Time
left estimation

The programme running time depends on the quantity of laundry, the type of fabric and the residual moisture in the laundry. The displayed programme running time for drying level programmes can therefore vary or “jump”. The tumble dryer’s electronic module adapts during the ongoing drying programme. The displayed programme running time becomes more and more accurate.

When using the programmes for the first time, the displayed time sometimes deviates significantly from the real time left. The difference between the estimated and achieved time becomes smaller if the corresponding programme is run more often. If different load sizes are dried in one programme, the time left display can only show an approximate time.

Laundry items and fabrics can wear out unnecessarily.
Avoid overdrying laundry and garments.

Energy saving

After a programmed time, the indicators dim. The *Start/Stop* sensor flashes slowly.

- Touch the *Start/Stop* sensor to switch the indicators back on. Energy saving for the indicators will not affect a running programme.
- Before the programme finishes, the laundry is cooled.

5. End of the programme – unloading the drum

At the end of the programme

The laundry is cooled down shortly before the end of the programme. The laundry can then be removed.

The programme has ended when only 0:00 is shown in the display.

If *Anti-crease* has been selected (see "Programmable functions"), the drum will rotate in intervals. This reduces creasing if the laundry cannot be removed straight away.

The tumble dryer will switch off automatically after the programmed time after the end of a programme.

Removing the laundry

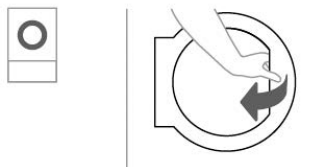

- Open the door.

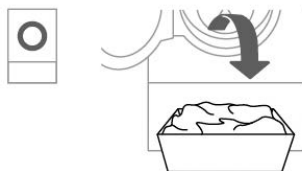

- Remove all of the laundry from the drum.

⚠ Damage caused by overdrying.
Laundry left in the dryer can be damaged by overdrying.
Always remove all items from the drum once drying has finished.

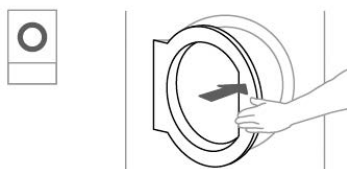

- Close the door.
- Switch the tumble dryer off.

Care notes

This tumble dryer requires regular maintenance, particularly if it is used on a continuous basis. See "Cleaning and care".

Changing the programme sequence

Changing a programme after it has started

You cannot change to another programme once a programme has started (this prevents unintentional alterations). You will need to cancel the current programme before you can select a new one.

 Risk of fire due to incorrect use and operation.
The laundry can burn and destroy the dryer and the surroundings.
See “Warning and Safety instructions” for further information.

If you turn the programme selector while the drying programme is running, **-0-** appears in the time display. **-0-** disappears when you turn the programme selector back to the original programme.

Cancelling the current programme

- Touch the *Start/Stop* sensor for more than 2 seconds.

The items will be cooled down, depending on the temperature reached and how long they have been dried for.

0:00 will light up if you press the *Start/Stop* sensor again during the cooling phase.

- Open the door.
- Close the door.
- Select a different programme from the main menu.
- Touch the *Start/Stop* sensor.

Selecting another programme

Adding or removing laundry

- Open the door.

 Risk of burning when touching hot laundry in the drum.
You could burn yourself.
Let the laundry cool down and remove it carefully.

- Add or remove laundry.
- Close the door.
- Start the programme.

Adding laundry during the Delay start period

You can open the door to add or remove laundry.

- All programme settings will be saved.
- You can change the drying level, if required.

- Open the door.
- Add or remove laundry.
- Close the door.
- Touch the *Start/Stop* sensor so that the Delay start period continues.

Time left

Altering the programme sequence can cause the programme duration shown in the display to be adjusted.

Supervisor level (programming mode)

Requirements for accessing supervisor level

- The appliance is switched on.
- The appliance door is open.

Accessing supervisor level

- Touch and hold the *Start/Stop* sensor control and close the door.

The *Start/Stop* sensor control flashes rapidly for 2 seconds.

- Continue touching the *Start/Stop* sensor control for at least 4 seconds.

The *Start/Stop* sensor control will light up constantly. This indicates that you have successfully accessed the supervisor level programming mode.

- Release the *Start/Stop* sensor control.

If the illuminated *Start/Stop* sensor control is not released again within 6 seconds, the appliance will detect an accessing error or a door jam.

The maximum time for the access attempt is 10 seconds. The attempt will then be cancelled automatically.

Overview of supervisor level

If the preset values in the supervisor level are changed, the tumble dryer's energy requirements may change.

Program me	Designation	Possible set value	Default setting	Explanation
P01	Drying level Cottons	01 02 03 04 05 06 07	04	01 = Damper 3 02 = Damper 2 03 = Damper 1 04 = Standard 05 = Drier 1 06 = Drier 2 07 = Drier 3
P02	Drying level Minimum iron	01 02 03 04 05 06 07	04	01 = Damper 3 02 = Damper 2 03 = Damper 1 04 = Standard 05 = Drier 1 06 = Drier 2 07 = Drier 3
P03	Cottons & Timed operation internal/ external 1 Heater bank temperature	01–20	20	See “Heater bank temperature” table
P04	Cottons & Timed operation internal/ external 1 Process air temperature	00–46	46	See “Process air temperature” table
P05	Cottons & Timed operation internal/ external 1 Drum drive running time in primary direction	01–51	35	See “Reversing cycle” table
P06	Cottons & Timed operation internal/ external 1 Drum drive running time in reverse direction	01–51	35	See “Reversing cycle” table

Supervisor level (programming mode)

Program me	Designation	Possible set value	Default setting	Explanation
P07	Cottons & Timed operation internal/ external 1 Drum drive pause	01–14	01	See “Pauses” table
P08	Cottons & Timed operation internal/ external 2 Heater bank temperature	01–20	10	See “Heater bank temperature” table
P09	Cottons & Timed operation internal/ external 2 Process air temperature	00–46	31	See “Process air temperature” table
P10	Cottons & Timed operation internal/ external 2 Drive running time in primary direction	01–51	35	See “Reversing cycle” table
P11	Cottons & Timed operation internal/ external 2 Drive running time in reverse direction	01–51	35	See “Reversing cycle” table
P12	Cottons & Timed operation internal/ external 2 Drive pause time	01–14	01	See “Pauses” table
P13	Synthetics/Delicates & Timed operation internal/external 3 Heater bank temperature	01–20	04	See “Heater bank temperature” table
P14	Synthetics/Delicates & Timed operation internal/external 3 Process air temperature	00–46	11	See “Process air temperature” table
P15	Synthetics/Delicates & Timed operation internal/external 3 Drive running time in primary direction	01–51	05 TOP/COP: 35	See “Reversing cycle” table
P16	Synthetics/Delicates & Timed operation internal/external 3 Drive running time in reverse direction	01–51	05 TOP/COP: 35	See “Reversing cycle” table
P17	Synthetics/Delicates & Timed operation internal/external 3 Drive pause time	01–14	01	See “Pauses” table
P18	PRO & Timed operation internal/ external 4 Heater bank temperature	01–20	20 TOP/COP: 00	See “Heater bank temperature” table
P19	PRO & Timed operation internal/ external 4 Process air temperature	00–46	46 TOP/COP: 00	See “Process air temperature” table
P20	PRO & Timed operation internal/ external 4 Drive running time in primary direction	01–51	35	See “Reversing cycle” table
P21	PRO & Timed operation internal/ external 4 Drive running time in reverse direction	01–51	35	See “Reversing cycle” table
P22	PRO & Timed operation internal/ external 4 Drive pause time	01–14	01	See “Pauses” table
P23	Label Heater bank temperature	01–20	20	See “Heater bank temperature” table
P24	Label Process air temperature	00–46	46	See “Process air temperature” table

Supervisor level (programming mode)

Program me	Designation	Possible set value	Default setting	Explanation
P25	Label Drum drive primary direction	01–51	35	See “Reversing cycle” table
P26	Label Drum drive reverse direction	01–51	35	See “Reversing cycle” table
P27	Label Drum drive pause	01–14	01	See “Pauses” table
P28	Timed drying cool air Drum drive primary direction	01–51	35	See “Reversing cycle” table
P29	Timed drying cool air Drum drive reverse direction	01–51	35	See “Reversing cycle” table
P30	Timed drying cool air Drum drive pause	01–14	01	See “Pauses” table
P31	Timed drying warm air Heater bank temperature	01–20	20	See “Heater bank temperature” table
P32	Timed drying warm air Process air temperature	00–46	46	See “Process air temperature” table
P33	Timed drying warm air Drum drive primary direction	01–51	35	See “Reversing cycle” table
P34	Timed drying warm air Drum drive reverse direction	01–51	35	See “Reversing cycle” table
P35	Timed drying warm air Drum drive pause	01–14	01	See “Pauses” table
P36	Woollens Heater bank temperature	01–20	20	See “Heater bank temperature” table
P37	Woollens Process air temperature	00–46	46	See “Process air temperature” table
P38	Woollens Drive running time in primary direction	01–51	21	See “Reversing cycle” table
P39	Woollens Drive running time in reverse direction	01–51	01	See “Reversing cycle” table
P40	Woollens Drive pause time	01–14	09	See “Pauses” table
P41	Minimum iron Low temperature Heater bank temperature	01–20	04	See “Heater bank temperature” table
P42	Minimum iron Low temperature Process air temperature	00–46	11	See “Process air temperature” table
P43	Minimum iron Low temperature Drive running time in primary direction	01–51	35	See “Reversing cycle” table
P44	Minimum iron Low temperature Drive running time in reverse direction	01–51	35	See “Reversing cycle” table
P45	Minimum iron Low temperature Drive pause time	01–14	01	See “Pauses” table
P46	Minimum iron Heater bank temperature	01–20	10	See “Heater bank temperature” table
P47	Minimum iron Process air temperature	00–46	31	See “Process air temperature” table

Supervisor level (programming mode)

Program me	Designation	Possible set value	Default setting	Explanation
P48	Minimum iron Drive running time in primary direction	01–51	35	See “Reversing cycle” table
P49	Minimum iron Drive running time in reverse direction	01–51	35	See “Reversing cycle” table
P50	Minimum iron Drive pause time	01–14	01	See “Pauses” table
P51	Fan pulsed operation off/on	00 01	00	00 = Off 01 = On
P52	Fan pulsed operation: Time after start without intermittent fan operation	01–99	30	See table “Fan pulsed operation after start”
P54	Fan pulsed operation Number of reversing cycles until the next time the fan operates intermittently	01–99	02	01 = 1 cycle 02 = 2 cycles xx = xx cycles
P55	Finish tone	00 01 02	01	00 = Off 01 = Normal 02 = Loud
P56	Keypad tone	00 01 02	01	00 = Off 01 = Normal 02 = Loud
P57	Welcome tone	00 01 02	01	00 = Off 01 = Normal 02 = Loud
P58	Fault alarm	00 01	01	00 = Off 01 = On
P59	Backlight brightness	01 02 03 04 05 06 07	07	Brightness of the selected backlight
P60	Backlight brightness dimmed	01 02 03 04 05 06 07	02	01 = 10% of maximum brightness 02 = 20% of maximum brightness 03 = 30% of maximum brightness 04 = 40% of maximum brightness 05 = 50% of maximum brightness 06 = 60% of maximum brightness 07 = 70% of maximum brightness

Supervisor level (programming mode)

Program me	Designation	Possible set value	Default setting	Explanation
P61	Display brightness	01 02 03 04 05 06 07 08 09 10 11 12 13 14 15	08	Seven-segment display brightness
P62	“Display” off status	00 01 02 03 04	02	00 = Off 01 = On after 10 minutes, not during programme in operation 02 = On after 10 minutes 03 = On after 30 minutes, not during programme in operation 04 = On after 30 minutes
P63	“Machine” off status	00 01 02 03	01	00 = No switch-off 01 = After 15 minutes 02 = After 20 minutes 03 = After 30 minutes
P65	Further cooling	00 01	01	00 = Off 01 = On
P66	Cooling down temperature	00–15	15	00 = 40 °C/104 °F 01 = 41 °C/106 °F 02 = 42 °C/108 °F 03 = 43 °C/109 °F 04 = 44 °C/111 °F 05 = 45 °C/113 °F 06 = 46 °C/115 °F 07 = 47 °C/117 °F 08 = 48 °C/118 °F 09 = 49 °C/120 °F 10 = 50 °C/122 °F 11 = 51 °C/124 °F 12 = 52 °C/126 °F 13 = 53 °C/127 °F 14 = 54 °C/129 °F 15 = 55 °C/131 °F
P67	Memory	00 01	00	00 = Off 01 = On

Supervisor level (programming mode)

Program me	Designation	Possible set value	Default setting	Explanation
P68	Anti-crease	00 01 02 03 04 05 06 07 08 09 10 11 12	02	00 = Off 01 = 1 h 02 = 2 h 03 = 3 h 04 = 4 h 05 = 5 h 06 = 6 h 07 = 7 h 08 = 8 h 09 = 9 h 10 = 10 h 11 = 11 h 12 = 12 h
P70	Clean the filters	00–55	55	00 = Off xx = xx h 55 = 55 h
P71	Delay start	00 01	00	00 = Off 01 = On
P74	Door opening status	00 01	00	00 = Off = programme cancelled when door is opened 01 = On = programme interrupted when door is opened
P85	Pressure sensor (external)	00 01 02	00	00 = Off 01 = Normally open contact 02 = Normally closed contact
P86	External exhaust flap	00 01	00	00 = No 01 = Yes
P87	External exhaust flap delay	00–99	00	00 = None 01 = 1 s 02 = 2 s 99 = 99 s
P88	Additional fan	00 01	00	00 = Off 01 = On
P91	COM module selection	00 01 02	00	00 = Off 01 = Internal module 02 = External module
P92	External prog. lock	00 01	01	00 = Off 01 = On

Heater bank temperature

Set value in the display	Temperature
01	55 °C/131 °F
02	60 °C/140 °F
03	65 °C/149 °F
04	70 °C/158 °F
05	75 °C/167 °F
06	80 °C/176 °F
07	85 °C/185 °F

Supervisor level (programming mode)

Set value in the display	Temperature
08	90 °C/194 °F
09	95 °C/203 °F
10	100 °C/212 °F
11	105 °C/221 °F
12	110 °C/230 °F
13	115 °C/239 °F
14	120 °C/248 °F
15	125 °C/257 °F
16	130 °C/266 °F
17	135 °C/275 °F
18	140 °C/284 °F
19	145 °C/293 °F
20	150 °C/302 °F

Process air temperature

Set value in the display	Temperature
00	Cold
01	30 °C/86 °F
02	31 °C/88 °F
03	32 °C/90 °F
04	33 °C/91 °F
05	34 °C/93 °F
06	35 °C/95 °F
07	36 °C/97 °F
08	37 °C/99 °F
09	38 °C/100 °F
10	39 °C/102 °F
11	40 °C/104 °F
12	41 °C/106 °F
13	42 °C/108 °F
14	43 °C/109 °F
15	44 °C/111 °F
16	45 °C/113 °F
17	46 °C/115 °F
18	47 °C/117 °F
19	48 °C/118 °F
20	49 °C/120 °F
21	50 °C/122 °F
22	51 °C/124 °F
23	52 °C/126 °F
24	53 °C/127 °F
25	54 °C/129 °F
26	55 °C/131 °F
27	56 °C/133 °F

Supervisor level (programming mode)

Set value in the display	Temperature
28	57 °C/135 °F
29	58 °C/136 °F
30	59 °C/138 °F
31	60 °C/140 °F
32	61 °C/142 °F
33	62 °C/144 °F
34	63 °C/145 °F
35	64 °C/147 °F
36	65 °C/149 °F
37	66 °C/151 °F
38	67 °C/153 °F
39	68 °C/154 °F
40	69 °C/156 °F
41	70 °C/158 °F
42	71 °C/160 °F
43	72 °C/162 °F
44	73 °C/163 °F
45	74 °C/165 °F
46	75 °C/167 °F

Reversing cycle

Set value in the display	Seconds
01	20 s
02	22 s
03	24 s
04	26 s
05	28 s
06	30 s
07	32 s
08	34 s
09	36 s
10	38 s
11	40 s
12	42 s
13	44 s
14	46 s
15	48 s
16	50 s
17	52 s
18	54 s
19	56 s
20	58 s
21	60 s
22	62 s

Supervisor level (programming mode)

Set value in the display	Seconds
23	64 s
24	66 s
25	68 s
26	70 s
27	72 s
28	74 s
29	76 s
30	78 s
31	80 s
32	82 s
33	84 s
34	86 s
35	88 s
36	90 s
37	92 s
38	94 s
39	96 s
40	98 s
41	100 s
42	102 s
43	104 s
44	106 s
45	108 s
46	110 s
47	112 s
48	114 s
49	116 s
50	118 s
51	120 s

Supervisor level (programming mode)

Pauses

Set value in the display	Seconds
01	2 s
02	3 s
03	4 s
04	5 s
05	6 s
06	7 s
07	8 s
08	9 s
09	10 s
10	11 s
11	12 s
12	13 s
13	14 s
14	15 s

Fan pulsed operation after start

Set value in the display	Seconds
01	30 s
02	60 s
03	90 s
04	120 s
05	150 s
06	180 s
07	210 s
08	240 s
09	270 s
10	300 s
11	330 s
12	360 s
13	390 s
14	420 s
15	450 s
16	480 s
17	510 s
18	540 s
19	570 s
20	600 s
21	630 s
22	660 s
23	690 s
24	720 s
25	750 s
26	780 s

Supervisor level (programming mode)

Set value in the display	Seconds
27	810 s
28	840 s
29	870 s
30	900 s
31	930 s
32	960 s
33	990 s
34	1020 s
35	1050 s
36	1080 s
37	1110 s
38	1140 s
39	1170 s
40	1200 s
41	1230 s
42	1260 s
43	1290 s
44	1320 s
45	1350 s
46	1380 s
47	1410 s
48	1440 s
49	1470 s
50	1500 s
51	1530 s
52	1560 s
53	1590 s
54	1620 s
55	1650 s
56	1680 s
57	1710 s
58	1740 s
59	1770 s
60	1800 s
61	1830 s
62	1860 s
63	1890 s
64	1920 s
65	1950 s
66	1980 s
67	2010 s
68	2040 s
69	2070 s
70	2100 s

Supervisor level (programming mode)

Set value in the display	Seconds
71	2130 s
72	2160 s
73	2190 s
74	2220 s
75	2250 s
76	2280 s
77	2310 s
78	2340 s
79	2370 s
80	2400 s
81	2430 s
82	2460 s
83	2490 s
84	2520 s
85	2550 s
86	2580 s
87	2610 s
88	2640 s
89	2670 s
90	2700 s
91	2730 s
92	2760 s
93	2790 s
94	2820 s
95	2850 s
96	2880 s
97	2910 s
98	2940 s
99	2970 s

Quitting programming mode

- To quit programming mode, turn the rotary control on the tumble dryer to the  position. The tumble dryer is switched off.

Cleaning the fluff filter

⚠ Risk of fire if the tumble dryer is operated without a fluff filter.

If there is no fluff filter, the air channels, heating elements and vent ducting can become clogged during drying and may catch fire.

The fluff filter must not be removed for cleaning.

Never use the tumble dryer without the fluff filter in place.

Always replace a damaged fluff filter immediately.

The fluff filter catches any fluff that accumulates and must be cleaned at least once per working day, as well as when the corresponding prompt appears in the display.

To reset the display prompt for cleaning the filter, the fluff filter flap must remain open for at least 10 seconds. In the event of a heavy build-up of fluff, the fluff filter should be cleaned several times per day.

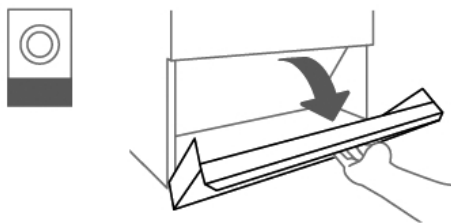

- Open the fluff filter flap.

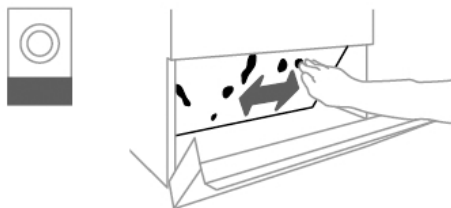

- Remove the fluff from the fluff filter using your hands.

Do not use pointed or sharp-edged objects to clean the fluff filter.
They can damage the fluff filter.

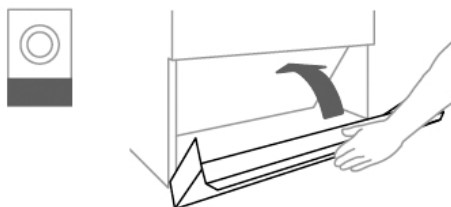

- Close the fluff filter flap after cleaning the fluff filter.

Cleaning and care

Cleaning the drum and the outside of the casing

⚠ Risk of death due to electric shock.

The tumble dryer must be completely disconnected from the power supply before performing cleaning or maintenance work.

Before starting cleaning or maintenance work, always switch off the tumble dryer at the main switch (on site).

Do not use a pressure washer or water jet to clean the tumble dryer.

⚠ Risk of damage due to solvent-based cleaning agents and abrasive cleaners.

Solvent-based cleaning agents, abrasive cleaners, glass cleaners or all-purpose cleaners can cause damage to plastic surfaces and other parts.

Clean the tumble dryer with a slightly damp cloth and a mild non-abrasive cleaning agent or soapy water.

- Clean the seal around the inside of the door with a damp cloth.
- The tumble dryer drum must be wiped clean with a soft, damp cloth after drying items that have been starched.
- Dry all parts with a soft cloth.
- The drum and other stainless steel parts can be cleaned with a suitable stainless steel cleaner if you wish.

The air intake vent is located on the rear of the tumble dryer.

This vent must never be covered or blocked with objects.



Keep the area around the tumble dryer – in particular the air intake – clear of fluff.

Useful tip: The Miele Cleaning Set is available as an optional accessory for effective and gentle cleaning of the tumble dryer.

Additional annual cleaning

The Miele Professional Service Department or a trained specialist must check the interior of the tumble dryer and the ducting for fluff deposits **once per year** and clean the machine if necessary. In the case of electrically heated tumble dryers, the heater bank and the heating shaft must also be checked by the Miele Professional Service Department. In the case of gas-heated dryers, the burner and the burner area must be checked.

Troubleshooting

Message	Possible cause and remedy
The display remains dark.	There is no power to the tumble dryer. <ul style="list-style-type: none"> ■ Check the electrical plug, main switch, and fuses (on site).
The // symbol appears in the time display after the tumble dryer is switched on. The <small>Start/Stop</small> sensor control pulsates.	The drying programme in progress was cancelled due to an interruption to the energy supply or by turning the programme selector to the  position. <ul style="list-style-type: none"> ■ Touch the pulsating sensor control <small>Start/Stop</small>. <p>The drying programme is resumed.</p>
Problem	Possible cause and remedy
The efficiency of the tumble dryer is decreasing.	The tumble dryer's fluff filter is soiled. <ul style="list-style-type: none"> ■ Check the tumble dryer's fluff filter for soiling and clean it.
	Insufficient ventilation <ul style="list-style-type: none"> ■ Make sure that the air intake vent and the tumble dryer ducting are not covered or blocked by objects.
	Room temperature too high (>40 °C) <ul style="list-style-type: none"> ■ Ensure adequate ventilation of the installation site. ■ Connect the tumble dryer to external air intake ducting and vent ducting.
Feather-filled pillows smell after drying.	Feathers tend to develop a build-up of their own smell or smells from other sources when they are heated. <ul style="list-style-type: none"> ■ Smells can be reduced through natural ventilation after drying.
Items made of synthetic fibres are charged with static electricity after drying.	Synthetic fibres tend to attract static charge. <ul style="list-style-type: none"> ■ Static charge can be reduced by adding a fabric softener to the final rinse in the washing programme.
Lightweight laundry sticks to the drum perforations during tumble drying.	If intermittent fan operation is not activated, air flow pressure can cause lightweight items of laundry like bed sheets or thin fabrics and cloths to stick to the drum perforations. <ul style="list-style-type: none"> ■ Touch the  sensor control. <p>Intermittent fan operation is activated. Lightweight items of laundry now fall away from the drum perforations.</p>
Fluff is caused by tumble drying.	Fluff is principally the result of friction when garments are being worn and to some extent when they are being washed. Tumble drying hardly causes any fluff to form. Fluff is collected by the fluff filter and can be removed easily. <ul style="list-style-type: none"> ■ See "Cleaning and care".
The drying process goes on too long or even switches off.	You are prompted to clean the air guide area. <ul style="list-style-type: none"> ■ Please check all the possible causes described below.
	The fluff filter is clogged with fluff. <ul style="list-style-type: none"> ■ Remove the fluff.
	The air guide area is clogged with hair and fluff, for example. <ul style="list-style-type: none"> ■ Clean the air guide area.

Problem solving guide

Problem	Possible cause and remedy
	<p>■ To clean the air guide area under the door opening, remove the cover.</p> <p>The vent ducting or its openings are clogged with hair and fluff, for example.</p> <p>■ Check and clean all components in the vent ducting (e.g. wall pipe, external grille, bends, elbows, etc.).</p> <p>The flow of air is insufficient (e.g. because it is installed in a small room).</p> <p>■ When drying, open a door or window to ensure sufficient ventilation.</p> <p>The laundry has not been spun sufficiently.</p> <p>■ In future, make sure that your laundry is thoroughly spun at the appropriate spin speed in the washing machine.</p> <p>The tumble dryer has been overloaded.</p> <p>■ Do not exceed the maximum load size for the drying programme selected.</p> <p>Metal zips can prevent the tumble dryer from registering the correct laundry moisture content.</p> <p>■ Open any zips next time.</p> <p>■ If the problem occurs again, dry garments with long zips using the hot air drying programme.</p>
<p>Condensation is forming in the drum.</p>	<p>The tumble dryer is installed on a shared exhaust air duct.</p> <p>■ The tumble dryer must always be installed with a non-return flap when using a shared duct.</p> <p>■ Check the non-return flap for possible defects on a regular basis and replace it if necessary.</p>

Contact in case of fault

In the event of any faults which you cannot remedy yourself, please contact Miele Professional Service.

Contact information for Miele can be found at the end of this booklet.

Please quote the model and serial number of your appliance when contacting Miele. This information can be found on the data plate.

Optional accessories

Optional accessories for this tumble dryer are available from the Miele Professional Service Department.

Installation

Installation requirements

⚠ Risk of injury or damage to property due to improper installation.

Incorrect installation of the tumble dryer can lead to personal injury or damage to property.

The tumble dryer must only be installed and commissioned by Miele Customer Service or an authorised specialist dealer.

- ▶ Suitable personal protective equipment must be worn during installation or maintenance.
- ▶ The tumble dryer must be installed in accordance with all relevant regulations and standards.
- ▶ The dryer must only be operated in a room that has sufficient ventilation and which is frost-free.
- ▶ The tumble dryer must not be installed behind a closeable door or a sliding door. The maximum opening angle of the tumble dryer door must not be limited by objects or doors. It must be possible to fully open the tumble dryer door at any time.

General operating conditions

This dryer is intended only for use in a commercial environment and must only be operated indoors.

Do not install the tumble dryer in a room where there is a risk of frost.

Depending on the nature of the installation site, sound emissions and vibration may occur.

Useful tip: Have the installation site inspected and seek the advice of a professional in instances where increased noise may cause a nuisance.

Transport

The tumble dryer must not be transported without a transport pallet. Suitable transport aids must always be used during transportation.

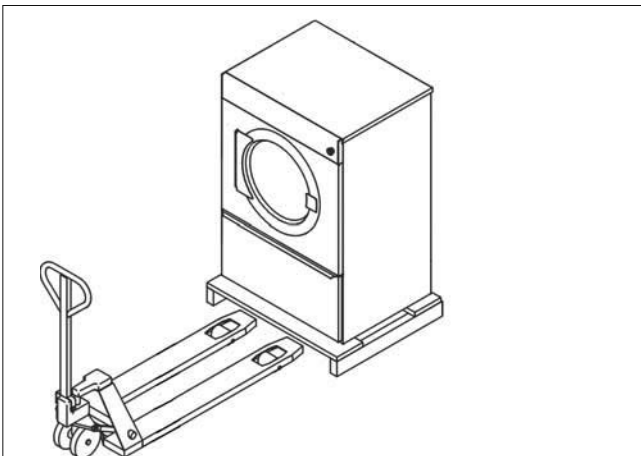

At the installation site, the tumble dryer must be lifted from the transport pallet using suitable lifting gear.

Installing the tumble dryer

- Place the tumble dryer on a perfectly level, secure, and horizontal surface that is able to withstand the specified floor load.

The floor load created by the tumble dryer is concentrated and transferred to the installation surface via the adjustable feet. A base is not required. However, an uneven floor surface must be compensated for.

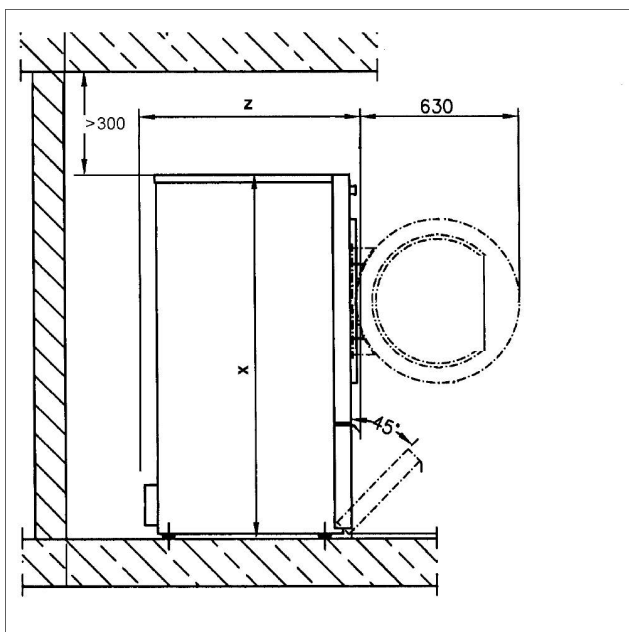
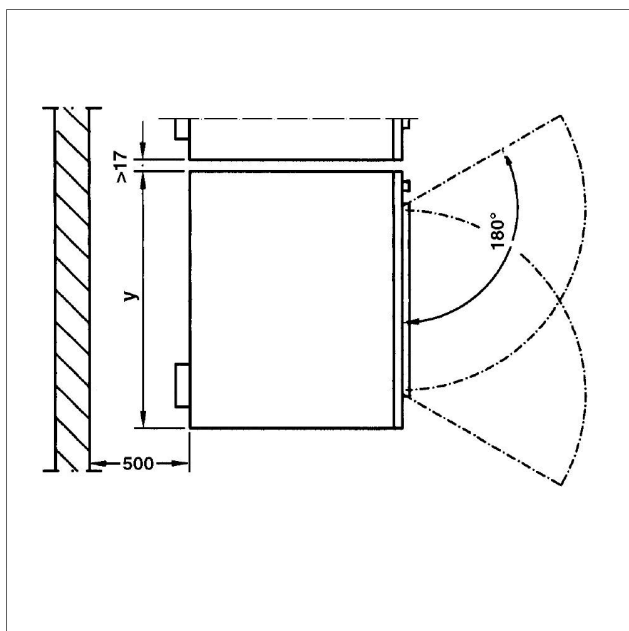

	PDR 514/518/522/914/918/922	PDR 528/544/928/944
x	1,400 mm	1,640 mm
y	906 mm	1,206 mm
z	PDR 514/914: 852 mm PDR 518/918: 1,035 mm PDR 522/922: 1,164 mm	PDR 528/928: 1,018 mm PDR 544/944: 1,384 mm

- To facilitate any future maintenance work, a maintenance corridor with a width of at least 500 mm must be set up behind the machine and must be accessible at all times. The distance between the machine and any walls must not fall below the specified minimum values.

Installation

- Adjust the tumble dryer feet until the machine is level. Use a spirit level to ensure correct alignment.

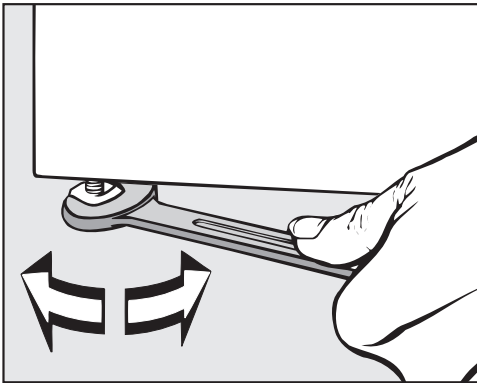

- After the machine has been aligned, screw the nuts on the adjustable feet tightly to the base plate using an open spanner.

Securing the tumble dryer

Gas-heated dryers and tumble dryers that are to be installed on a plinth must be secured against accidental displacement.

⚠ Risk of injury and damage due to missing tumble dryer fastenings.
When installing on a plinth, an unsecured tumble dryer can slip and fall off the plinth. If the tumble dryer is installed on a plinth, it must be secured.
The plinth must be secured to the floor.

⚠ Danger of gas leakage from gas-heated tumble dryers due to lack of floor fastening. Accidental displacement of a gas-heated tumble dryer can damage the gas line and cause gas to leak.
After installation, always secure gas-heated tumble dryers to the floor using suitable fastening material.

Gas tumble dryers must be secured to the floor via the adjustable feet using tensioning strips to secure them against accidental displacement.

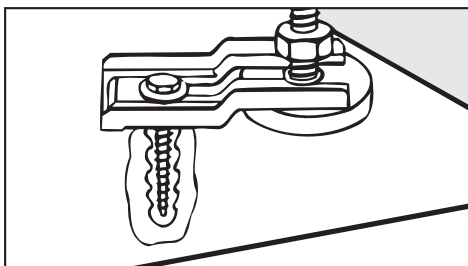

Electrical connection

⚠ Danger caused by improper electrical connection.
There is a risk of serious damage, injury, or even death if service work is carried out incorrectly.
All electrical work must be carried out by a suitably qualified electrician.

The electrical connection may only be made to an electrical system provided in accordance with all appropriate local and national legislation, regulations and guidelines. Please also observe the regulations set out by your insurance provider and energy supplier, accident prevention regulations, as well as recognised codes of practice.

Reliable and safe operation of this tumble dryer is only ensured if it has been connected to the mains electricity supply.

The required supply voltage, power rating and fuse rating can be found on the data plate on the tumble dryer. Ensure that the supply voltage matches the voltage quoted on the data plate before establishing the electrical connection to the machine.

Connection to a supply voltage other than the one quoted on the data plate can damage the tumble dryer if the voltage is too high.

If more than one voltage is specified on the data plate, the tumble dryer can be converted for connection to the relevant input voltage. This conversion must be performed by the Miele Professional Service Department or by an authorised technician. During the conversion, the wiring instructions given on the wiring diagram must be followed.

The tumble dryer is intended for hard-wiring but can be connected using a plug and socket. For a hard-wired connection, an all-pole isolation device must be available at the installation site.

When in the off position, this all-pole isolation device ensures a 3 mm gap between all open contacts. These include circuit breakers, fuses and relays.

If the mains supply cannot be permanently disconnected, the isolation device (including plug and socket) must be safeguarded against being switched on either unintentionally or without authorisation.

The tumble dryer must not be connected to devices such as timers which would switch it off automatically.

If the mains connection cable is damaged, it must be replaced by the manufacturer, its service agent or similar qualified persons in order to avoid a hazard.

Limitations to dryer operation due to reconnecting/removing jumpers.

Modifying/Removing jumpers on the heater elements in order to set lower heater ratings may result in limitations to dryer operation. Depending on the type of laundry, length of vent ducting, and outside temperature, the desired drying results may no longer be achieved. In the event of a reduction, the specified consumption data will no longer be achieved.

► For added safety, a type B residual current device must be connected upstream of the machine in accordance with the installation plan. Installation must be carried out on site by the operator.

► After installing the tumble dryer, equipotential bonding must be established. The equipotential bonding must comply with the local and national installation specifications.

Supply air/Exhaust air

The tumble dryer may only be operated when the ducting has been connected properly and the room is sufficiently ventilated.

Steam connection (only for steam-heated variants)

The steam connection must only be carried out by a registered installation technician. The enclosed installation instructions must be observed as they are important for the steam connection.

Hot water connection (only for hot water-heated variants)

The hot water connection may only be carried out by a registered installation technician. The installation instructions must be observed as they are important for the hot water connection.

Installation

If a tap is desired, it must be fitted on site.

Gas connection (only for gas-heated variants)

The gas connection may only be carried out by a registered installation technician in accordance with the applicable national regulations.

The use of a gas socket is not permitted at the specified heater rating as the flow rate is too low.

The gas heating is configured at the factory in line with the gas specifications on the sticker on the rear of the appliance.

If the gas type needs to be changed, please request the appropriate conversion kit from the Miele Professional Service Department. Information is required on the machine type, serial number, gas family, gas group, gas connection pressure and country of installation. This gas conversion may only be carried out by a registered specialist.

 Risk of electric shock and injury due to using the tumble dryer without the complete casing.





If the casing is dismantled, it is possible to come into contact with live or rotating machine parts.

Once the tumble dryer has been installed, replace all the casing parts that were removed.

Pairing instructions

Follow the steps below to connect the tumble dryer to your network.

Establishing the local network connection via WPS

- In the supervisor level, select *P91* using the < or > arrow sensors.
- Then select the internal communication module *-01* using the < or > arrow sensor.
- Confirm with the start/stop sensor.
- Restart the tumble dryer by turning the rotary control to the  position.
- Switch the appliance on again by turning the rotary control from the  position to any other position.
- Press and hold the  sensor for 4 seconds until *PPP* appears in the display.
- Then press and hold the  sensor for 2 seconds until *UPS* appears in the display.

A timer will then start.



- Press the WPS button on your router within the specified time.

The network connection via WPS is being established.

The machine is now successfully connected.

Establishing a temporary network connection via soft AP

The network connection via soft AP (software access point) is only possible if the tumble dryer is not already connected to a network.

- In the supervisor level, select *P91* using the < or > sensor controls.
- Then select the internal communication module *-01* using the < or > sensor control.
- Confirm with the start/stop sensor control.
- Restart the tumble dryer by turning the rotary selector to the  position.
- Switch the machine on again by turning the rotary control from the  position to any other position.
- Press and hold the  sensor control until *PPP* appears briefly in the display.

A timer will then start. The tumble dryer now opens the soft AP for 10 minutes.

- Establish the connection with the Device Connector in Miele MOVE.

Once a connection is established, dots flash in the *P.P.P* word.

Then continue with the Device Connector in Miele MOVE.

System requirements for Wi-Fi

- Wi-Fi 802.11b/g/n
- 2.4 GHz band
- WPA/WPA2 encryption
- DHCP activated
- Multicast DNS / Bonjour / IGMP snooping activated
- Ports 443, 80, 53, and 5353 open
- IP DNS server = IP standard gateway/router
- Mesh/Repeater use: same SSID and password as standard gateway/router
- SSID must be permanently visible

Networking



System requirements for LAN

- DHCP activated
- Multicast DNS / Bonjour / IGMP snooping activated
- Ports 443, 80, 53, and 5353 open
- IP DNS server = IP standard gateway/router

Wi-Fi signal strength – Guide values

The Wi-Fi signal strength is only a rough guide. These details do not provide absolute certainty.

The Wi-Fi signal strength can be read via the MDU or directly on the machine.

Wi-Fi signal strength		Meaning
MDU	 *	
76 - 100%	3/3**	Generally, reliable operation possible
51 - 75%	2/3	
26 - 50%	1/3	Generally, operation possible
1 - 25%	0/3	Generally, reliable operation not possible
0%		Operation not possible

* Displayed on the machine

** Number of bars  3/3–0/3

The signal strength can be adversely affected by many factors:

- People in the room
- Open or closed doors
- Moved objects
- Varying radio signal sources or interference
- Other machines with Bluetooth or Wi-Fi wireless technology

Communication box

The optional communication box allows external hardware from Miele and other suppliers to be connected to the Miele Professional machine. External hardware includes e.g. payment systems, peak-load systems, pressure sensors, or an external vent flap. The communication box is supplied with mains voltage by the Miele Professional machine. The separately available set consists of the communication box and fasteners for installation on the machine or on the wall.

APCL106

The optional Miele Communication Module can be used to establish a data connection between a Miele Professional machine and a data processor in accordance with the Ethernet or Wi-Fi standard.

This communication module fits into the communication slot which is a standard feature on all machines. The communication module offers the option of intelligent App-based communication with external systems (such as central smart payment terminals or payment systems). In addition, it can display detailed machine and programme status information.

This module forms the basis for wired communication with Miele MOVE*.

It is not possible to integrate the machine into the “Miele@home” App for domestic installations.

The communication module is intended exclusively for commercial use and is supplied with mains voltage directly via the Miele Professional machine. No additional power connection is required. The Ethernet interface provided via the communication module complies with SELV (safety extra low voltage) requirements in accordance with IEC 62368-1. Connected external machines must also comply with SELV.

* Not available in all countries

Data protection and data security

When you activate the networking function and connect your machine to the Internet, your machine sends the following data to the Miele Cloud:

- Machine serial number
- Machine model and technical features
- Machine status
- Information about the software status of your machine

Initially, this data cannot be assigned to a specific user and is not saved permanently. Data cannot be saved permanently or assigned to a specific user until after you have linked your machine to a user. Data transmission and processing are governed by Miele's strict security standards.

Factory default settings for network configuration

You can reset all of the settings on the communication module or your integrated Wi-Fi module to the factory default settings. The network configuration should be reset whenever a machine is being disposed of or sold, or if a used machine is being put into operation. This is the only way to ensure that all personal data has been removed and, in the case of the latter, the previous owner will no longer be able to access the machine.

Optional accessories

Copyright and licences

For the purpose of operating and controlling the communication module, Miele uses proprietary or third-party software that is not covered by open source licensing terms. These items of software/software components are protected by copyright. The copyright powers of Miele and third parties must be respected.

In addition, the communication module contains software components which are distributed under open source licensing terms. The open source components contained in the machine along with the corresponding copyright notices, copies of the licensing terms valid at the time and any further information can be accessed locally by IP using a web browser (*https://<IP address>/Licenses*). The liability and warranty arrangements for the open source licences displayed in this location only apply in relation to the respective rights holders.

Payment system

The tumble dryer can be fitted with a payment system (optional Miele accessory). In this case, a Miele Professional Service technician must programme the relevant settings in the tumble dryer's electronics and connect the payment system.

The Miele communication box accessory unit or the COM module is required to connect a payment device.

Original spare parts and accessories

Miele will guarantee to supply functional spare parts for up to 15 years following the discontinuation of your appliance (this does not apply to digital products or products for process documentation). In many cases, genuine Miele spare parts are available for much longer.

Miele machines are highly durable due to their excellent quality. If, however, repair work does become necessary, key functional spare parts will remain available for up to 15 years following discontinuation (this does not apply to digital products or products for process documentation).

Contact the Miele Professional Service Department if you need spare parts and accessories or would like personalised advice.

 Danger due to improperly performed service and repair work.

Service and repair work should only be carried out by a suitably qualified electrician in accordance with all appropriate safety requirements.

Servicing, modification, testing and maintenance of electrical appliances must be carried out in accordance with all appropriate legal requirements, accident prevention regulations and valid standards.

All live wires must be safely disconnected before any maintenance or repair work is commenced on the machine.

Technical data

	PDR 514	PDR 518	PDR 522	PDR 528	PDR 544
Height	1400 mm	1400 mm	1400 mm	1640 mm	1640 mm
Width	906 mm	906 mm	906 mm	1206 mm	1206 mm
Depth	852 mm	1035 mm	1162 mm	1019 mm	1385 mm
Depth with door open	1456 mm	1639 mm	1768 mm	1623 mm	1989 mm
Drum volume	250 l	325 l	400 l	500 l	800 l
Maximum load size (dry weight)	14 kg	18 kg	22 kg	28 kg	44 kg
Supply voltage					see data plate
Fuse rating (on site)					see data plate
Total rated load					see data plate
Test certifications awarded					see data plate
Product safety standard	AS/NZS 60335.1, AS/NZS 60335.2.11, EN 50570, ISO 10472-1 & ISO 10472-4				
Sound pressure level, EN ISO 11204					<70 dB (A)
Sound power level, EN ISO 9614-2					<80 dB (A)
Frequency band	2.4000 GHz – 2.4835 GHz				
Maximum transmission power					< 100 mW

Miele Australia Pty. Ltd.

ACN 005 635 398

ABN 96 005 635 398

Melbourne:

Level 4, 141 Camberwell Road

Hawthorn East, VIC 3123

Telephone: 1300 731 411

professional.service@miele.com.au

**www.miele.com.au/professional
professional.sales@miele.com.au**

Miele New Zealand Limited

IRD 98 463 631

8 College Hill

Freemans Bay

Auckland 1011

New Zealand

Telephone: 0800 4 MIELE

(0800 464 353)

www.miele.com.au/professional

professional.sales@miele.com.au



Miele Global Headquarters: Miele & Cie. KG
Carl-Miele-Straße 29, 33332 Gütersloh, Germany