

Miele

Operating instructions

PLW 7111



Before positioning, installing, and commissioning the device, it is **essential** to read the operating instructions to prevent damage to the device and ensure personal safety.

en – UK, IE, AU, NZ

Contents

1. GENERAL RULES	6
1.1 LIMITS OF LIABILITY	6
1.2 VALIDITY, CONTENTS AND STORAGE	6
2. PRODUCT INFORMATION.....	7
2.1 APPROPRIATE USE	7
2.1.1 FIELDS OF APPLICATION.....	8
2.2 SAFETY INSTRUCTIONS AND WARNINGS	8
2.2.1 APPROPRIATE USE.....	8
2.2.2 RISK OF INJURY.....	9
2.2.3 QUALITY ASSURANCE.....	10
2.2.4 USING COMPONENTS	11
2.2.5 DISPOSING OF YOUR OLD APPLIANCE	11
2.2.6 WARNING SIGNS	12
2.3 TECHNICAL DATA	13
2.4 RECOMMENDATION FOR PROPER OPERATION	15
2.5 TRAINING.....	15
2.5.1 USER PROFILES	16
2.6 RESIDUAL RISKS	16
2.7 TABLE OF SYMBOLS.....	18
3. MACHINE DESCRIPTION.....	19
4. INSTALLATION.....	20
4.1 WATER CONNECTION.....	20
4.1.1 WATER QUALITY.....	20
4.1.2 REQUIREMENTS	20
4.1.3 BUILT-IN SOFTENER.....	22
4.1.4 REFILLING THE SALT	22
4.2 ELECTRICAL CONNECTION	23
5. OPERATIONS.....	24
5.1 POWERING ON.....	24
5.2 CHECK WARNINGS AND FILL LEVEL.....	24
5.3 OPENING AND CLOSING THE DOOR.....	24
5.3.1 MANUAL DOOR VERSION	24
5.4 EMERGENCY DOOR RELEASE.....	25
5.5 PREPARATION.....	26
5.6 ADJUSTING THE UPPER BASKET.....	27
5.6.1 ADJUSTING TO THE LOWER POSITION	27
5.6.2 ADJUSTING TO THE MIDDLE POSITION	28
5.6.3 ADJUSTING TO THE UPPER POSITION	28
5.7 SMARTLOAD PLUS	28
5.8 CHECKS AFTER A PROGRAM.....	29
6. CHEMICAL PRODUCT TANK REPLACEMENT.....	30
6.1 RECOMMENDATION	30
7. CONTROL PANEL.....	32
7.1 CONTROL PANEL.....	32
7.1.1 SYMBOLS ON THE HEADER.....	33
7.1.2 SYMBOLS ON THE FOOTER.....	33
7.1.3 KEYBOARDS.....	35

8. CYCLE MANAGEMENT	36
8.1 OPERATOR LOGIN	36
8.2 CHANGE LANGUAGE	37
8.3 CYCLE START	37
8.3.1 CYCLE START: STANDARD VERSION	37
8.3.2 CYCLE START: AUTOMATIC VERSION	38
THE PROCEDURE IS THE SAME AS IN THE PREVIOUS SECTION.....	38
8.4 RESET PROCEDURE	39
8.5 ALERTS	40
8.6 CYCLE SCREENS	40
9. WASHING PROGRAMS	43
9.1 PROGRAM BLOCKS	45
9.2 PROGRAM OVERVIEW	46
10. MENU.....	49
10.1 MAIN MENU	49
10.2 FACTORY PROGRAMS.....	49
10.3 SPECIAL PROGRAMS.....	50
10.4 FAVOURITE PROGRAMS	50
10.5 LAST CYCLE	51
10.5.1 SAMPLING.....	51
10.5.2 EVENTS.....	52
10.5.3 TREND.....	52
10.5.4 PROGRAM DATA.....	53
10.5.5 WARNINGS	53
10.5.6 CONSUMPTION	53
10.5.7 CYCLE RE-PRINT	54
10.6 SYSTEM.....	55
10.6.1 UTILITY.....	55
10.6.2 MACHINE STATUS	56
10.6.3 MAINTENANCE.....	60
11. ALARM MESSAGES.....	62
11.1 DESCRIPTION OF ALARMS	62
11.2 LIST OF ALARMS	62
11.3 LIST OF WARNINGS	68
12. CONNECTIVITY.....	70
12.1 USB.....	70
12.1.1 USB REQUIREMENTS.....	70
12.1.2 WASHING CYCLE PRINT ON USB.....	70
12.1.3 SAVING HISTORICAL DATA ON USB.....	70
12.2 NETWORK CONNECTION.....	71
12.2.1 ETHERNET CONNECTION.....	72
12.2.2 WiFi CONNECTION	72
12.3 MIELE CLOUD	73
12.4 MIELE LOCAL DIAGNOSIS.....	74
13. MAINTENANCE.....	75
13.1 GENERAL RECOMMENDATIONS ON MAINTENANCE.....	75
13.1.1 MACHINE STATUS.....	75
13.1.2 SAFETY SYSTEMS	75
13.1.3 PROCEDURE	75
13.1.4 DECONTAMINATION PROCEDURES.....	75

13.1.5 MACHINE STATUS VERIFICATION	75
13.2 MAINTENANCE REMINDER	75
13.3 ROUTINE MAINTENANCE	77
13.4 DRYING AIR FILTRATION.....	84
13.5 CHANGING THE PAPER ROLL ON PRINTER.....	85
14. PROBLEMS – CAUSES – REMEDIES.....	87
14.1 INTRODUCTION	87
14.2 PROBLEM (P) – CAUSE (C) – REMEDY (R).....	87

1. GENERAL RULES

The laboratory glassware washer is generally referred to as “the machine” in these operating instructions. Reprocessable laboratory glassware and utensils are referred to as “load items” if they are not more specifically defined.

1.1 Limits of liability

The manufacturer shall not be held liable for failures or problems which arise due to tampering and/or incorrect applications and/or improper use of the machine.

The operator must comply with all instructions set forth in the operating instructions, most notably:

- ▶ Always follow the intended use of the machine
- ▶ Always carry out the required maintenance work
- ▶ Use of the machine should be limited to persons who have been properly trained and instructed on use of the machine
- ▶ Use only original spare parts

Any modifications, adaptation or other which may be made to machines subsequently placed on the market do not oblige the manufacturer to intervene on previously supplied machines, or to consider the machine and related user manual lacking and inadequate.

The operating instructions on the following pages are designed to guarantee the longevity and functionality of your machine.

The instructions in this manual do not replace, but rather supplement the employer requirements in order to adhere to current health and safety legislation.

Refer to the general conditions of sale for information on the warranty.

1.2 Validity, contents and storage

It is very important to keep this instruction manual with the machine for future reference.

If the machine is sold or transferred, the manual must be handed over to the new owner or user in order that they can become acquainted with its operation and the relative warnings.

Read the instructions carefully before installing and using the machine.

This is a translation of the Italian text, which prevails in case of doubt.

In order to prevent possible accidents to persons or property due to incorrect translation of the instructions, the client must:

- ▶ not perform operations or manoeuvres with the machine in case of doubt or uncertainty regarding the operation to be performed
- ▶ ask the Miele after-sales service for clarifications on the instruction.

2. PRODUCT INFORMATION

Before starting work, the user must be completely familiar with the functions and proper operation of the machine. The user must know the precise functions of all command and control devices of the machine.



2.1 Appropriate use

This machine is used to reprocess laboratory glassware and laboratory utensils using water. The process includes cleaning, rinsing and, where required, disinfection and drying.

These machines are designed for use in laboratory as well as laboratory type application in the industrial sector.

Due to the wide variety of laboratory glassware and laboratory utensils on the market, it may be necessary in some cases to establish whether the item is suitable for reprocessing in a laboratory glassware washer.

This will depend on its use and the type of soiling present as well as the disinfection parameters. Please refer to the information provided by the manufacturer of the laboratory glassware and laboratory utensils.

Laboratory glassware and laboratory utensils suitable for reprocessing include:

- ▶ Vessels such as test tubes, beakers, flasks, cylinders, etc.
- ▶ Measuring vessels such as measuring cylinders, pipettes, volumetric flasks, etc.
- ▶ Dishes such as Petri dishes, watch glasses, etc.
- ▶ Plates such as slides, sequencing plates, etc.
- ▶ Small items such as lids, spatulas, magnetic stirring rods, stoppers, etc.

- ▶ Other items such as funnels, pipe/hose pieces, etc.

Information note: The ISO 17664 standard: 2004 defines the responsibility of the manufacturer of the reusable laboratory glassware in providing all the instructions for its proper reprocessing and maintenance after use. This is the information for the correct preparation, treatment, drying, and storage phases.

2.1.1 Fields of application

- ▶ Laboratories in schools, colleges and universities
- ▶ Research, quality assurance, development, technology and production
- ▶ Different areas of inorganic, organic, analytical and physical chemistry
- ▶ Biology, microbiology and biotechnology
- ▶ Hospital laboratories
- ▶ Industries

Reprocessing conditions must be suitable for the load and type of soiling. Process chemicals must be suitable for the type of soiling.

The use of a suitable load carrier (basket, module, insert, etc.) is important to ensure adequate reprocessing of the load.

The machine can be qualified for process validation.

The machine fulfils the requirements of the EU Machinery Directive 2006/42/EC.



WARNING

Any use other than that for which the machine is intended is forbidden.

Inappropriate use can lead to personal injury and damage to property.

Miele cannot be held liable for damage caused by improper or incorrect use or operation of the machine.

2.2 Safety instructions and warnings

This machine complies with all statutory safety requirements. Inappropriate use can lead to personal injury and damage to property.

Read the operating instructions carefully before using this machine. This will prevent both personal injury and damage to the machine.

Keep these instructions in a safe place where they are accessible to users at all times.

2.2.1 Appropriate use

- ▶ Use of the machine is only approved for the applications stated in the operating instructions. Alterations or conversion of the machine, or its use for purposes other than those intended, are not permitted and could be dangerous.
- ▶ The cleaning and disinfection processes are only designed for laboratory glassware and utensils which are designated as re-processable by the manufacturer. The information provided by the manufacturer of the load items must be observed.
- ▶ Miele cannot be held liable for damage caused by improper or incorrect use or operation of the machine.
- ▶ This machine is intended for indoor use only.

2.2.2 Risk of injury

Please pay attention to the following notes to avoid injury

- ▶ The machine should only be installed, commissioned, repaired and maintained by the Miele Customer Service Department or a suitably qualified service technician. A Miele service contract is recommended to ensure full compliance with the normative and regulatory provisions. Incorrect repairs can cause considerable danger to users.
- ▶ Do not install the machine in areas where there is any risk of explosion or freezing conditions.
- ▶ In order to reduce the risk of water damage, the area around the machine should be limited to furniture and fittings designed for use in commercial environments.
- ▶ Some of the metal parts pose a risk of injury or cutting. Wear cut-resistant protective gloves when transporting and setting up the machine.
- ▶ The electrical safety of the machine can only be guaranteed when it is correctly earthed. It is essential that this standard safety requirement be observed and regularly tested. In case of doubt, have the electrical installation inspected by a qualified electrician. Miele cannot be held liable for the consequences of an inadequate earthing system (e.g. electric shock).
- ▶ A damaged or leaking machine can pose a threat to your safety. Always switch off a damaged or leaking machine immediately and contact the Miele Customer Service Department.
- ▶ Machine operators must be instructed on how to use the machine and receive regular training. Untrained personnel must not be allowed to access the machine or its controls.
- ▶ Use only process chemicals which have been approved by their manufacturer for the relevant application. The manufacturer of the process chemicals is liable for any negative influences on the material of the load and the machine.
- ▶ Take care when using process chemicals. Some chemicals may be caustic, irritating and toxic.
The relevant safety regulations and safety data sheets issued by the process chemical manufacturers must be observed. Wear gloves and protective goggles.
- ▶ The machine is designed for use only with water and appropriate process chemicals. The use of organic solvents or inflammable liquids is not permitted. This could cause an explosion or damage rubber or plastic components in the machine and cause liquids to leak out.
- ▶ The water in the washing chamber must not be used as drinking water.
- ▶ Do not lift the machine by its protruding parts such as the door handle or the opened service flap as these could be damaged or torn off.
- ▶ Do not sit or lean on the opened door. This could cause the machine to topple over and be damaged, or cause personal injury.
- ▶ Be careful when arranging items with sharp, pointed ends. Position them in the machine in such a way as to avoid injuring yourself or others.
- ▶ Broken glass can result in serious injury when loading or unloading. Broken glass items must not be processed in the machine.
- ▶ Please be aware that the machine may be operating at high temperatures. Deactivating the lock to open the door can create a risk of burning or scalding, or contact with corrosive substances. Where disinfectant is in use, there is also a risk of inhaling toxic vapours.
- ▶ Should personnel accidentally come into contact with toxic vapours or process chemicals, follow the emergency instructions given in the manufacturer's safety data sheets.
- ▶ Load carriers such as baskets, mobile units and inserts must be allowed to cool down before they are unloaded. Any remaining water in the containers could still be very hot. Empty this water into the washing chamber before removing items.
- ▶ Never clean the machine or nearby with a water hose or a pressure washer.

- ▶ The machine must be disconnected from the power supply before any maintenance or repair works are carried out.

2.2.3 Quality assurance

The following points should be observed to assist in maintaining quality standards when reprocessing laboratory glassware and utensils and to avoid damage to the loads being cleaned.

- ▶ Only authorised personnel may interrupt a program in exceptional circumstances.
- ▶ It is the responsibility of the operator to demonstrably ensure reprocessing standards in routine operation. Process results must be inspected and documented on a regular basis.
- ▶ For thermal disinfection, use temperatures and temperature holding times to achieve the required infection prophylaxis in accordance with current health and safety regulations.
- ▶ Only reprocess undamaged and suitable items. When washing plastic items, ensure they are thermally resistant. Nickel-plated and aluminium items require special procedures and are not generally suitable for machine reprocessing. Ferrous materials that can rust or corrode must not be introduced into the washing chamber as washing items or soiled items.
- ▶ Under certain circumstances, process chemicals may damage the machine. Users are urged to follow the recommendations issued by the manufacturers of process chemicals. Contact Miele in the event of damage and any suspicion of material incompatibility.
- ▶ Cleaning agents containing chlorine can damage the elastomers of the machine. If cleaning agents containing chlorine need to be used, a maximum temperature of 70 °C in the “Main washing” program blocks is recommended (see program chart).
- ▶ Abrasive substances should not be introduced into the machine as these could damage mechanical components in the water circuit. Any abrasive residue on the load must be completely removed before reprocessing.
- ▶ During pre-treatments with cleaning or disinfecting agents, certain types of stains and the interaction of certain process chemicals can create foam. Foam can have an adverse effect on the disinfection and cleaning result.
- ▶ Reprocessing should not result in foam being discharged from the chamber. Foam discharge can compromise the machine's operation.
- ▶ The process used must be monitored on a regular basis by the operator to check foaming levels.
- ▶ Even when a process chemical, e.g. detergent, is recommended, Miele takes no responsibility for the effect of such chemicals on the load items. Please note that changes in product formulation, storage conditions, etc., which are not announced by manufacturers of process chemicals may impair the quality of cleaning results.
- ▶ Always follow the relevant manufacturer's instructions on the storage and disposal of process chemicals.
- ▶ In critical applications where very stringent requirements have to be met, it is strongly recommended that all relevant factors for the process, such as detergents, water quality, etc., be discussed with Miele.
- ▶ If the cleaning result is subject to particularly stringent requirements (e.g. chemical analysis), quality control should be regularly carried out by the operator to ensure the required standards of cleanliness are achieved.
- ▶ Load carriers such as mobile units, baskets and inserts which hold the load must be used only as intended.
Lumened items must be thoroughly cleaned, internally and externally.
- ▶ Secure small and light items with covering nets or place them in a mesh tray for small items, so that they do not block the washing arms.
- ▶ Empty any containers or utensils before loading them.

- ▶ The amount of residual solvents on items going into the washing chamber should be minimal.
There should be no more than a trace of any solvents with a flash point below 21 °C.
- ▶ Chloride solutions, in particular hydrochloric acid, or ferrous materials subject to rust or corrosion must not be placed in the chamber.
- ▶ Ensure that solutions containing chlorides or hydrochloric acid do not come into contact with the stainless steel outer casing of the machine in order to avoid any damage due to corrosion.
- ▶ After any plumbing work, the water pipework to the machine will need to be vented. If this is not done, the machine's components may be damaged.
- ▶ Follow the installation instructions in the installation plan and service manual.
- ▶ If an accident occurs while using the device, notify the manufacturer and the competent authorities.

2.2.4 Using components

- ▶ Only use genuine Miele original spare parts and components suitable for their intended application. Model designations are available from Miele.
- ▶ Only use Miele load carriers, such as mobile units, baskets, modules and inserts. Using mobile units, baskets and inserts made by other manufacturers or making modifications to Miele components can result in unsatisfactory cleaning and a poor disinfection result. Any resulting damage would not be covered by the warranty.

2.2.5 Disposing of your old appliance

Please note that the machine may contain contamination from blood and other bodily fluids, pathogens, facultative pathogens, genetically modified material, toxic or carcinogenic substances, heavy metals, etc., and must be decontaminated before disposal.

For environmental and safety reasons, dispose of all process chemical residue in accordance with safety regulations. Wear gloves and protective goggles.

Make the door lock inoperable, so that children cannot accidentally shut themselves in. Then make appropriate arrangements for safe disposal of the machine.

Old electrical and electronic appliances often contain valuable materials. However, they also contain harmful substances which were essential for their correct functioning and safety. These could be hazardous to human health and to the environment if disposed of with general waste or if handled incorrectly. Please do not, therefore, dispose of your old appliance with general waste.



Make use of local waste collection/recycling centres for electrical and electronic devices. Consult your dealer if necessary. National legislation may require the deletion of personal data saved on the machine before disposal. Please ensure that your old appliance poses no risk to children while being stored prior to disposal.

2.2.6 Warning signs

To inform operating personnel of their obligations and to warn of residual risks, the machine is equipped with safety labels in accordance with the relevant legislation (Directive 92/58 EEC).

General warning signs

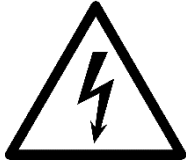

Caution!
**Danger of electric
shock!**



Caution!
**Observe the operating
instructions!**



Caution!
Hot surfaces!

The health and safety risk assessment carried out on-site, as well as the evaluation of residual risks, determines the safety equipment which the supervisor must provide for the user.

Miele cannot be held liable for damage or injury caused by non-compliance with the safety instructions and warnings.

2.3 Technical data

Dimensions	External W x D x H 650 mm x 700 mm x 1940 mm
Weight	Net weight: 289 kg Max during operation: 309 kg
Average sound pressure level	< 70 dB(A)
Protection rating (according to IEC 60529)	IP00
Backflow preventer (according to EN 1717)	AB – Air gap not limited
Operation	Temperature range +5 to +35 °C Relative humidity range Max 80% (5 ÷ 31°C); 80...50% (31...35°C) Maximum altitude: 2000 m (special device settings are available for higher altitudes)
Ambient lighting requirements	500 ... 1500 lux
Installation site air exchange requirements	min 10 air exchanges / hour
Electrical connection	See the device's data plate
Storage and transportation conditions	-5 ... +50 C 20 % to 90 % non-condensing Ventilation: Non-influencing air exchange (only required if any supplied containers of chemical products are installed).
Overvoltage category (according to IEC EN 60664)	II
Pollution level according to EN 61010	II
Equipment Class (according to CISPR 11)	A
Equipment Group (according to CISPR 11)	1
Manufacturer's address	Steelco S.p.A Via Balegante, 27 31039 Riese Pio X (TV), Italy
Control system data	Microcontroller: STM32F767BGT6 (*) CPU: Core: Arm® 32-bit Cortex®-M7 (216MHz max) Internal RAM: 512 KB Internal FLASH: 1MB External program flash: 64Mb External data flash: 256Mb External SDRAM: 16MB



WARNING

Any use of the machine not within the recommended ambient conditions is forbidden.

Inappropriate ambient conditions can damage the machine.

The machine is certified according to EN 61326 for electromagnetic compatibility. If the device is exposed to an electromagnetic field out of the range for which it is certified, it can be damaged, or its functionality cannot be guaranteed.

In case of exposure to conditions not within the recommended ones, contact technical assistance for a general check of the device.

2.4 Recommendation for proper operation

- ▶ The user must supervise the machine during operation.
- ▶ Before starting the cycle, the operator must always check that the water filters are in the well and properly positioned.
- ▶ To prevent contact with contaminated material, appropriate personal protective equipment must be worn during reprocessing.
- ▶ Do not reprocess items containing substances which, in accordance with current legislation, must not be discharged into the sewage system. These substances must be disposed of separately.
- ▶ Follow the manufacturer's instructions, as well as national requirements and guidelines relating to the machine-based reprocessing of loaded items.
- ▶ The machine is designed for use with water and process chemicals.
- ▶ Check that the type of chemical product is suitable for the specifications of the washing program used.
- ▶ Do not use powder cleaning agents.
- ▶ Do not use domestic detergents.
- ▶ Components which are not approved by the manufacturer may compromise reprocessing results as well as user safety.
- ▶ The user must carry out a general check-up and clean the appliance regularly as indicated in the maintenance instructions.
- ▶ Visually check the load for cleanliness.
- ▶ The on-site stopcock must be easily accessible so that the inlet can be turned off when not in use.
- ▶ If the new machine appears to be damaged, contact your dealer before installation.
- ▶ Any modifications to the electrical and hydraulic systems, which are necessary in order to install the machine, must be carried out by qualified and authorised persons only.
- ▶ The user is forbidden to carry out any repairs.
- ▶ If the machine shows an alarm that cannot be easily solved, technical assistance must be contacted.
- ▶ If the machine is not working properly, contact technical assistance.
- ▶ Technical assistance on this machine should only be carried out by qualified and authorised service partners.

ATTENTION: chemical products are irritating to the eyes, in case of contact wash abundantly with water and consult a doctor; in case of contact with the skin, wash with plenty of water.

The manufacturer declines any liability for accidents to persons or property arising from failure to comply with the above-mentioned rules.

Failure to comply with the rules results in the immediate and total cancellation of the warranty.

2.5 Training

Instructions for use of the machine will be provided by the Miele Customer Service Department or an authorised service technician during machine commissioning.

It is the duty of the responsible body to ensure that users are sufficiently trained and instructed.

The responsible body must record and archive the training sessions, including evidence that the contents have been understood.

2.5.1 User profiles

User profiles are identified as follows:

SUPERVISOR

Senior service technician:

Special machine settings can only be made by the Miele Customer Service Department, such as the installation of new functions.

MAINTENANCE ENGINEER

Service technician:

The machine may only be installed, commissioned, repaired and maintained by the Miele Customer Service Department or an authorised service technician.

DEPARTMENT MANAGER

Responsible for the machine in the workplace:

More advanced tasks, e.g. interrupting or cancelling a program, require more detailed knowledge of machine reprocessing of laboratory glassware and utensils.

Alterations or adaptations of the machine, e.g. to components used or on-site conditions, require additional specific knowledge of the machine.

Validation processes assume specialist knowledge about machine reprocessing of laboratory glassware and utensils, the processes involved and applicable standards and legislation.

OPERATOR

User:

Users must be instructed on operating and loading the machine, and receive regular training to guarantee safe daily use.

They must have knowledge of machine reprocessing of laboratory glassware and utensils.

2.6 Residual risks

The OPERATOR, in normal operating conditions, is not exposed to risks if they work safely, using the appropriate means of protection.

In order to operate safely, the operator must:

- ▶ Carefully comply with the instructions set forth in this manual.
- ▶ Use safety devices appropriately and with care, and the group and individual safety gear provided in the workplace.
- ▶ Personally take action or report to responsible staff in the event of deficiencies in the aforementioned devices and means, as well as any hazardous conditions of which they may become aware, taking immediate action in urgent cases within their scope of responsibility and ability, to eliminate or reduce the deficiencies or hazards.











The laboratory glassware washer is nonetheless considered to have some residual risks. Below is a list of the appropriate measures to be taken for each phase or significant action of work:

PHASE	BASKET LOADING
RISK	Bruising and cutting of the upper limbs, caused by accidental contact due to a fall or impact against tools and objects and instruments, mainly during basket handling operations.
MEASURE	Enable only trained personnel with the necessary equipment for this type of operation (e.g. baskets with protections, transport mobile units) and appropriate clothing and PPE (e.g. protective overalls and gloves).

PHASE	DOSING OF DETERGENTS/CHEMICAL ADDITIVES
RISK	Contact of body parts with washing chemicals.
MEASURE	Assign staff that is trained and equipped with appropriate clothing and PPE. Wear safety clothing, gloves and goggles and comply with the safety instructions set out by the manufacturer of the chemical products.
FIRST AID MEASURE	<ul style="list-style-type: none"> ▶ Remove/immediately remove clothes that have been contaminated or soaked with the product. ▶ If the substances come into contact with the skin, wash off the affected areas immediately and rinse with water.
RISK	Inhaling of washing chemical vapours.
MEASURE	Assign staff that is trained and equipped with appropriate clothing and PPE. Comply with the safety requirements specified by the manufacturer of the chemicals, and if foreseen, wear a suitable protective mask to protect the airways.
RISK	Accidental release of washing chemicals.
MEASURE	Do not disperse the concentrated chemical into drains or directly on surfaces; Collect any spilled fluid with absorbent material (e.g., sand, earth, sawdust); Rinse the residual chemical with plenty of water.
	IN CASE OF CONTACT WITH THE BODY OR RELEASE OF CHEMICAL PRODUCTS, ALWAYS REFER TO THE SAFETY MEASURES INDICATED IN THE PRODUCT DATA SHEET.
PHASE	DAMAGE TO THE DEVICE
RISK	Use of inappropriate components, detergents, washing processes.
MEASURE	Use suitable components that do not damage the surface of the device and check its integrity. Use the chemical product in the quantity and manner prescribed by the manufacturer and follow instructions regarding the compatibility of the material.
PHASE	INCORRECT CONNECTION OF CHEMICAL PRODUCTS
RISK	Use of the incorrect chemical for the process when changing the chemical tank.
MEASURE	Use of a colour code for the chemical caps to help the operator when replacing the chemicals.

2.7 Table of symbols

Symbols applied to the machine

	Electrical shock risk
	Warning: hot surface
	Manufacturer
	Date of manufacture
	Warning! See the accompanying documentation for important cautionary notices, such as warnings and precautions.
	Consult the user instructions
	Earth terminal
	CE mark Indicated on the serial number label
	WEEE waste disposal
	It indicates the final product code of the device. It is reported in the serial number label. The "COD" corresponds to the article code in the system (AS 400) and in the sales invoice. This code can be variable depending on the configuration/specifications required by the customers.
	Indicate the number of the product model. Indicated on the serial number label

3. MACHINE DESCRIPTION



- ① Control panel
- ② USB port
- ③ Door
- ④ Chamber - access to chamber filters and washing arms
- ⑤ Main switch (behind maintenance flap)
- ⑥ Technical compartment panel - access to chemical & air filters area
- ⑦ Printer

4. INSTALLATION

4.1 Water connection

4.1.1 Water quality

The quality of the water used in all stages of cleaning is essential in achieving good results.

- The water must be compatible with the material of which the machine is made.
- The water must be compatible with process chemicals.
- The water must be compatible with process requirements for the various stages of the process.

In order to achieve good reprocessing results, the machine requires a supply of soft water with a low calcium content. Hard water causes the build-up of calcium deposits on the load and in the machine. Water with a hardness level higher than 0.7 mmol/l (7 °fH – French scale or 4 °dH – German scale) must be softened. This automatically occurs during a program sequence on machines with a built-in water softener (ex works option). The water softener must be set to the exact hardness of the water supply.

The water softener must be regenerated at regular intervals. This requires the use of special regeneration salt. The regeneration is carried out automatically during a program sequence.

Softened water must be provided on-site for machines without a built-in water softener.

The maximum allowed water hardness is 65 °fH or 36 °dH.

Note: The water hardness is set by the Miele Customer Service Department.

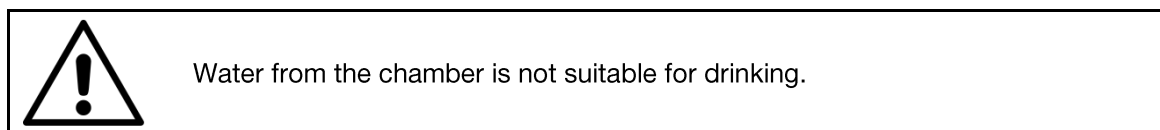

4.1.2 Requirements

- ▶ The machine must be connected to the water supply in strict accordance with local regulations
- ▶ The water used must comply with European regulations for drinking water quality, as a minimum. If the water supply has a high iron content, there is a danger of corrosion on the items being cleaned in the machine, as well as the machine itself. If the chloride content of the water exceeds 100 mg/l, the risk of corrosion on the load in the machine will be further increased.
- ▶ Use only the hoses supplied with the machine
- ▶ Do not shorten the hoses supplied with the machine
- ▶ The **minimum flow pressure** for cold water, hot water and demineralised water connections is 100 kPa.
- ▶ The **recommended flow pressure** is ≥ 200 kPa for the cold and hot water connections and ≥ 200 kPa for the demineralised water connection in order to avoid excessively long water intake times and to guarantee the best performance of the steam condenser (if installed).
- ▶ The **maximum permissible static water pressure** is 600 kPa.
- ▶ A booster pump is required for the demineralised water connection if the flow pressure is below 100 kPa.
- ▶ If the machine is equipped with a booster pump, but the pressure on the demineralised water tap is higher than 1 bar, disconnect the booster pump, otherwise the component could be seriously damaged.

- ▶ If the pressure is higher than 600 kPa (8 bar), a pressure reducer must be installed.
- ▶ If the water pressure is not within the specified range, contact the Miele Customer Service Department or an authorised service technician for advice.
- ▶ A water valve with a 3/4" male threaded fittings must be provided on-site. The valve should be easily accessible, since the water supply should be shut off whenever the machine is not in use.



Do not overtighten the threaded fittings on the hoses.

Information:

- ▶ The anti-return water system is already installed inside the appliance in accordance with the IEC 61770 standard.
- ▶ If no hot or demineralised water supply is available, the **red** or **white** coded inlet valves should be closed with a cap supplied with the machine.



The hot or demi water absence must be set in the machine settings: in this case the machine automatically fills cold water instead of the non-connected water type. In this case, the non used water hoses do not need to be assembled.

If no cold water supply is available, or the hardness of the water is higher than specified in the installation plan, and the machine is not equipped with a water softener, the **blue** coded inlet valve should be closed with a cap supplied with the machine.

The water absence needs to be set in the machine settings, in order to allow the machine to automatically fill the alternative water.

- ▶ Non-compliance with the above conditions shall render the warranty invalid.



When the machine is not in operation, always close the stopcocks.

4.1.3 Built-in softener

The purpose of the built-in softener is to reduce the quantity of limescale contained in the supply water used for washing and thermal disinfection. The laboratory glassware washer, if fed with particularly hard water, quickly degenerates, compromising its functionality and service life. To keep the resins that perform the descaling activity active, they must be regenerated as described in the table.

For machines equipped with this device, the value corresponding to the water hardness must be set at the time of installation, as follows:

WATER HARDNESS (°fH)	WATER HARDNESS (°dH)	PARAMETER SETTING
7 - 15	4 - 8	6
16 - 30	9 - 17	4
31 - 50	18 - 28	2
51 - 65	29 - 37	1

4.1.4 Refilling the salt

For the regeneration of the water softener, use only appropriate salt e.g. Miele ProCare Universal 61. Alternatively use special, coarse-grained dishwasher salt or other pure evaporated salt for regeneration. Never use any other kind of salt, e.g. table salt, animal feed salt or de-icing salt. Other salts may contain insoluble additives which can impair the functionality of the water softener

The following prompt reminds the user to refill the salt container: “salt loading needed”

This warning will appear at the beginning of each cycle for three times to remind the needs of a salt refilling, then will be automatically canceled.

The container for dishwasher salt is located in the base of the washing chamber inside the machine.

- ▶ Open the door.
- ▶ Remove the load carrier.
- ▶ Unscrew the plastic cap on the container.
- ▶ Fill the funnel with salt.
- ▶ Raise the funnel and place it on the container to transfer the salt.
- ▶ Repeat the process until the container is visibly full.

The supply container contains approx. 800 g of salt.



The container must always be completely filled. If the salt quantity is insufficient, the water softening capacity is reduced and limescale may be deposited on the load and on washing chamber surfaces.

- ▶ Refit the plastic cap on the salt container and screw it in tightly.
- ▶ Place the load carrier in the machine.
- ▶ Start the “Rinse Cold Water” program.



Always run the “Rinse Cold Water” program after refilling the salt. This removes and dissolves any spilled salt and brine. Excess salt and brine which has overflowed can cause corrosion damage if not rinsed away.



During regeneration, the following symbol appears on the control panel:



4.2 Electrical connection



Only qualified, skilled personnel may connect the machine to the power supply

- ▶ It is recommended that the machine be connected to the mains electrical supply via a suitably rated plug and socket compliant with all local and national standards.
- ▶ The machine must only be operated with the voltage, frequency and fuse rating shown on the data plate.
- ▶ The electrical connection must be made according to the technical regulations in force.
- ▶ The power supply voltage must not differ from its nominal value by more than $\pm 10\%$.
- ▶ The frequency of the power supply must not differ from its nominal value by more than 1 %.
- ▶ The electrical safety of the machine can only be guaranteed when it is correctly earthed. Equipotential bonding is required.
- ▶ Make sure that the electrical systems are properly earthed.
- ▶ The earth conductor is to be connected to the earth terminal identified by the standard symbol.
- ▶ The machine is equipped with a terminal identified by the relative symbol for equipotential connections between appliances (see rules for electrical systems), placed on the lower technical compartment, on the solenoid valve bracket
- ▶ The machine is equipped with a power cable
- ▶ Machines that are permanently connected (without a plug) must be connected via a power switch with all-pole isolation. The power switch must be designed to operate at the rated current.
- ▶ For increased safety, it is recommended to protect the machine with a suitable residual current device (RCD) with a trip current of 30 mA (DIN VDE 0664)
- ▶ The installed safety device must be equipped with fuses according to the specification indicated in the Installation plan and Wiring diagram
- ▶ The machine should be disconnected from the power supply when not used for long periods of time.
- ▶ The electrical connection and fuse rating must comply with local and national regulations.



Please refer to the installation plan provided.

5. OPERATIONS

5.1 Powering on

To turn on the machine, follow the steps below:

- ▶ Activate the main switch located in the technical compartment behind the lower door.

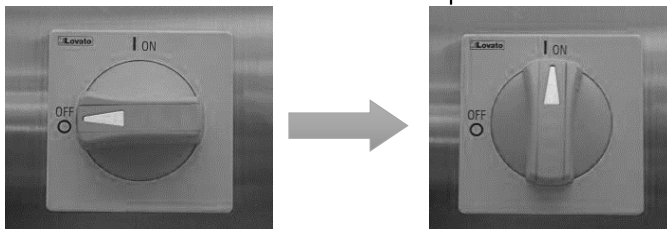

- ▶ Once the switch is activated, the control panel automatically starts.
- ▶ *Take note of any fault or warning messages on the control panel when starting the machine.*

5.2 Check warnings and fill level

Check that no warnings are active on the control panel, in particular regarding low-level chemical products or the lack of salt, and if necessary, replace the tank and fill the salt box operating as described in this manual.



Take care when using process chemicals. Some agents may be corrosive and irritating. The relevant safety regulations and safety data sheets issued by the process chemical manufacturers must be observed. Wear protective gloves and goggles.

5.3 Opening and closing the door

The door is made of high-strength tempered glass. A particular manufacturing test (HST) certifies its integrity and robustness.

The thermal dispersion of the glass has been contained thanks to the use of a special material with a low dispersion coefficient.

Nevertheless, particular attention is recommended during use, due to the danger of burns.



ATTENTION

- ▶ During normal use, be careful not to sharply strike the glass door, as there is a risk of breakage.
- ▶ Slowly insert the basket inside the washing chamber to avoid the risk of breaking the glass door
- ▶ Place the load in the basket in such a way that it does not protrude, avoiding striking the glass door.
- ▶ Before opening the door, make sure that the opening area is free from obstructions.

5.3.1 Manual door version

Use the handle to open and close the door.

The door is automatically locked after the cycle starts by means of a door lock and cannot be opened for the entire duration of the cycle.

To open the door during cleaning, the cycle must be interrupted, remembering that:

- ▶ The material inside the machine may be very hot.
- ▶ It will subsequently be necessary to repeat the complete washing cycle.



ATTENTION

Always use the handle to close the door.

Do not place your fingers between the door and the washing chamber, as there may be a risk of crushing

5.4 Emergency door release

The emergency release may only be used when it is no longer possible to open the door normally, e.g. in the event of a power outage.



If the emergency release is operated during a program sequence, hot water and process chemicals can escape.

The load, the load carrier and the washing chamber may be very hot. Danger of scalding, burning and chemical burns. Where disinfecting agents are used, there is also a danger of inhaling toxic fumes.

In the **manual door version**, an emergency door release system is available in case of a power failure. There is a hole above the upper right of the door (see picture).

- ▶ Insert a screwdriver and unscrew the screw of the door lock
- ▶ Open the door
- ▶ When the power is restored, an alarm will appear on the control panel to advise that the door has been manually unlocked
- ▶ Reset the alarm and the machine will automatically unlock the door. Tighten the screw of the door lock to restore regular door operation.





ATTENTION

A cycle that has been interrupted due to a power failure, with subsequent manual opening of the door, must be considered failed.

The cycle must be run again.

5.5 Preparation

- ▶ Follow the manufacturer's instructions for reprocessing.
- ▶ Make sure that the items are suitable for reprocessing in a laboratory glassware washer machine and check their compatibility with the chemicals used during the washing programs.
- ▶ Carefully place the items into the load carriers.
- ▶ Make sure that load items are not shielded or concealed by other items.
- ▶ Position the load items in such a way that fluids can drain off freely.
- ▶ Tall or heavy items should be placed towards the middle of the basket if possible to facilitate washing.
- ▶ Make sure that the items do not block the washing arms and that the arms can turn freely.
- ▶ Distribute the load evenly across the baskets.
- ▶ The mobile units, baskets, modules and inserts holding the load must be used only as intended.
- ▶ Empty any containers or utensils before loading them.
- ▶ Take apart any items that can be dismantled in accordance with the manufacturer's instructions, and process the individual parts separately from each other.
- ▶ Do not place items to be cleaned inside other items where they may be concealed. Do not place items so close together that cleaning is hampered.
- ▶ Arrange the load so that the water can access all surfaces.
- ▶ Small items and micro components must only be processed in special inserts, mesh trays with lids or mesh inserts.
- ▶ Plastic items must be thermally resistant.



Injector connections that are not in use must be closed using the caps provided. New caps are available from Miele.



The maximum load permitted for lower level is 25 kg.
The maximum load permitted for additional upper levels is 15 kg.
Never operate the machine without a load carrier in place.

Before starting to use the machine, make sure that all the routine maintenance tasks have been carried out. Check the washing arm rotation.

The list below provides examples of load carriers and inserts which may be used when reprocessing laboratory glassware and utensils:

Other components are available from Miele.

5.6 Adjusting the upper basket

Height-adjustable upper baskets can be adjusted between three positions, 2 cm apart, to accommodate items of different heights.

To adjust the height, the brackets with rollers on the side of the upper basket and the water connector at the back of the basket need to be moved. The roller brackets are each secured to the upper basket by two screws. The water connector consists of the following components:

- ▶ A stainless steel plate with 2 apertures
- ▶ a plastic connection piece
- ▶ 6 screws



The upper basket must only be horizontally adjusted. The baskets are not designed to be positioned on a slant (one side up, one side down).

Altering the height will alter the loading heights for both the upper and lower baskets.

To adjust the upper basket:

- ▶ Remove the upper basket by pulling it out until a resistance is felt, then lift it off the runners
- ▶ Unscrew the roller brackets and the water connector

5.6.1 Adjusting to the lower position

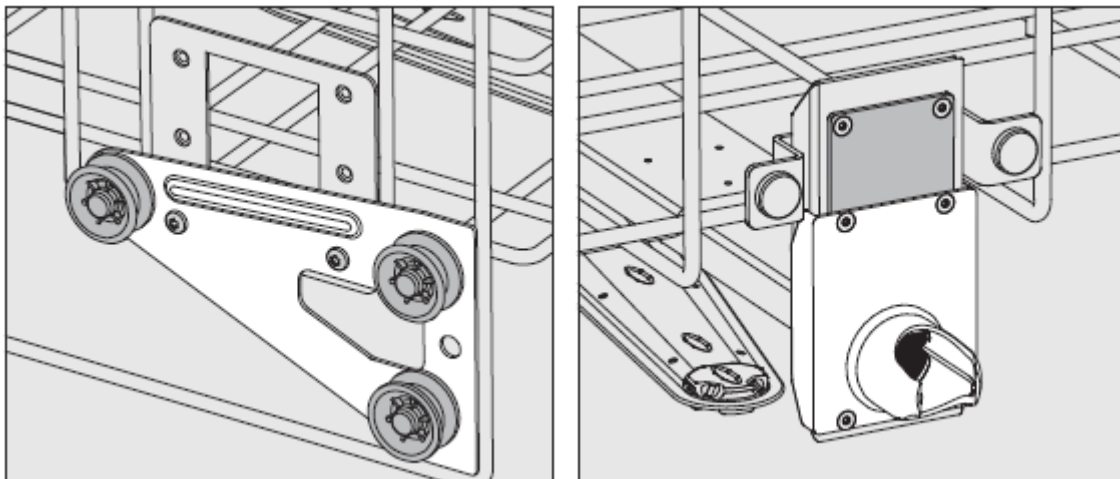

- ▶ Move the roller brackets on both sides to the lower position and secure them firmly.
- ▶ Position the stainless steel plate over the openings in the water supply pipe so that the upper aperture is covered. Secure the stainless steel plate at the top with 2 screws. Place the water connector in the lower aperture of the stainless steel plate so that the middle aperture is covered. Secure the water connector with 4 screws.

5.6.2 Adjusting to the middle position

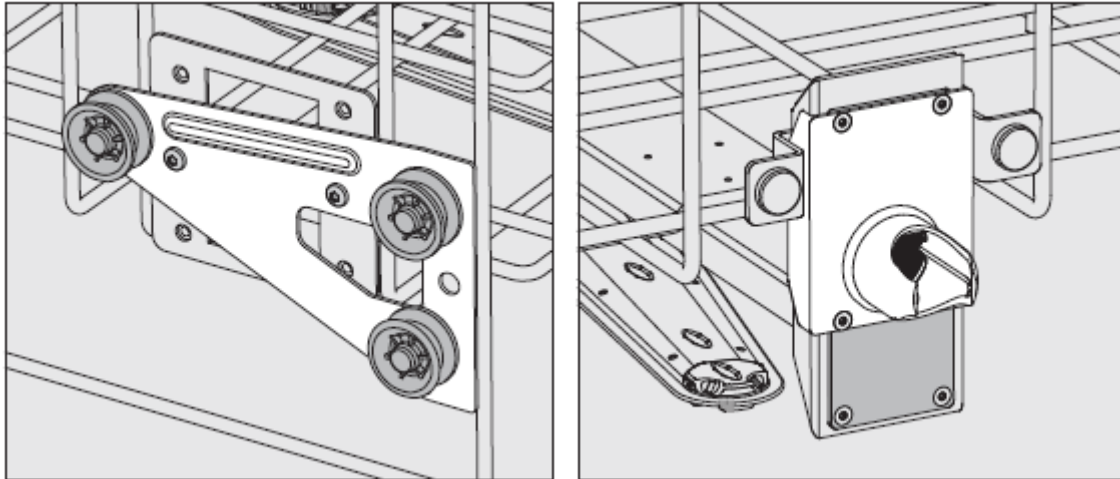

- ▶ Move the roller brackets on both sides to the middle position and secure them firmly.
- ▶ Position the stainless steel plate over the openings in the water supply pipe so that one of the outer apertures is covered. Secure the stainless steel plate at the top or bottom with 2 screws. Place the water connector in the middle aperture of the stainless steel plate so that the outer aperture is covered. Secure the water connector with 4 screws.

5.6.3 Adjusting to the upper position

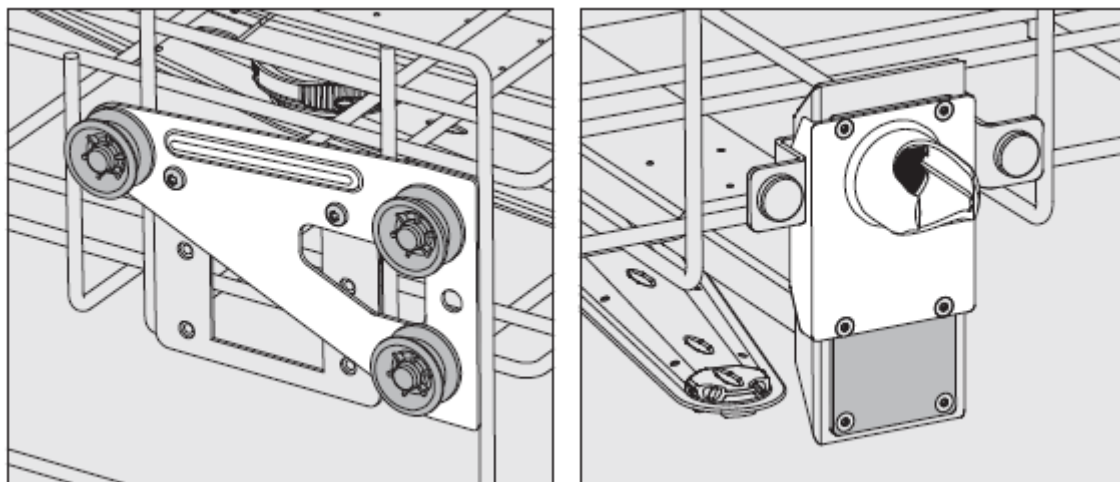

- ▶ Move the roller brackets on both sides to the top position and secure them firmly.
- ▶ Position the stainless steel plate over the openings in the water supply pipe so that the lower aperture is covered. Secure the stainless steel plate at the bottom with 2 screws. Place the water connector in the upper aperture of the stainless steel plate so that the middle aperture is covered. Secure the water connector with 4 screws.

5.7 SmartLoad Plus

To reduce consumption and the cycle run time, the machine is equipped with 4 sensors to detect how many load carriers are loaded into the machine. Depending on the number of load carriers placed in the machine, the latter automatically suggests the most efficient program. This smart system reduces resources and the cycle run time to a minimum.

5.8 Checks after a program

- ▶ Visually check the load for cleanliness.



Any items that have been disconnected during reprocessing or which are found not to be sufficiently cleaned, must be reprocessed again

6. CHEMICAL PRODUCT TANK REPLACEMENT

Replace an empty tank as follows:

- ▶ Have a new tank with process chemicals ready.
- ▶ Open the door in the plinth of the machine.
- ▶ Remove the siphon and place it on a chemical-resistant and easy-to-clean surface.
- ▶ Insert the siphon into the new tank.
- ▶ Place the tank in the plinth of the machine.
- ▶ Close the door in the plinth.
- ▶ Start the appropriate program to vent the DOS pump.

ATTENTION



- ▶ The chemical that is used can be dangerous if touched or inhaled.
- ▶ Stock the chemical products following the instructions in the safety data sheets.
- ▶ Only use process chemicals specifically designed for use in the machine and follow the chemical manufacturer's instructions.
- ▶ Take care when using process chemicals. Some agents may be corrosive and irritating. The relevant safety regulations and safety data sheets issued by the process chemical manufacturers must be observed. Wear protective gloves and goggles.
- ▶ The chemical compartment in the plinth of the machine is accessed using a key. The compartment may only be accessed by authorised personnel.

6.1 Recommendation

Use only chemical products that are appropriate for the reprocessed load and the machine. The manufacturer recommends the products indicated in the table below for good compatibility of the material with the device. In case of uncertainty, please contact the manufacturer of the load, process chemicals or machine.

Each chemical dispensing system is combined with a label that identifies the number of the dispenser. Depending on the type of chemicals used, a coloured tube and its cap are installed.

As the pre-set cycles in the machine refer to a dedicated dosing system (DOS 1-4) of the recommended chemicals, it is necessary to check the correspondence of the cycles (ref. Chapter 7) with the chemicals selected by the user.

Make sure that each specific chemical tank matches the correct dosing system (DOS 1-4).

ATTENTION



If chemicals are used other than those recommended, check that the set dosage corresponds with the indicated dosage in the technical data sheets of the products used for each cycle, and modify it if necessary.

The colours used to identify the chemicals are as follows:





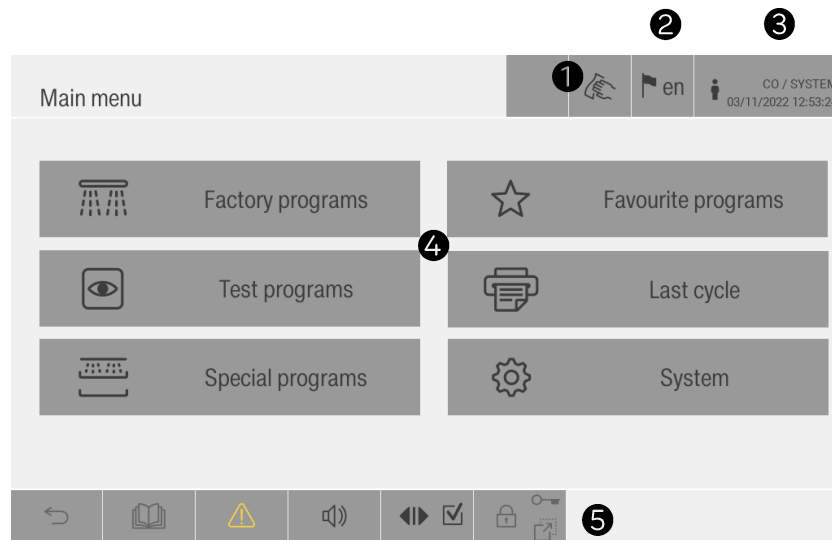

DOS 1	BLUE	Installed ex-factory. Alkaline, enzymatic, or neutral detergent	e.g. - Miele ProCare Lab 10 AP - Miele ProCare Lab 10 AT - Miele ProCare Lab 10 MA
DOS 2		Optional pump (Retrofit Kit)	
DOS 3	RED	Installed ex-factory. Neutralising agent or acid detergent	e.g. - Miele ProCare Lab 30 C - Miele ProCare Lab 30 P
DOS 4		Optional pump (Retrofit Kit)	

7. CONTROL PANEL

7.1 Control panel¹











- ① Header
- ② Display language selection
- ③ Current user
- ④ Buttons to call up sub-menu
 - Cycle selection
 - Last cycle information menu
 - Settings menu
- ⑤ Footer



Symbols	Button Description / Function
 Factory program	Opens the list of ex-factory programs
 Test program	Opens the list of test programs
 Special program	Opens the list of special or customised programs
 Favourite programs	Opens the list of programs saved as favourites, choose between Factory and Special programs
 Last cycle	Opens a sub-menu with all the information about the last cycle run
 System	Opens a sub-menu with the settings, adjustment and utility functions

















¹ The screens shown in this manual have been modified with a light grey colour for improved printing and visualisation of the document

7.1.1 Symbols on the header

BUTTON	DESCRIPTION
	Cycle running (GREEN)
	Cycle in alarm (RED)
	The current program has been interrupted, so the cycle needs to be repeated (YELLOW)
 END	Program completed successfully (GREEN)
 END	Program ended, but there was a program interruption (YELLOW)
 END	Program not completed successfully (RED)
	If manual mode is activated, the symbol is displayed at the top of the control panel (YELLOW)
	Regeneration active (YELLOW)
	Display cleaning button (Freezes the display for 30s to allow display cleaning)

7.1.2 Symbols on the footer

BUTTON	DESCRIPTION
	Backward button
	Main menu button
	Alarms active icon

	Warnings active icon
	Acoustic signal enabled
	Acoustic signal disabled
	Open door. Only closure is possible.
	Closed door. Only opening is possible.
	Door not closed. It is possible to open and close the door.
	Door locked.
	Door opening (yellow flashing).
	Door closing (yellow flashing).
	Door enabled.
	Door disabled because the unloading door is enabled.
	
	Door disabled due to program running.
	
	Door disabled due to alarm.
	
	Door locked due to high chamber temperature

7.1.3 Keyboards

There are 2 available types of keyboards used to enter data, numbers, alphanumeric data and passwords.

Numeric keyboard

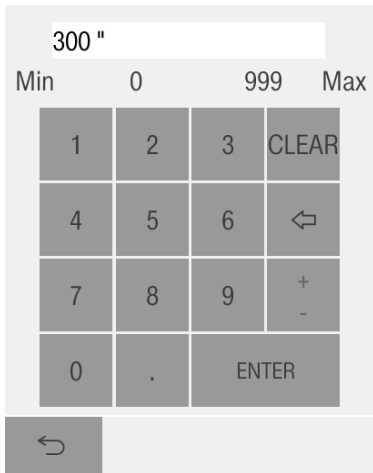

Alphanumeric and password input keyboard

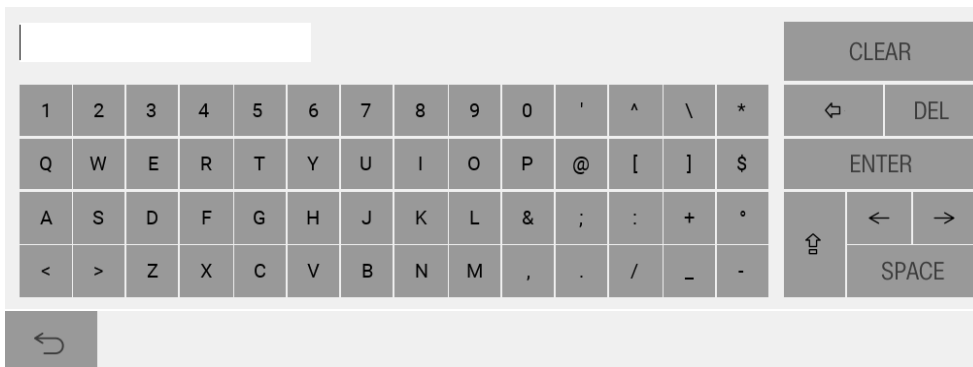

8. CYCLE MANAGEMENT

8.1 Operator login

The operator must log in to be able to execute every operation on the control panel. Depending on the operator's level of authorisation, elements of the menu may be hidden.

To log in, press the  icon in the header.

If another operator is already logged in, the LOGOUT button must be pressed.

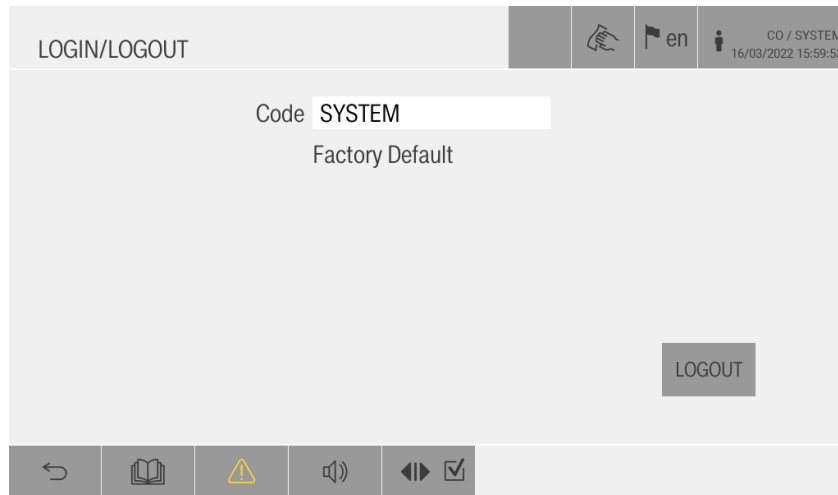

When the icon is pressed again, the following page will appear:

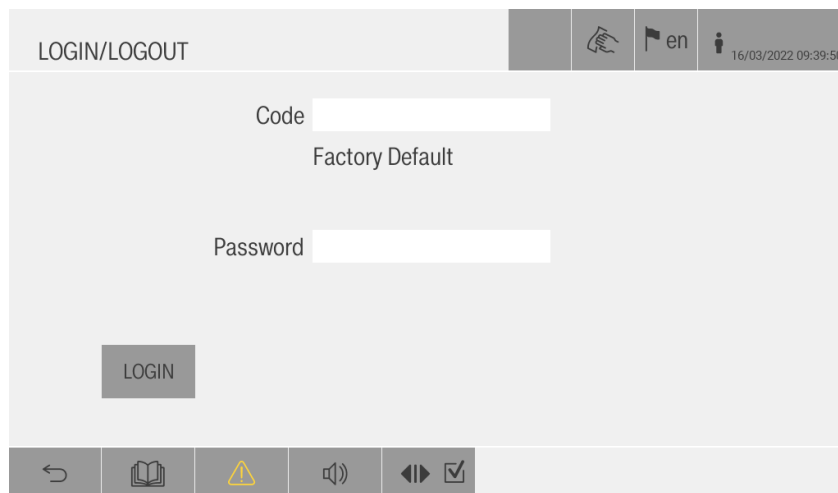

Insert the code and the password, then press LOGIN.

The operator code will appear at the top right of the control panel over the date and time.



ATTENTION

When an operator logs in for the first time, a password change is requested.
After the password change it will be necessary to LOG IN again.

8.2 Change language

To change the language, press the language icon  in the header and the following screen will appear.

The language can be selected and confirmed using the  key.

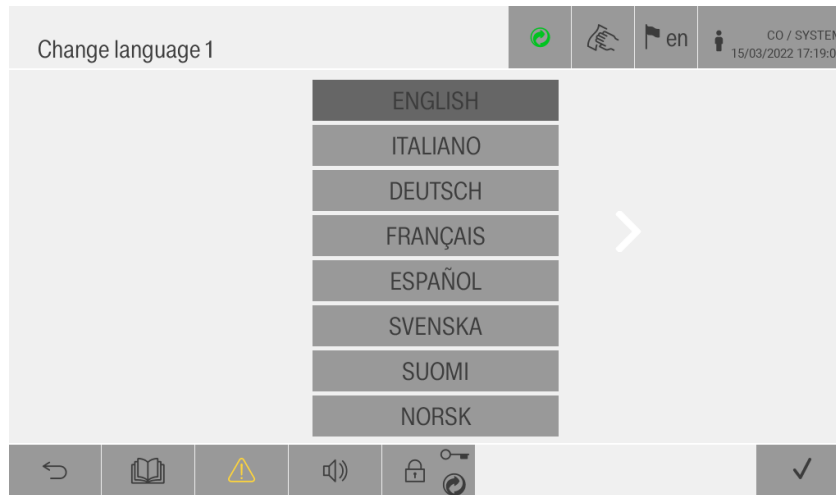

8.3 Cycle start

The start of a cycle can be set in two ways:

- ▶ Manually selecting the cycle
- ▶ Using the LEVEL recognition

This setting can only be made by a trained technician with supervisor access.

8.3.1 Cycle start: standard version

If the parameter for the AUTOMATIC CYCLE START is set to NO (SYSTEM → SETTING → WORK 3) With the machine ON, the main menu appears, and the cycle menu must be selected, choosing between FACTORY PROGRAMS, FAVOURITE PROGRAMS and SPECIAL PROGRAMS.

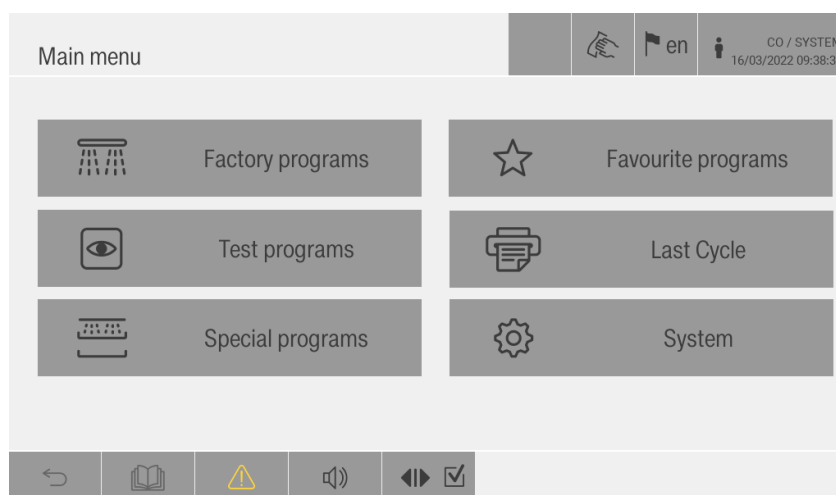

Select the cycle to be run from the list



Then press the START button at the bottom of the screen **twice**

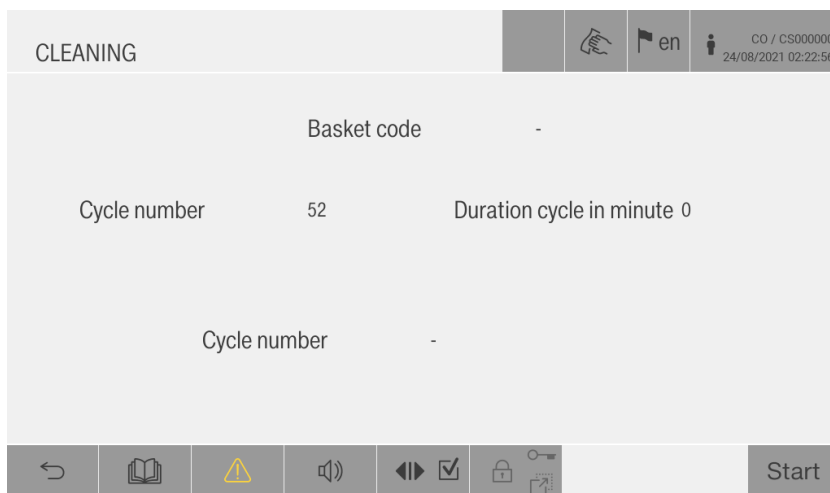

8.3.2 Cycle start: automatic version

If the parameter for the AUTOMATIC CYCLE START is set to YES (SYSTEM → SETTING → WORK 3)
The procedure is the same as in the previous section.

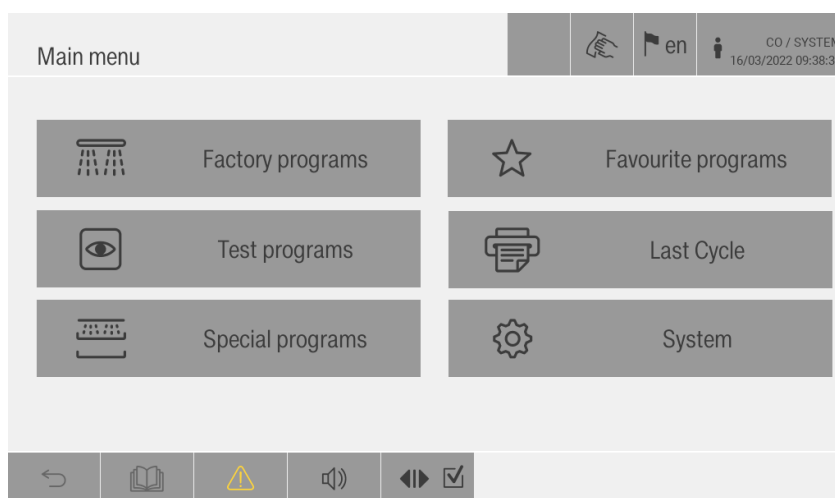

Select the cycle to be run and the cycle will automatically start.

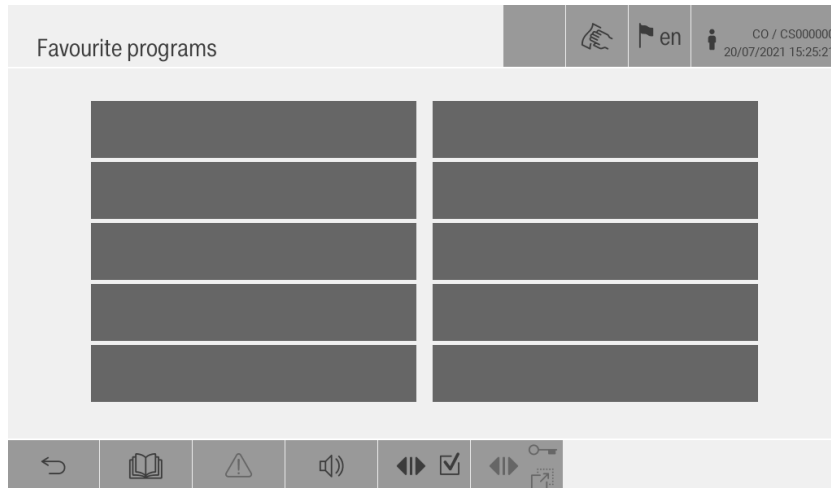

8.4 Reset procedure

In the event of an alarm, a red X appears at the bottom of the control panel.

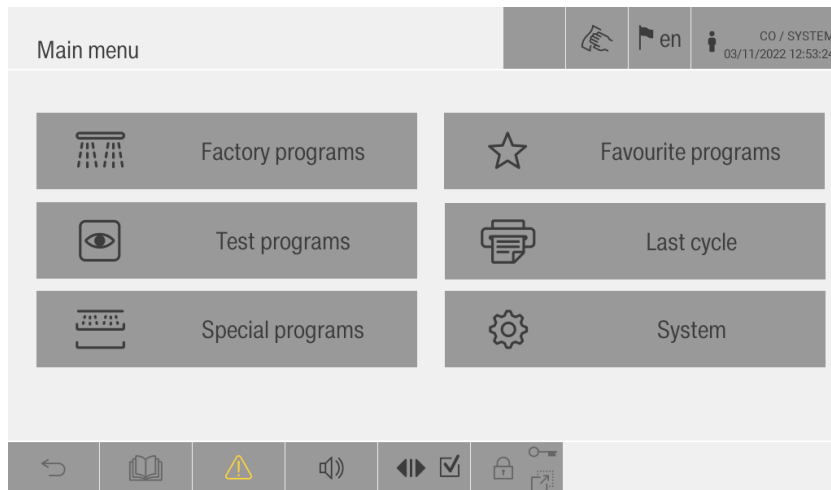

Press the red X and a screen with the alarm code will be displayed.



Solve the problem and press the RESET button. The machine resumes the cycle or goes into stand-by mode.

8.5 Alerts

In the event of a warning, a yellow triangle  appears on the footer of the control panel.

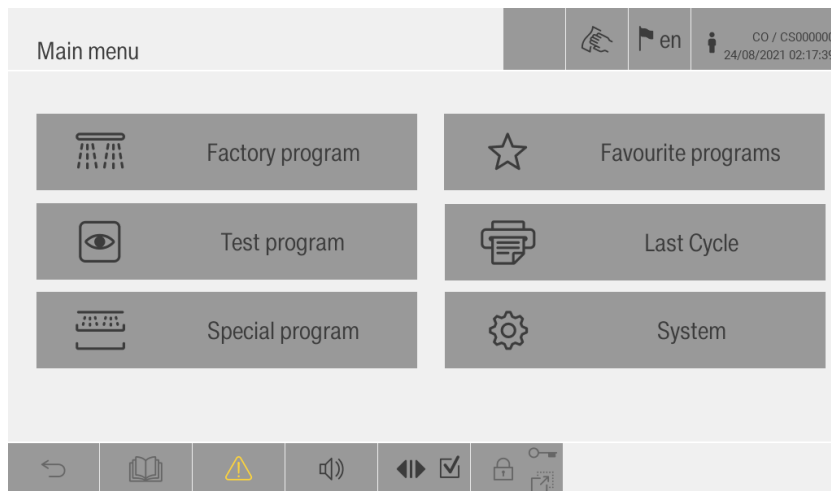

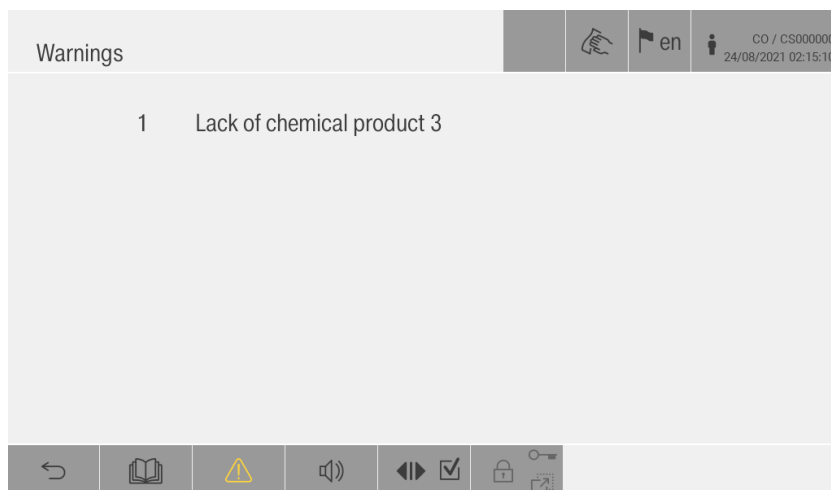

Press the yellow triangle and a screen with the warning code will be displayed.

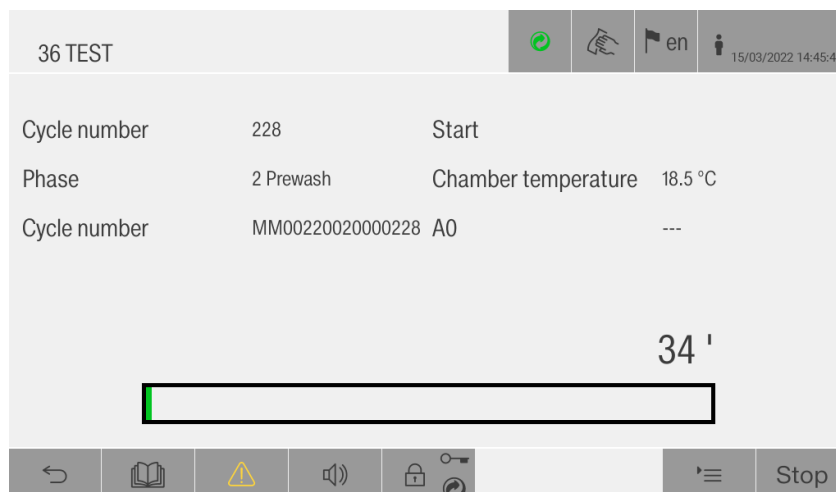

8.6 Cycle screens

During the washing cycle, various information can be viewed. The main page after the start of the cycle is the following:



By pressing the  button on the footer of the control panel, the view can be changed and other information can be seen

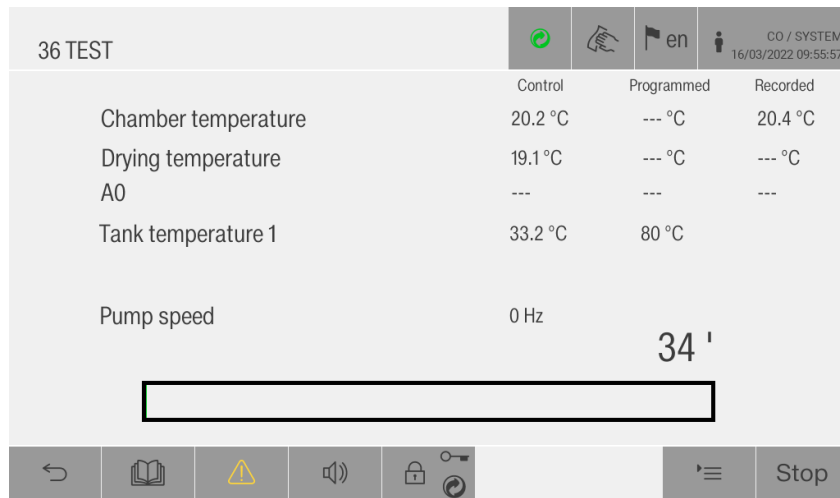

36 TEST CO / SYSTEM
16/03/2022 09:55:57

	Control	Programmed	Recorded
Chamber temperature	20.2 °C	--- °C	20.4 °C
Drying temperature	19.1 °C	--- °C	--- °C
A0	---	---	---
Tank temperature 1	33.2 °C	80 °C	
Pump speed	0 Hz		

34'

Stop

Second page: temperature information and remaining time

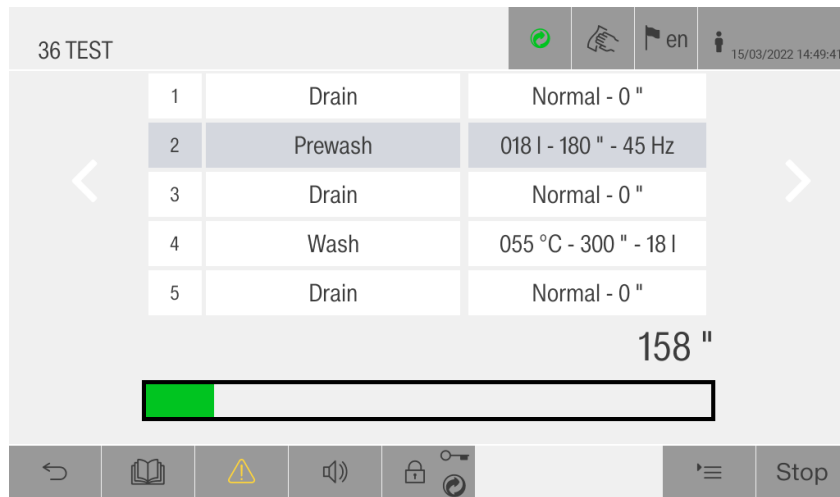

36 TEST CO / SYSTEM
15/03/2022 14:49:41

1	Drain	Normal - 0"
2	Prewash	018 l - 180" - 45 Hz
3	Drain	Normal - 0"
4	Wash	055 °C - 300" - 18 l
5	Drain	Normal - 0"

158"

Stop

Third page: cycle information and remaining time of the running phase

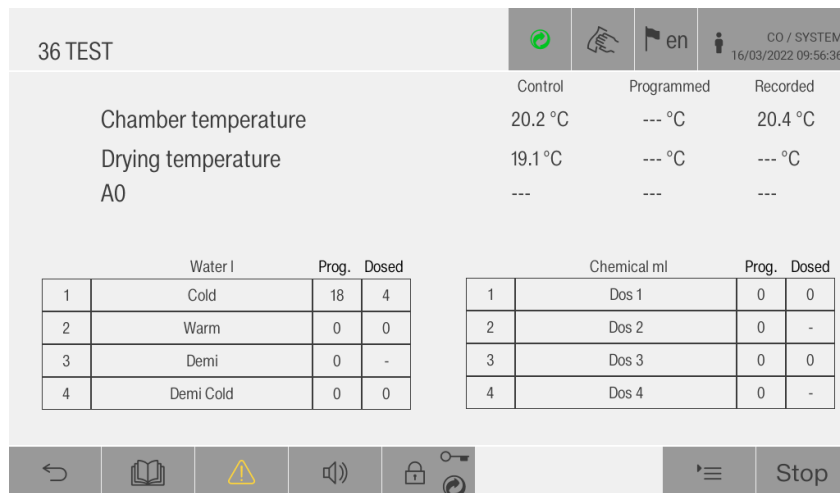

36 TEST CO / SYSTEM
16/03/2022 09:56:36

	Control	Programmed	Recorded
Chamber temperature	20.2 °C	--- °C	20.4 °C
Drying temperature	19.1 °C	--- °C	--- °C
A0	---	---	---

Water l		Prog.	Dosed	Chemical ml		Prog.	Dosed
1	Cold	18	4	1	Dos 1	0	0
2	Warm	0	0	2	Dos 2	0	-
3	Demi	0	-	3	Dos 3	0	0
4	Demi Cold	0	0	4	Dos 4	0	-

Stop

Fourth page: consumption data and temperature information

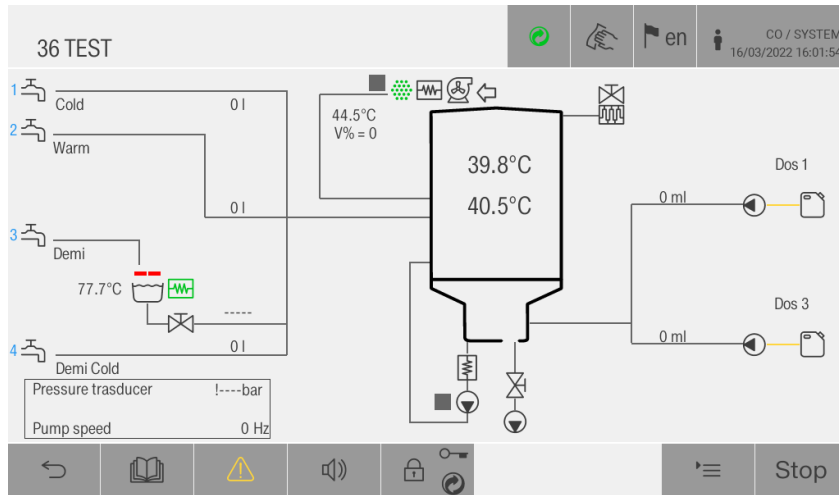

Fifth page: synoptic

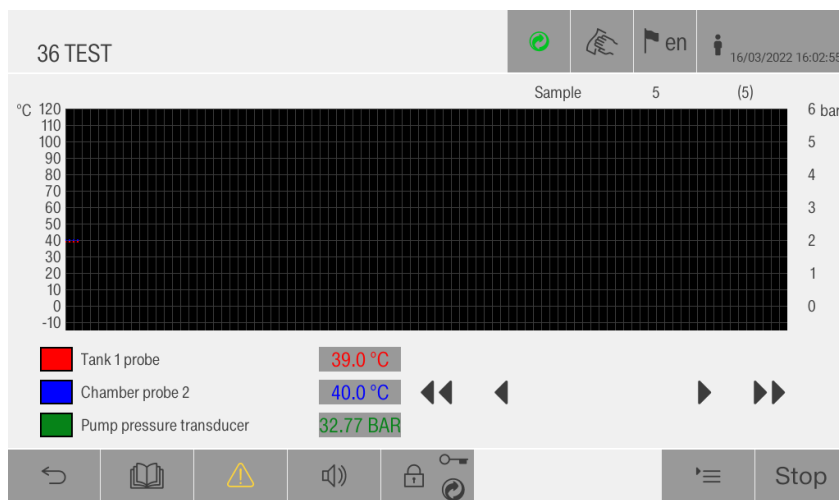

Sixth page: sensors trend

9. WASHING PROGRAMS

The machine in your possession can be used with various washing programs depending on requirements; in particular, the following options are available:

Program	Use
Mini	Fast cycle for glassware with low level of dirt
Mini Plus	Fast cycle for glassware with low level of dirt with 2 load levels or more
Standard	Cycle for glassware with medium level of dirt
Standard Plus	Cycle for glassware with medium level of dirt with 2 load levels or more
Universal	Cycle for all type of load
Universal Plus	Cycle for all type of load with 2 load levels or more
Intensive	Cycle for glassware with high level of dirt
Intensive Plus	Cycle for glassware with high level of dirt with 2 load levels or more
Inorganic	Cycle for glassware with inorganic dirt
Inorganic Plus	Cycle for glassware with inorganic dirt with 2 load levels or more
Organic	Cycle for glassware with organic dirt
Organic Plus	Cycle for glassware with organic dirt with 2 load levels or more
Oil	Cycle for glassware with oil residues
Oil Plus	Cycle for glassware with oil residues with 2 load levels or more
Agar	Cycle for glassware with agar residues
Agar Plus	Cycle for glassware with agar residues with 2 load levels or more
Plastic	Cycle for plastic objects
Plastic Plus	Cycle for plastic objects with 2 load levels or more
Vials	Cycle for vials
Vials Plus	Cycle for vials with 2 load levels or more
Hygen 90/10	Cycle for thermal disinfection treatment
Hygen 90/10 Plus	Cycle for thermal disinfection treatment with 2 load levels or more
Pipettes	Cycle for pipettes
Cold water rinse	Rinse using cold water
Demin. Water rinse	Rinse using demineralised water
Drain	Drain cycle
Drying	Drying cycle

Empty tank	Cycle for tank draining and water renew
Fill DOS 1	Cycle to fill the dosing circuit for chemical product 1
Fill DOS 2	Cycle to fill the dosing circuit for chemical product 2
Fill DOS 3	Cycle to fill the dosing circuit for chemical product 3
Fill DOS 4	Cycle to fill the dosing circuit for chemical product 4

9.1 Program blocks

- ▶ **Drain:** drains water from the chamber
- ▶ **Prewashing:** the prewashing is used to remove coarse dirt and foaming substances.
- ▶ **Washing:** depending on the load, washing usually occurs at temperatures of 45°C - 93°C, adding the necessary detergent (chemicals)
- ▶ **Rinse:**
 - Intermediate rinse: rinse-off and neutralisation of process chemicals from the previous phases
 - Final rinse: demineralised water should preferably be used, if available, to avoid deposits on the load and to reduce process chemical residue.
- ▶ **Drying:** sufficient drying reduces the risk of corrosion caused by residual moisture on the load.
- ▶ **Tank disinfection:** used in special cycles for the periodical disinfection of the tanks and chamber to avoid bioburden growth on the surfaces of the tanks and chamber, such as hydraulic circuits

9.2 Program overview

N.	Program name	Prewashing / Washing	Main washing	Washing	Washing / Rinse	Rinse	Final rinse	Drying
1	Mini			WW 18L DOS1 0.3% 180" 60°C 50Hz		CW 16L DOS3 0.1% 120" 45Hz	DW 16L 60" 60°C 45Hz	150" LS 2100" HS 120" SC 120°C
2	Mini Plus			WW 21L DOS1 0.3% 180" 60°C 55Hz		CW 19L DOS3 0.1% 120" 50Hz	CDW DW 19L 60" 60°C 50Hz	150" LS 2400" HS 120" SC 120°C
3	Standard			CW WW 18L DOS1 0.4% 180" 70°C 50Hz	WW 16L DOS3 0.1% 120" 45Hz	CW CDW 16L 60" 45Hz	DW 16L 60" 70°C 45Hz	150" LS 2100" HS 120" SC 120°C
4	Standard Plus			CW WW 21L DOS1 0.4% 180" 70°C 55Hz	WW 19L DOS3 0.1% 120" 50Hz	CW CDW 19L 60" 50Hz	CDW DW 19L 60" 70°C 50Hz	150" LS 2400" HS 120" SC 120°C
5	Universal	CW WW 16L 60" 45Hz		WW 18L DOS1 0.3% 180" 75°C 50Hz	WW 16L DOS3 0.1% 120" 45Hz	CDW 16L 60" 45Hz	DW 16L 60" 75°C 45Hz	150" LS 2100" HS 120" SC 120°C
6	Universal Plus	CW WW 19L 60" 50Hz		WW 21L DOS1 0.3% 180" 75°C 55Hz	WW 19L DOS3 0.1% 120" 50Hz	CDW 19L 60" 50Hz	CDW DW 19L 60" 75°C 50Hz	150" LS 2400" HS 120" SC 120°C
7	Intensive	CW WW 16L 60" 45Hz	WW 18L DOS1 0.4% 180" 80°C 50Hz	WW 16L DOS3 0.1% 120" 45Hz	CDW 16L 60" 45Hz	CDW 16L 60" 45Hz	DW 16L 60" 75°C 45Hz	150" LS 2100" HS 120" SC 120°C
8	Intensive Plus	CW WW 19L 60" 50Hz	WW 21L DOS1 0.4% 180" 80°C 55Hz	WW 19L DOS3 0.1% 120" 50Hz	CDW 19L 60" 50Hz	CDW 19L 60" 50Hz	DCW DW 19L 60" 75°C 50Hz	150" LS 2400" HS 120" SC 120°C
9	Inorganic	CW WW 16L DOS3 0.3% 120" 50°C 50Hz	WW 18L DOS1 0.4% 180" 75°C 50Hz	WW 16L DOS3 0.1% 120" 45Hz	CDW 16L 60" 45Hz	CDW 16L 60" 45Hz	DW 16L 60" 70°C 45Hz	150" LS 2100" HS 120" SC 120°C
10	Inorganic Plus	CW WW 21L DOS3 0.3% 120" 55°C 50Hz	WW 21L DOS1 0.4% 180" 75°C 55Hz	WW 19L DOS3 0.1% 120" 50Hz	CDW 19L 60" 50Hz	CDW 19L 60" 50Hz	DCW DW 19L 60" 70°C 50Hz	150" LS 2400" HS 120" SC 120°C
11	Organic		WW 18L DOS1 0.4% 120" 65°C 50Hz	WW 18L DOS1 0.3% 180" 85°C 50Hz	WW 16L DOS3 0.1% 120" 45Hz	CDW 16L 60" 45Hz	DW 16L 60" 75°C 45Hz	150" LS 2100" HS 120" SC 120°C
12	Organic Plus		WW 21L DOS1 0.4% 120" 65°C 55Hz	WW 21L DOS1 0.3% 180" 85°C 55Hz	WW 19L DOS3 0.1% 120" 50Hz	CDW 19L 60" 50Hz	CDW DW 19L 60" 75°C 50Hz	150" LS 2100" HS 120" SC 120°C
13	Oil	CW WW 18L DOS4 0.4% DOS1 0.4% 60" 45°C 50Hz	WW 18L DOS4 0.4% DOS1 0.4% 120" 65°C 50Hz	WW 18L DOS1 0.3% 180" 85°C 50Hz	WW 16L DOS3 0.1% 120" 45Hz	CDW 16L 60" 45Hz	DW 16L 60" 75°C 45Hz	150" LS 2100" HS 120" SC 120°C
14	Oil Plus	CW WW 21L	WW 21L	WW 21L	WW 19L	CDW 19L	DW 19L	150" LS

		DOS4 0.4% DOS1 0.4% 60" 45°C 55Hz	DOS4 0.4% DOS1 0.4% 120" 65°C 55Hz	DOS1 0.3% 180" 85°C 55Hz	DOS3 0.1% 120" 50Hz	60" 50Hz	60" 75°C 50Hz	2400" HS 120" SC 120°C
15	Agar		WW 18L 240" 90°C 50Hz	WW 18L DOS1 0.3% 180" 75°C 50Hz	WW 16L DOS3 0.1% 120" 45Hz	CDW 16L 60" 45Hz	DW 16L 60" 75°C 45Hz	150" LS 2100" HS 120" SC 120°C
16	Agar Plus		WW 21L 240" 90°C 55Hz	WW 21L DOS1 0.3% 180" 75°C 55Hz	WW 19L DOS3 0.1% 120" 50Hz	CDW 19L 60" 50Hz	DW 19L 60" 75°C 50Hz	150" LS 2400" HS 120" SC 120°C
17	Plastic	CW WW 16L 60" 45Hz	CW WW 18L DOS1 0.3% 300" 55°C 50Hz	CW WW 16L DOS3 0.1% 120" 45Hz		CDW 16L 60" 45Hz	DW 16L 60" 55°C 45Hz	90" LS 2700" HS 60" SC 90°C
18	Plastic Plus	CW WW 19L 60" 50Hz	CW WW 21L DOS1 0.3% 300" 55°C 55Hz	CW WW 19L DOS3 0.1% 120" 50Hz		CDW 19L 60" 50Hz	CDW DW 19L 60" 55°C 50Hz	90" LS 3000" HS 60" SC 90°C
19	Vials	CW WW 22L 60" 45Hz	WW 22L DOS1 0.3% 180" 75°C 50Hz	WW 22L DOS3 0.1% 120" 50Hz	CDW 22L 60" 50Hz	CDW 22L 60" 50Hz	CDW DW 22L 60" 75°C 50Hz	150" LS 2700" HS 120" SC 120°C
20	Vials Plus	CW WW 26L 60" 50Hz	WW 26L DOS1 0.3% 180" 75°C 55Hz	WW 26L DOS3 0.1% 120" 55Hz	CDW 26L 60" 55Hz	CDW 26L 60" 55Hz	CDW DW 26L 60" 75°C 55Hz	150" LS 3000" HS 120" SC 120°C
21	Hygen 90/10		CW WW 18L DOS1 0.3% 600" 90°C 50Hz	WW 16L DOS3 0.1% 120" 45Hz		CW CDW 16L 60" 45Hz	DW 16L 60" 75°C 45Hz	150" LS 2100" HS 120" SC 120°C
22	Hygen 90/10 Plus		CW WW 21L DOS1 0.3% 600" 90°C 55Hz	WW 19L DOS3 0.1% 120" 50Hz		CW CDW 19L 60" 50Hz	CDW DW 19L 60" 75°C 50Hz	150" LS 2400" HS 120" SC 120°C
23	Pipettes	CW WW 23L 60" 45Hz	WW 21L DOS1 0.4% 180" 70°C 45Hz	WW 21L DOS3 0.1% 120" 45Hz	CDW 21L 60" 45Hz	CDW 21L 60" 45Hz	CDW DW 21L 60" 70°C 45Hz	150" LS 3600" HS 120" SC 90°C
24	Cold water rinse					CW 20L 120" 50Hz		
25	Demin. Water rinse					DW 20L 120" 50Hz		
26	Drain							
27	Drying							90" LS 1800" HS 60" SC 120°C
28	Empty tank					DW 16L 20" 40Hz		
29	Fill DOS 1		WW 12L DOS1 0.5% 20" 35Hz				WW 10L 20" 35Hz	
30	Fill DOS 2		WW 12L DOS2 0.5% 20" 35Hz				WW 10L 20" 35Hz	
31	Fill DOS 3		WW 12L DOS3 0.5% 20" 35Hz				WW 10L 20" 35Hz	

32	Fill DOS 4		WW 12L DOS4 0.5% 20" 35Hz				WW 10L 20" 35Hz	
----	---------------	--	---------------------------------	--	--	--	--------------------	--

CW = cold water
 WW = warm water
 CDW = cold demi water
 DW = demineralised water

LS = low speed time
 HS = high speed time
 SC = time for steam condenser

DOS 1 = detergent
 DOS 2 = optional (retrofit kit required)
 DOS 3 = neutraliser
 DOS 4 = (retrofit kit required)

10. MENU

10.1 Main Menu

The main menu allows access to the settings menu, archives, machine status and cycle selection menu. Depending on the authorisation level of the logged operator, the following menu can be completely or partially accessed.

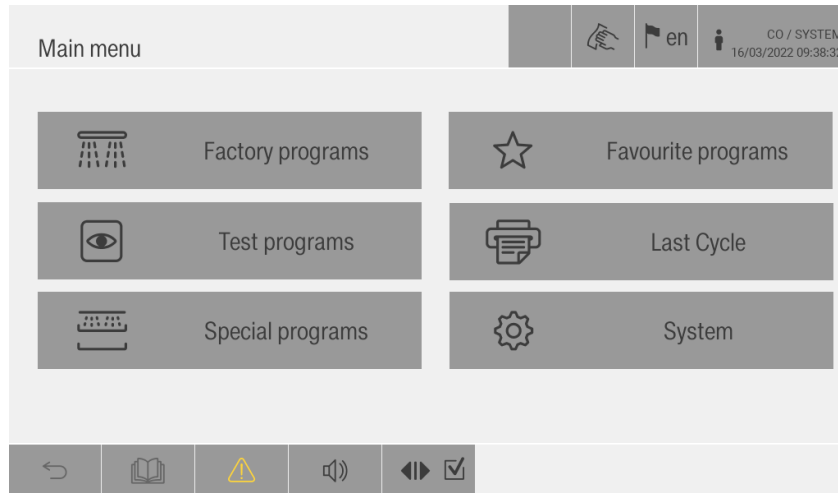

10.2 Factory programs

This menu is dedicated to the selection of the manufacturer programs, to start a washing cycle:



10.3 Special programs

This menu is dedicated to the selection of the customer programs, to start a washing cycle:



10.4 Favourite programs

In this menu it is possible to save the most used programs, to facilitate the operator when selecting the washing cycle:

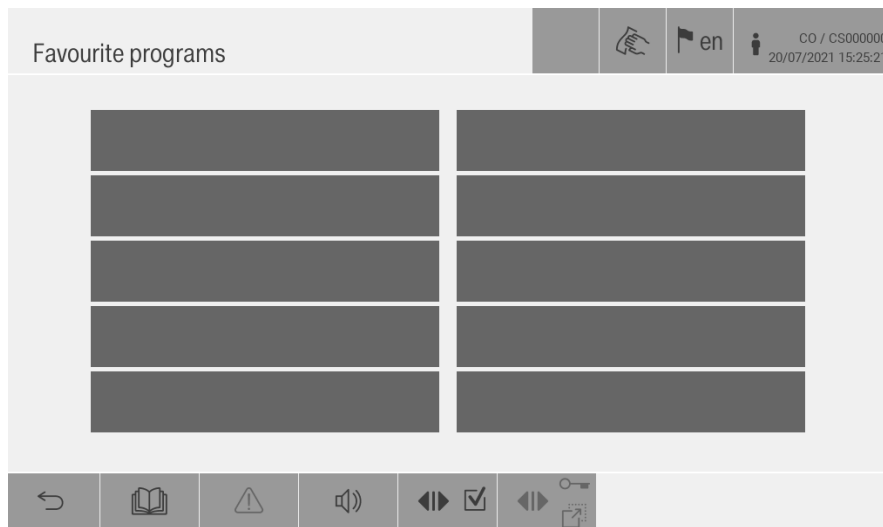

10.5 Last cycle

This page allows viewing the data of the last cycle run.

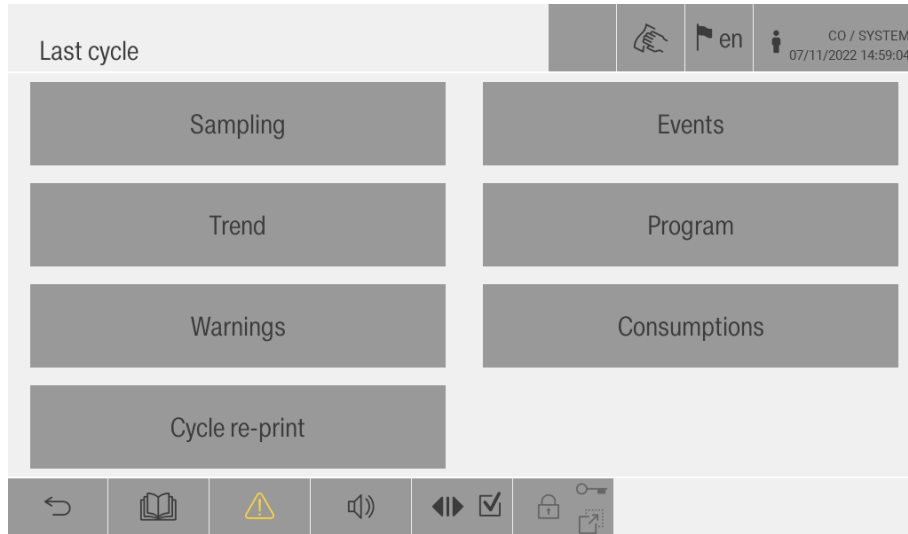

From this page it is possible to open the various dedicated pages to view the samples, events, graph, program specifications, warnings and consumption relative to the last cycle run.

If a printer is installed, it is also possible to reprint the entire report, or the desired data from the various pages.

10.5.1 Sampling

The different pages can be scrolled to view all the temperatures:



10.5.2 Events

The different pages can be scrolled to view all the steps executed during the cycle:

Events

Cycle number MM00210040000288
Operator -
Program 36 EXAMPLE
Start 06/09/2022 14:40:28
End 06/09/2022 15:42:15
Cycle 288 A0 6550

Line 1 (2) Hour 14:40:28 Step ---

Start cycle

Chamber control °C 29.00 Chamber registration °C 29.50

10.5.3 Trend

Displays the sensors trend:

Trend

Cycle number MM00210040000288 Sample 1 (741)

°C 120
110
100
90
80
70
60
50
40
30
20
10
0
-10

Chamber probe 1 29.0 °C
Chamber probe 2 29.0 °C

10.5.4 Program data

Displays the cycle parameters:

Program data				en	CO / SYSTEM 07/09/2022 09:54:16
Cycle number	MM00210040000288				
Operator	-				
Program	36 EXAMPLE				
Start	06/09/2022 14:40:28				
End	06/09/2022 15:42:15				
Cycle	288	A0	6550		
	1	Drain	Normal - 0 "		
	2	Prewash	018 L - 120 " - 50 Hz		
	3	Drain	Normal - 0 "		
	4	Wash	055 °C - 300 " - 20 L		

10.5.5 Warnings

The different pages can be scrolled to view all the warnings and alarms that occurred during the cycle:

Warnings				en	CO / SYSTEM 07/09/2022 09:44:31
Cycle number	MM00210040000288				
Operator	Factory Default				
Program	36 EXAMPLE				
Start	06/09/2022 14:40:28				
End	06/09/2022 15:42:15				
Cycle	288	A0	6550		
Line	0	0	Hour	-	

10.5.6 Consumption

Displays the water and chemical product consumption data for each stage of the cycle:

Consumptions							en	CO / SYSTEM 07/09/2022 09:45:56
Cycle number	MM00210040000288							
Operator	Factory Default							
Program	36 EXAMPLE							
Start	06/09/2022 14:40:28							
End	06/09/2022 15:42:15							
Cycle	288	A0		6550				
Sample	2	(10)	Hour	14:44:30	Step	2 Prewash		
Water (L)				Chemical (mL)				
	Prog.	Dosed			Prog.	Dosed		
1	Cold	18	18	1	Dos 1	0	0	
2	Warm	0	0	2	Dos 2	0	0	
3	Demi	0	0	3	Dos 3	0	0	
4	Demi Cold	0	0	4	Dos 4	0	0	

10.5.7 Cycle re-print

Allows printing of the sampling, cycle setting, and events of the last cycle on a USB or printer:

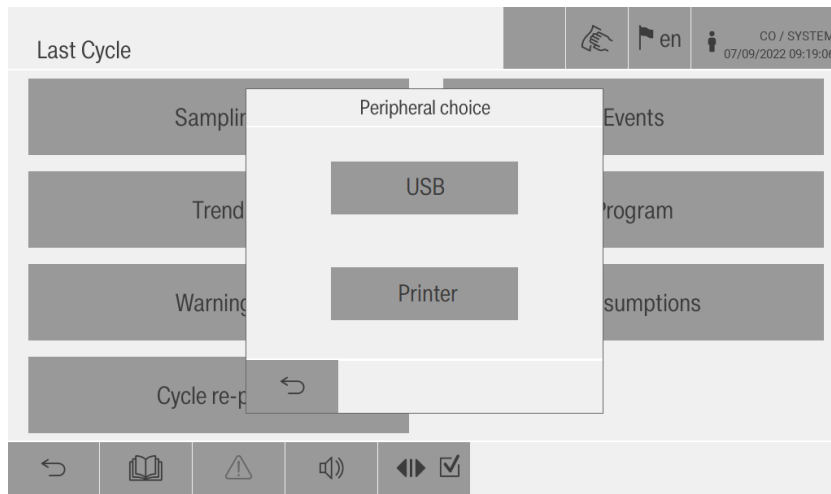

10.6 System

This menu allows access to several other menus:

- ▶ Utility: machine backup and recovery, automatic cycle repetition, machine data, heating selection (in case of mixed heated machines)
- ▶ Archives: storage and settings of program settings
- ▶ Settings: machine set-up
- ▶ Machine status: check and activation of input/output
- ▶ Historical archives: to consult the servicing log, events, cycles, etc.
- ▶ Maintenance: execution of maintenance and adjustment operations

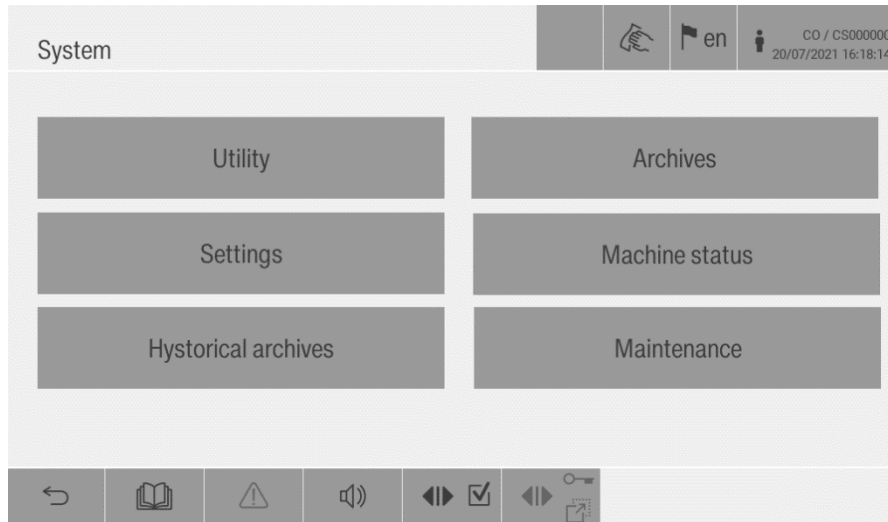

10.6.1 Utility

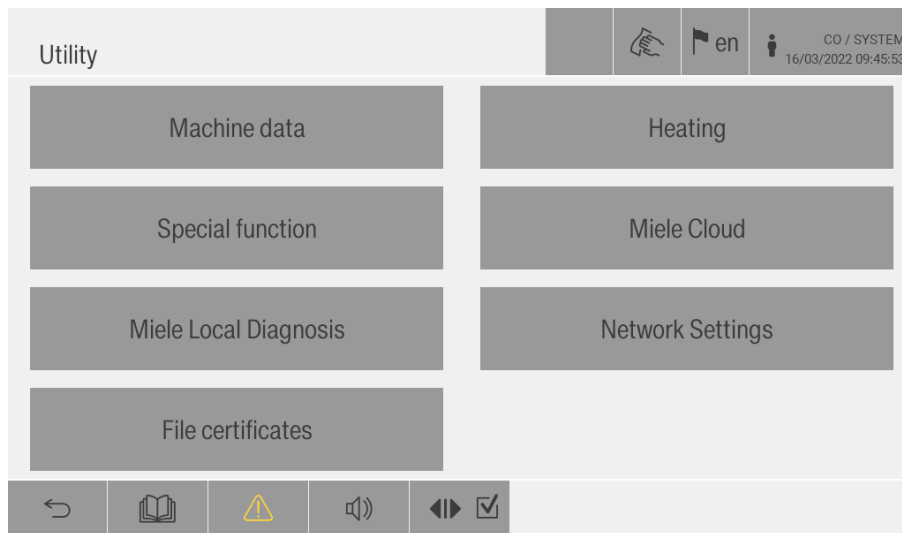

Machine data: to view the main machine data including the name, serial number, test date and user

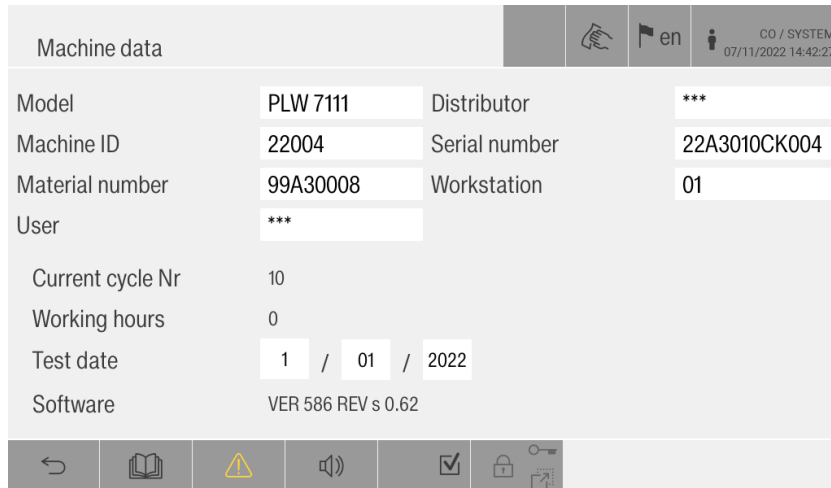

10.6.2 Machine status

In this menu it is possible to check the machine's digital input and output.

If the machine is running a cycle, this menu is hidden.

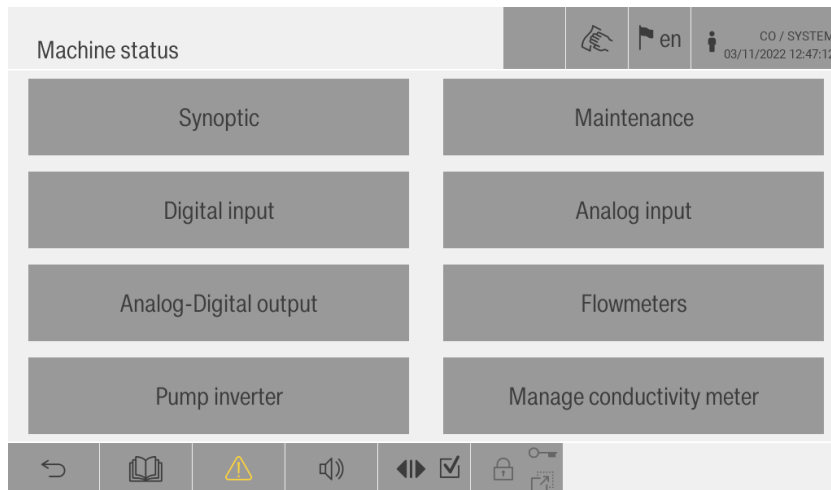



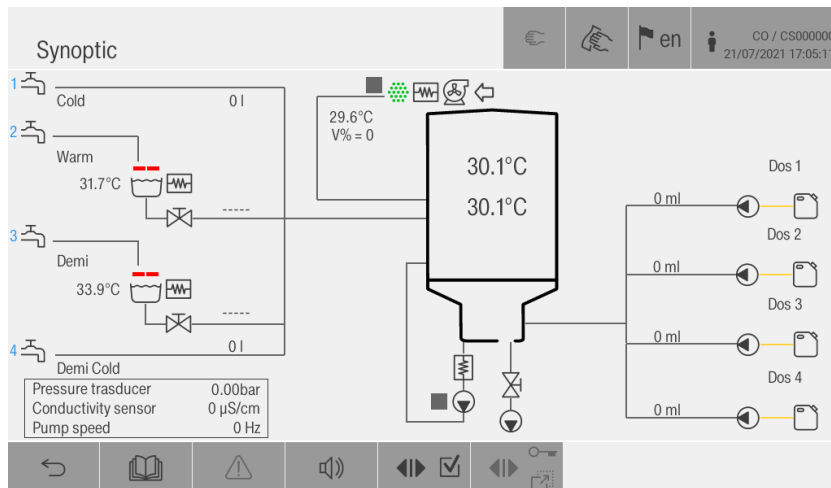















Synoptic: allows checking and activation of the devices directly from the image. The component turns green when active, grey when disabled, and red if in alarm.



Maintenance: displays the maintenance status

Maintenance					
Working hours			00075		
Maintenance type	Description	Last maintenance		Next maintenance	
		Date	Hours	Date	Hours
1	BIANNUAL	09/03/2022	00021	05/09/2022	01021
2	ANNUAL	09/03/2022	00021	09/03/2023	02021
3	EXTRAORDINARY	-	00000	-	00000

Digital input: displays the digital input status

Digital input		
Digital Input		Dip Switch
1.17 Empty chamber switch (N.O.)		1.01 
1.18 Loading door unlocked (N.C.)		1.02 
1.19 Loading door locked (N.C.)		1.03 
1.20 Loading door closed (N.O.)		1.04 
1.21 OK emergency circuit (N.C.)		2.01 
1.22 OK thermal safety (N.O.)		2.02 
1.23 Pump pressure switch (N.O.)		2.03 
1.24 Level 1 tank 1 (N.O.)		2.04 
1.25 Level 2 tank 1 (N.C.)		
1.26 Level 1 tank 2 (N.O.)		



Input ON

Input OFF

Analogue input: displays the status and value measured from the analogue input by the probes and pressure transducers

Analog input		CO / SYSTEM 14/12/2022 11:51:28	
	Probe		
1.30 Chamber probe 1	17.5°C	20 °C	
1.33 Tank 1 probe	18.2°C	20 °C	
1.36 Tank 2 probe	!----°C	20 °C	
2.30 Chamber probe 2	17.7°C		
2.33 Drying probe	16.7°C	20 °C	
2.36-	!----°C		

Analogue-Digital output: displays and allows changes to the digital output status. To activate the digital output, it is sufficient to press on the red square on the right side of the output description.

Analog-Digital output		CO / SYSTEM 14/12/2022 11:52:26	
1.04	Thermal safety intervention		
1.05	Tank 1 drain valve		
1.06	Tank 2 drain valve		
1.07	Tank 1 electrical heating		
1.08	Tank 2 electrical heating		
1.09	Open load door/Door lock mot		
1.10	Close load door		
1.11	Op unload door/Door lock mot		



Output active



Output not active

Flowmeters: displays the status and value measured from the water and chemical flowmeters

Flowmeters		
Flowmeters		
1.J1	Flowmeter product 1	00000 imp
1.J2	Flowmeter product 2	00000 imp
1.J3	Flowmeter product 3	00000 imp
1.J4	Flowmeter product 4	00000 imp
2.J1	Cold water flowmeter	00000 imp
2.J2	Warm water flowmeter	---- imp
2.J3	Demi water flowmeter	---- imp
2.J4	-	00000 imp

Pump inverter: allows manual control of pump activation when the inverter is installed. To activate the pump inverter, the manual control must be activated.



To manually activate the pump inverter, the door must be closed and locked, the chamber must be filled with water and there must be no alarms displayed on the management page below

Pump inverter

Inverter connected

Set pump speed: Hz

Pump speed: 0 Hz

Inverter status: STAND-BY

Conductivity meter: displays the status of the conductivity meter, presence of alarms, and value measured by the probe.

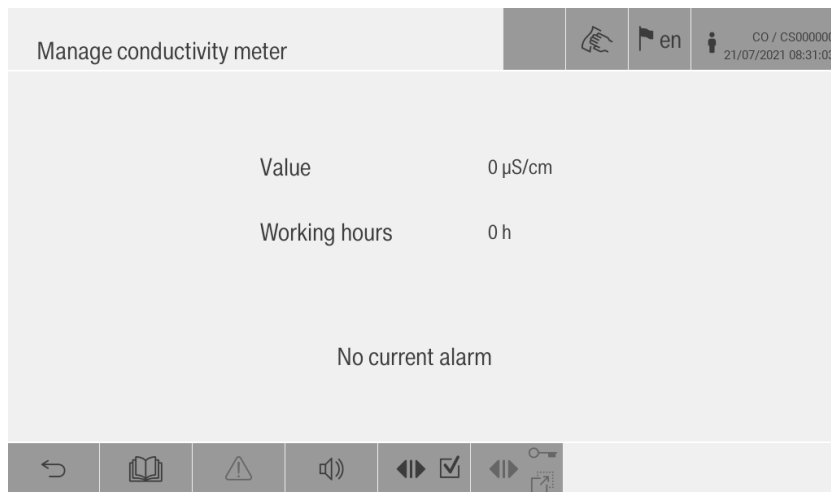

10.6.3 Maintenance

This menu allows the execution and registration of routine maintenance.

	For user level 1 and 2, only the following menus can be accessed:
	<ul style="list-style-type: none">- Clock- Maintenance intervention

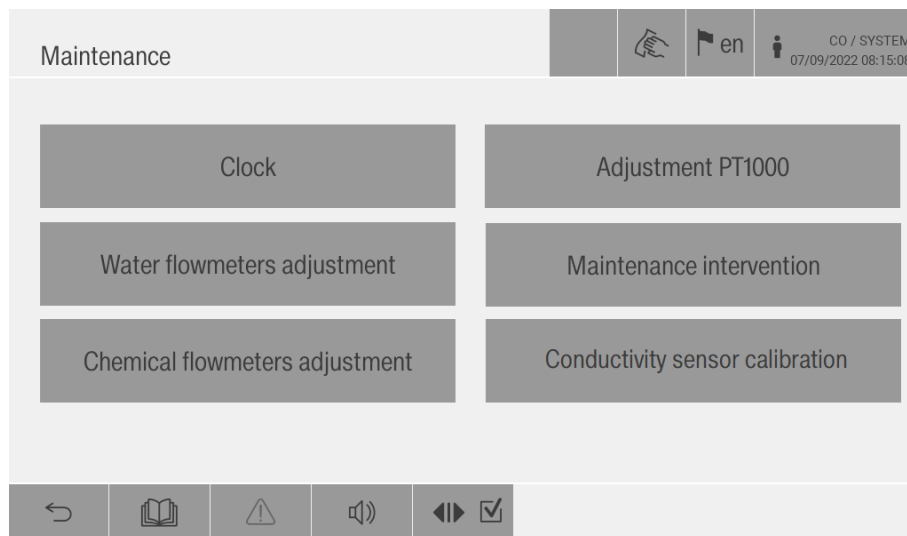

Maintenance intervention: this menu is used to record maintenance interventions

The screenshot shows a mobile application interface for recording maintenance interventions. The title bar at the top reads "MAINTENANCE INTERVENTION" and includes system information like "en" and "CO / SYSTEM 16/03/2022 16:00:47". The main form contains the following fields and values:

- Date intervention: 16/03/2022
- Working hours: 200
- Maintenance type: 1 (selected), BIANNUAL
- Note: A large empty text area for description.
- Total time (hh:mm): Two empty input boxes separated by a colon.
- Next maintenance: 12/09/2022
- Hours: 2200
- Technician: An empty text input field.

At the bottom, there is a navigation bar with icons for back, home, warning, volume, and a confirmation checkmark.

The date is automatically filled based on the clock.

The type of maintenance must be selected (only BIANNUAL can be selected for user level 1 and 2), including a description of the activity carried out.

Then fill in the time required to complete the activity and the name of the technician or operator who performed the maintenance.

The next maintenance interval will be automatically reset.

11. ALARM MESSAGES

11.1 Description of alarms

During operation, every machine error is notified through an alarm message and relative acoustic signal.

An alarm that occurs during machine operation is signalled by a red cross on the control panel and a message.

The alarm remains active until the problem is solved and the message is reset, as explained in the related section.

11.2 List of alarms

Some of the potential alarms can be solved and reset by the operator.

For other alarms, a service technician must intervene.

For safe access to the chamber and technical compartment, please refer to the “Maintenance” section.

The person in charge of alarm resolution is indicated in the following table according to the legend below.

OP: operator

S: service technician

No.	Message displayed	Description	Responsible for alarm resolution
1	Power failure	Signals that the electrical power supply was interrupted during a cycle, once the power is restored	OP
2	Loading door open during cycle	Side loading door opened and/or unlocked during the cycle in progress	S
4	Loading door open & locked	Side loading door is open and locked (inconsistency)	S
7	Loading door locking failure	Triggered in the following possible situations (side loading door): a) the door was not locked within the time defined by the parameter b) the door was opened when it had started locking	S
9	Loading door unlocking failure	The loading door was not unlocked within the time defined by the parameter	S
11	No cold water	The cold water washing chamber supply was not completed (no new water flowmeter pulse for longer than the time defined by the parameter).	S
12	No warm water	The warm water washing chamber supply was not completed (no new water flowmeter pulse for longer than the time defined by the parameter). In the configuration with tank 2 present, it indicates that the water 2 supply in the tank or the water 2 discharge from the tank to the washing chamber was not completed within the maximum time defined by the parameter (level control).	S

13	No demi water	The demineralised water washing chamber supply was not completed (no new water flowmeter pulse for longer than the time defined by the parameter). In the configuration with tank 1 present, it indicates that the water 1 supply in the tank or the water 1 discharge from the tank to the washing chamber was not completed within the maximum time defined by the parameter (level control).	S
17	Chemical DOS1 lack	The product associated with the dosage unit 1 (detergent) is finished (if enabled as an alarm by the parameter). Diagnostics based on (with dosing pump active): - pressure switch disabled if time-based dosage (1.5 s reading delay); - no new pulse for longer than the time defined by the parameter if dosage by flowmeter.	OP
18	Chemical DOS2 lack	The product associated with the dosage unit 2 (neutralising agent) is finished (if enabled as an alarm by the parameter). Diagnostics based on (with dosing pump active): - pressure switch disabled if time-based dosage (1.5 s reading delay); - no new pulse for longer than the time defined by the parameter if dosage by flowmeter.	OP
19	Chemical DOS3 lack	The product associated with the dosage unit 3 (lubricant) is finished (if enabled as an alarm by the parameter). Diagnostics based on (with dosing pump active): - pressure switch disabled if time-based dosage (1.5 s reading delay); - no new pulse for longer than the time defined by the parameter if dosage by flowmeter.	OP
20	Chemical DOS4 lack	The product associated with the dosage unit 4 (soda ash) is finished (if enabled as an alarm by the parameter). Diagnostics based on (with dosing pump active): - pressure switch disabled if time-based dosage (1.5 s reading delay); - no new pulse for longer than the time defined by the parameter if dosage by flowmeter.	OP
23	Drain failure	Triggered if the solenoid drain valve is open for longer than the set limit, if the washing chamber level is still active (washing chamber not emptied);	S
24	Fan failure	Diagnostics active if the delay parameter is not zero, for the following situations: - the fan pressure switch is inactive, having sent a command to turn the fan on at maximum speed; - the fan pressure switch is active, having sent a command to turn the fan off. The pressure switch reading is subject to the delay defined by the parameter	S

25	Minimum drying temperature not reached	The air temperature never reached the minimum limit defined by the parameter during drying with electric heating (or does not reach the drying set point when the latter has a value lower than the one defined by the parameter).	S
26	Prewashing temperature too high	The washing chamber temperature has risen above the maximum limit defined by the parameter during the prewashing phase.	OP
27	Chamber temperature too high	The temperature in the washing chamber exceeds the limit 102°C (operating limit to protect against overheating).	S
28	Drying temperature too high	The air temperature exceeds the limit 162°C (operating limit to protect against overheating).	S
29	Tank 1 temperature too high	In the configuration with tank 1 present, the air temperature in tank 1 exceeds the limit 100°C (operating limit to protect against overheating).	S
30	Chamber probe 1 failure	Fault in washing chamber temperature probe 1 (regulation probe)	S
31	Chamber probe 2 failure	Fault in washing chamber temperature probe 2 (redundancy probe).	S
32	Drying probe failure	Fault in air temperature probe (drying probe).	S
33	Tank 1 probe failure	In the configuration with tank 1 present, temperature probe fault in tank 1.	S
34	Chamb. probes temperature discrepancy	Triggered when the parameter relating to the control is set to YES, only during the treatment phase and if all the following conditions are satisfied: a) the washing chamber temperature is greater than the limit set by the parameter b) the washing chamber probe 2 differs from probe 1 by an absolute value greater than the maximum limit set by the parameter; c) the heating element in the washing chamber is inactive (the heating elements in the washing chamber are off or steam heating is inactive);	S
37	CAN serial connection failure	Lack of communication on the serial (Can Bus) connecting the master keyboard with the slave base boards.	S
39	No chamber heating	During the <u>electrical</u> heating of the washing chamber (washing chamber resistance on) the temperature increased by less than 1°C during the time set by the parameter.	S
41	No tank 1 heating	In the configuration with tank 1 present, during the <u>electrical</u> heating of tank 1, the temperature of tank 1 increased by less than 1°C during the time set by the parameter.	S
42	Thermal protection intervention	The thermal safety input is disabled with the safety contactor command on, or is active with the safety contactor command off (1.5 s reading delay).	S

46	Washing pump pressure switch failure	Diagnostics active if parameter = YES. The pressure switch of the washing impeller pump is disabled with the pump command on, or is active with the pump command off (diagnostics with the pump command on is bypassed during water supply and active draining). It intervenes with a reading delay as defined by the parameter.	S
47	Chemical flowmeter 1 failure	The flowmeter for the chemical additive 1 (detergent) signals surplus pulses above the limit defined by the parameter, with the dosing pump command off.	S
48	Chemical flowmeter 2 failure	The flowmeter for the chemical additive 2 (neutralising agent) signals surplus pulses above the limit defined by the parameter, with the dosing pump command off.	S
49	Chemical flowmeter 3 failure	The flowmeter for the chemical additive 3 (lubricant) signals surplus pulses above the limit defined by the parameter, with the dosing pump command off.	S
50	Chemical flowmeter 4 failure	The flowmeter for the chemical additive 4 (soda ash) signals surplus pulses above the limit defined by the parameter, with the dosing pump command off.	S
51	Cold water flowmeter failure	The flowmeter for the cold water signals surplus pulses above the limit defined by the parameter, with the water solenoid valve command closed.	S
52	Warm water flowmeter failure	The flowmeter for the warm water signals surplus pulses above the limit defined by the parameter, with the water solenoid valve command closed.	S
53	Demi water flowmeter failure	The flowmeter for the demineralised water signals surplus pulses above the limit defined by the parameter, with the water solenoid valve command closed.	S
54	Hepa filter obstructed	The air filter of the drying fan is clogged (5.0 s reading delay).	S
55	Conductivity meter failure	Electrical conductivity sensor error (Ex, with x = 1,..., 6) <ul style="list-style-type: none"> - E1: generic error - E2: measurement above the maximum limit - E3: measurement below the minimum limit - E4: sensor in short circuit - E7: Max limit for reset reached - E8: Conductivity meter status discrepancy - E9: MieleBus plug-in not recognised 	S

56	Conductivity too high	<p>The conductivity value exceeds the maximum limit set by the phase parameter.</p> <p>Conductivity is monitored in the prewashing/treatment phase, during which the "conductivity" phase parameter is enabled, 15" after the following activities:</p> <ul style="list-style-type: none"> - Wait time from completion of conductivity meter start-up - Water filling into the chamber complete - Chemical filling complete - Washing pump running from 15" after completion of water and chemical filling - The conductivity meter measurement is active from 20" <p>When the conductivity check has a negative outcome, the phase is repeated, draining the water first. The alarm occurs after 3 consecutive fails.</p>	S
58	No chamber heating	During steam heating of the chamber the temperature did not increase by 1°C within the time set by the parameter	S
59	No tank 1 heating	With tank 1 present, during steam heating the temperature did not increase by 1°C within the time set by the parameter	S
60	Failure on thermoregulation	<p>In the treatment phase, the thermoregulation timeout (equal to 30 min), which starts as soon as the temperature in the washing chamber reaches the set point + 0.5°C (with the water supply complete and any gradual chamber cooling concluded), has expired. Notifies an undefined situation of permanence in the phase for the following possible reasons:</p> <ul style="list-style-type: none"> a) temperature fluctuations above/below the set point due to a structural defect in the pipe. b) incorrect chemical input temperature setting (> thermoregulation set point) 	S
67	Door manually unlocked	During a power failure with the cycle running, the loading door was manually unlocked	OP
69	Humidity sensor failure	Humidity sensor failure	S
70	Water below tank drain level	During a prewashing, washing or rinse phase after water filling, before the pump starts, the minimum level sensor in the chamber was not activated	S
78	Tank 1 limit switch failure	<p>In the configuration with tank 1 present, it is triggered in one of the following conditions.</p> <ul style="list-style-type: none"> a) Inconsistent level switches: in tank 1 the lower maximum level (N.A.) is open and the upper maximum level (N.C.) is open (Diagnostics generated without any delay). b) Timeout for level switch transition: in tank 1, the maximum transition time between the lower and upper filling levels (and vice versa) during the supply/drain of the tank water has elapsed. 	S

85	No cold demi water	The type 4 water washing chamber supply was not completed (no new water flowmeter pulse for longer than the time set by the parameter).	S
86	Cold demi water flowmeter failure	The flowmeter for the type 4 water signals surplus pulses above the limit set by the parameter, with the water solenoid valve command closed.	S
91	DOS1 dosing failure	In the chemical dosage configuration with time control and flowmeter redundancy, for the dosage into the washing chamber of the chemical product from dosage unit 1 there was a difference in absolute value between the time-measured value and the flowmeter-measured value, greater than the maximum percentage error (with respect to the programmed quantity of chemical) set in the specific configuration parameter	S
92	DOS2 dosing failure	In the chemical dosage configuration with time control and flowmeter redundancy, for the dosage into the washing chamber of the chemical product from dosage unit 2 there was a difference in absolute value between the time-measured value and the flowmeter-measured value, greater than the maximum percentage error (with respect to the programmed quantity of chemical) set in the specific configuration parameter	S
93	DOS3 dosing failure	In the chemical dosage configuration with time control and flowmeter redundancy, for the dosage into the washing chamber of the chemical product from dosage unit 3 there was a difference in absolute value between the time-measured value and the flowmeter-measured value, greater than the maximum percentage error (with respect to the programmed quantity of chemical) set in the specific configuration parameter	S
94	DOS4 dosing failure	In the chemical dosage configuration with time control and flowmeter redundancy, for the dosage into the washing chamber of the chemical product from dosage unit 4 there was a difference in absolute value between the time-measured value and the flowmeter-measured value, greater than the maximum percentage error (with respect to the programmed quantity of chemical) set in the specific configuration parameter	S
97	Water leakage	The water leakage sensor is activated for longer than the time set by the parameter	S
98	Pump inverter communication failure	Diagnostics active if washing pump with ECS inverter Timeout on the RS485 communication serial between the keyboard and the washing pump inverter	S

99	Pump inverter alarm	Diagnostics active if washing pump with ECS inverter The washing pump inverter is in a state of alarm. The sub-code "Ex" or "Ax" is displayed: "Ex" indicates the active error code, "Ax" the specific active alarm code for the inverter (see inverter specification), with x number > 0	S
100	Inverter operating error	Frequency inverter failure (communication of status from the inverter not valid)	S
107	Leakage in tank 1	With tank 1 drain valve closed the tank level 2 is deactivated and the water filling is complete for a time less than "Max waiting time between levels on tank". With this parameter set to 0 the diagnostic is disabled.	S

11.3 List of warnings

Message displayed	Description	Responsible for warning resolution
Pump pressure transducer failure	Pressure transducer enabled by parameters but error on the sensor signal	S
Drain in progress	Drain in progress – it is necessary to wait until drain is complete	OP
Certificates not valid	Machine certificates not valid – they must be updated	S
Empty program	The program cannot be used because it is empty	S
Warning – hot material!!	The cycle finished with the temperature in the chamber over 65 °C – be careful when removing the load	OP
Wait	No operations can be carried out because another is ongoing	OP
Close door	The door must be closed to start the cycle	OP
Salt loading required	Salt loading is required to ensure the correct regeneration of the softener circuit	OP
Print in progress	Print in progress – it is necessary to wait for the print to complete before starting another cycle	OP
Cooling in progress	The temperature in the chamber is too high – chamber cooling is ongoing – this step must be completed before the load can be accessed	OP
Lack of chemical DOS1	The chemical product connected to dosing pump 1 in the canister is finished – to avoid an alarm during the next cycle it is advisable to replace the canister	OP
Lack of chemical DOS2	The chemical product connected to dosing pump 2 in the canister is finished – to avoid an alarm during the next cycle it is advisable to replace the canister	OP
Lack of chemical DOS3	The chemical product connected to dosing pump 3 in the canister is finished – to avoid an alarm during the next cycle it is advisable to replace the canister	OP

Lack of chemical DOS4	The chemical product connected to dosing pump 4 in the canister is finished – to avoid an alarm during the next cycle it is advisable to replace the canister	OP
Main board communication error	There is no communication between the control panel and the main board	S
Maintenance overdue	The maintenance interval has elapsed – new maintenance is needed – the description of the required maintenance is provided in the warning	OP / S

12. CONNECTIVITY

12.1 USB

There is a USB port on the loading side next to the control panel, which allows:

- ▶ saving of historical data
- ▶ saving of cycle data during execution, instead of printing

12.1.1 USB requirements

The USB needs to be formatted in FAT format.

The capacity of the USB must be maximum 32GB.



Only for SELV connections to external devices compliant with IEC 60950-1 or IEC 62368



12.1.2 Washing cycle print on USB

When running a cycle, it is possible to save the cycle settings, consumption data, and sensor values, using the USB.

If the USB is inserted and the following parameters on WORK data (page 1) are set to YES,

Work 1		en	CO / SYSTEM
Basket code (1: digital input, 2: barcode)	DIG INPUT		16/03/2022 09:49:30
Working cycle (0: manual, 1: basket recognition, 2: mixed)	CHOOSE		
Automatic print of consumption on USB	NO		
Automatic print of probe trend on USB	NO		
Automatic print of cycle settings on USB	NO		
Automatic print of consumption on printer	NO		
Automatic print of probe trend on printer	NO		
Automatic print of cycle settings on printer	NO		
Buzzer loading side - end cycle	YES		
Buzzer loading side - alarm	YES		

3 files will be saved during each cycle:

-  **PRT00157** Cycle execution data
-  **SET00157** Cycle settings data
-  **TMP00157** Probe sampling data

Each one is saved as a TXT file.

12.1.3 Saving historical data on USB

With a USB it is also possible to save all historical data regarding:

- ▶ Operator accesses
- ▶ Alarms
- ▶ Events
- ▶ Maintenance intervention

Each one is saved as a TXT file.

12.2 Network connection

The laboratory glassware washer can be integrated into an internal network via an Ethernet or WiFi interface.

Only the systems required for machine access via a web interface and for the documentation of reprocessing results (e.g., a PC on which the documentation software is installed) may be operated on this network.

1. The machine should be operated only in a separate network segment which meets one of the following requirements:
 - it is physically separated from other network segments
 - access to the segment is restricted by a firewall or a router which has been configured accordingly
2. Limit access to this separate network segment to persons requiring access in the course of their work.
3. Use strong passwords to protect access to systems that are connected to the machine.
4. Configure the Ethernet interface.

The type of connection can be defined in the SETTINGS menu, under TECHNICAL DATA 2, choosing between WiFi and Ethernet.

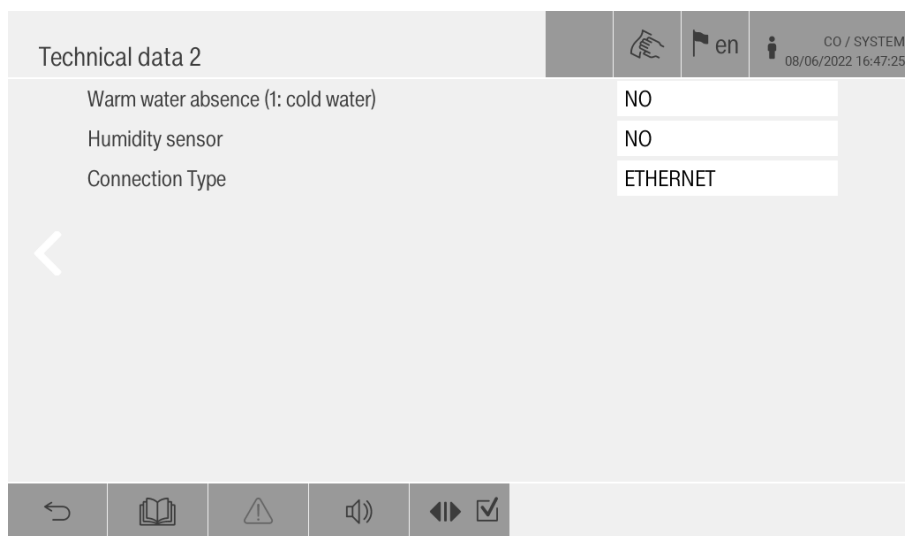
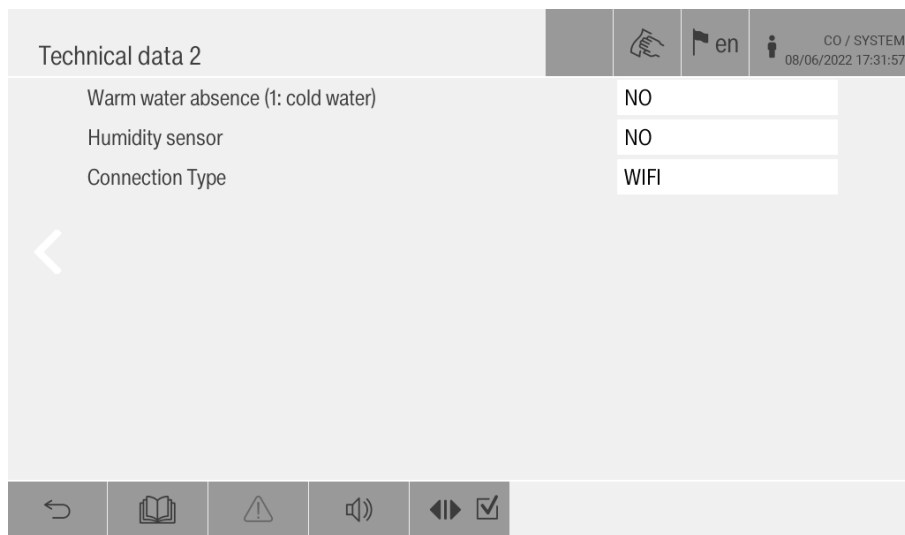

The UTILITY menu contains the NETWORK SETTING menu where the IP address or the DHCP function can be set.

If the machine is connected using WiFi, the SSID section is also active to connect the machine to an existing network.

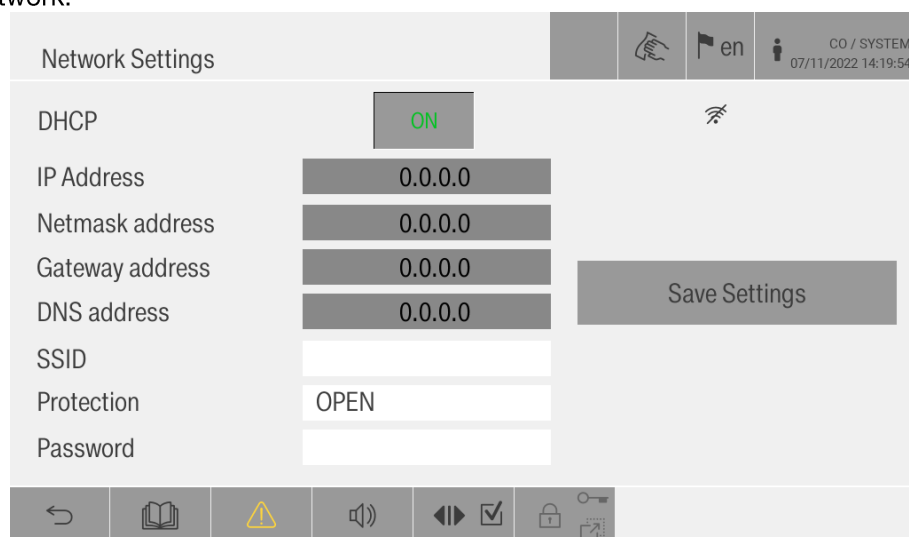

When the networking functions are activated and the device is connected to the Internet, the device sends the following data to the Miele Cloud:

- ▶ Device serial number
- ▶ Device model and technical features
- ▶ Device status
- ▶ Information about the software status of the device

Initially, this data cannot be assigned to a specific user and is not permanently saved. Data cannot be permanently saved or assigned to a specific user until after the device is linked to a user. Data transmission and processing are governed by Miele's strict security standards.



Settings in the machine, e.g., parameters for disinfection or dispensing process chemicals, may be changed as a result of unauthorized access via the network.
Under no circumstances should it be possible to access the machine via the Internet or other public or unsecured networks, either directly or indirectly (e.g., using port forwarding)!

12.2.1 Ethernet connection

There is an Ethernet port on the rear part of the control panel. This port allows connection to the traceability system or to the Miele Cloud platform.

The connection to these systems using the Ethernet port can only be made by trained technicians.

The connected external devices need to be compliant with IEC 60950-1 or IEC 62368-1. The cable used must be CAT5 or higher.

12.2.2 WiFi connection

The machine is also equipped with a WiFi connection allowing the device to be connected to the traceability system or the Miele Cloud platform.

The connection to these systems using WiFi can only be made by trained technicians.

The WiFi connection must be made according to 802.11b/g/n.

12.3 Miele Cloud

The laboratory glassware washer can be connected to a cloud called MieleCloud. The settings needed for access are inserted in the following page in the UTILITY menu.

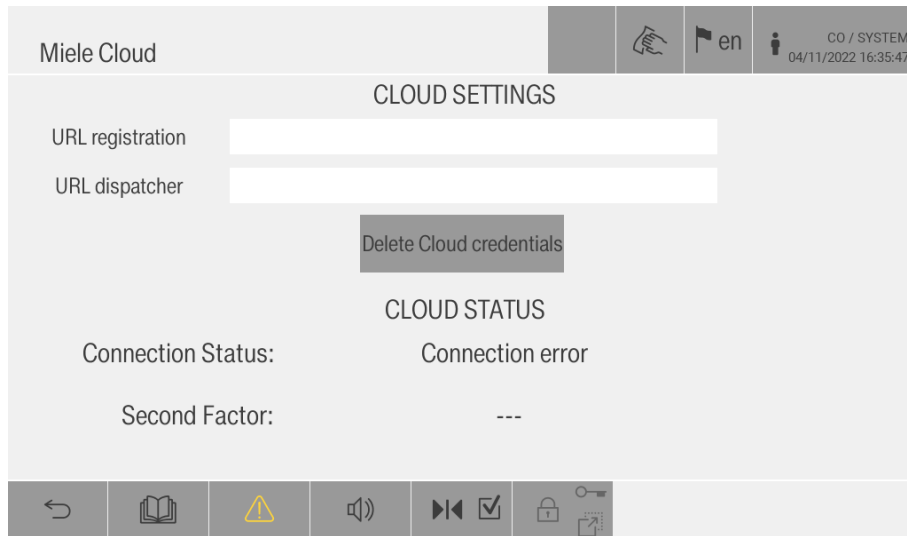

The machine automatically connects to the Cloud platform when switched on, if the machine is connected to a network. The URL registration and URL dispatcher fields are automatically filled. The technician must run the start-up procedure on the Cloud page in order to record and identify the machine.

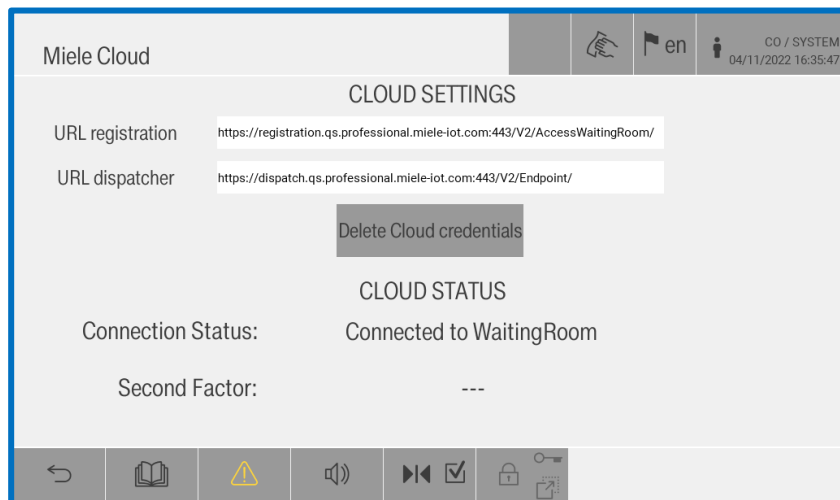

Connection Status:

When the machine tries to access the Miele Cloud, on the Connection State field “Connected to WaitingRoom” is displayed.

As soon as the technician gains access, the machine status will automatically change to “Connecting...” and then “Connected to Miele Prof Cloud”.

The “Second Factor” field will then be filled by the system.

In case of an error, the writing “Connection error” will be shown.



When the machine is connected to the WiFi network and the connection is lost, the machine is able to reconnect automatically as soon as the connection is restored

12.4 Miele Local Diagnosis

If the machine needs to be connected directly to the diagnostic tool, the technician needs to log in via this page with the Username and Password defined by the manufacturer.

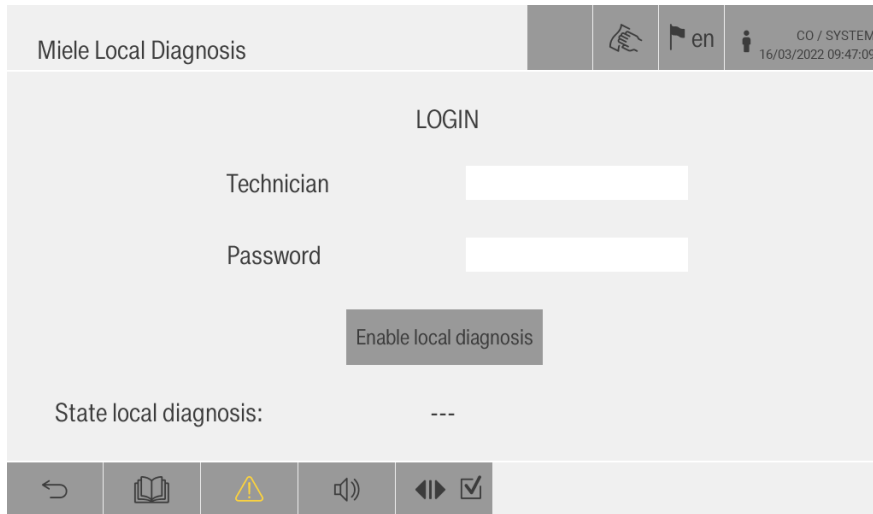

The screenshot shows the 'Miele Local Diagnosis' interface. At the top left, the title 'Miele Local Diagnosis' is displayed. On the top right, there are icons for a hand, a flag with 'en', and a user icon, along with the text 'CO / SYSTEM' and the date/time '16/03/2022 09:47:09'. The main area is titled 'LOGIN' and contains two input fields: 'Technician' and 'Password'. Below these fields is a button labeled 'Enable local diagnosis'. At the bottom of the main area, it says 'State local diagnosis: ---'. The bottom navigation bar includes icons for back, home, warning, volume, and a checkmark.

When the data has been entered, the machine connects automatically to the tool. After the connection has been established, the machine is able to exchange the data and status of the machine, to help the technician during the diagnostic operations.

It is not necessary to set an IP address, because the machine has a unique address dedicated to this specific tool.

13. MAINTENANCE

13.1 General recommendations on maintenance

Maintenance for the machine described in this manual can be divided into routine maintenance and special maintenance.

The operators and maintenance technicians, in normal operating conditions, are not subject to risks if they work safely using suitable means of protection.

In order to work safely the operator and maintenance technician must:

- ▶ Carefully comply with the instructions set forth in this manual.
- ▶ Use safety devices appropriately and with care, as well as the group and individual safety gear provided in the workplace.
- ▶ Take special care when making repairs or replacing mechanical parts (e.g. drain pump, etc.) on malfunctioning machines which have not completed the thermal disinfection cycle.

13.1.1 Machine status

The machine must be completely switched off. The person responsible for said task must ensure that the safety of other people nearby is not compromised. The main switch must be in the OFF position.

13.1.2 Safety systems

The machine should only be operated in compliance with valid standards and regulations concerning the use of disinfectants (cf. data sheets for individual products). Rules concerning contact with machine parts potentially contaminated with pathogens also apply. Personal protective gear must be worn.

13.1.3 Procedure

If possible, run a disinfection program for the washing chamber. Open the washing chamber door and wipe with a suitable disinfectant.

Wipe all internal parts as well as any baskets and their contents.

Leave the disinfectant to act for the required amount of time (see the product data sheet or safety data sheet for the disinfectant in question).

When performing maintenance on parts of the machine which have not been reached by the disinfectant, take appropriate precautions and use suitable safety gear.

13.1.4 Decontamination procedures

Before making repairs or replacing mechanical parts (e.g. drain pump, heating elements, etc.) in cases where disinfection has not been completed, the disinfection procedure must first be carried out in order to eliminate any pathogenic residue.

13.1.5 Machine status verification

After a maintenance intervention, to check if the machine is working properly, run a cycle to check that all its functions have been restored.

13.2 Maintenance reminder

The machine displays a maintenance reminder, with a description of the elapsed interventions, after a specified time or specified number of operating hours. This warning does not affect normal use of the machine.

Any due maintenance must be carried out in the shortest possible time.

To clear the maintenance warning, proceed as follows:

1. Carry out the maintenance intervention on the machine as described in the procedures below and according to the table.
2. From the MAIN MENU, open the SYSTEM menu:

SYSTEM → MAINTENANCE → MAINTENANCE INTERVENTION

3. Select the type of maintenance at point ①, provide a description of the intervention at point ②, insert the time needed at point ③ and the name of the operator at point ④.

Once filled in, confirm and save the intervention with the button ✓.

The screenshot displays the 'MAINTENANCE INTERVENTION' screen. At the top, the title 'MAINTENANCE INTERVENTION' is visible. The screen contains several input fields and labels: 'Date intervencion' is set to '16/03/2022', 'Working hours' is '200'. A dropdown menu for 'Maintenance type' is set to '1' with 'BIANNUAL' displayed. A large text area for 'Note' is present. 'Total time (hh:mm)' is shown with two empty input boxes separated by a colon. 'Next maintenance' is set to '12/09/2022' and 'Hours' is '2200'. A 'Technician' field is at the bottom. The bottom navigation bar includes icons for back, home, warning, volume, and a checkmark.

13.3 Routine maintenance

Routine maintenance includes all work aimed at keeping various parts of the machine clean and functional. Such work must be performed on a regular basis or when it is considered necessary. Since these are simple cleaning tasks, they are normally performed by the machine operators at their own risk. The following table shows the various routine maintenance tasks, their frequency and who is to perform them. Each task is described in more detail on the following pages.

Routine maintenance tasks must be performed at the intervals set forth in the table. It is however advisable to carry out single cleaning tasks whenever necessary.

TABLE OF ROUTINE MAINTENANCE TASKS

Component	Responsibility	Maintenance interval	Activity	Ref
<i>Chamber filters: - sump filter - surface filter</i>	OP	EVERY DAY	Remove the filters and clean them under running water and if necessary, use a brush	M1
<i>Washing arms</i>	OP	EVERY WEEK	Check the correct rotation of the washing arms Remove the washing arms and clean them under running water	M2
<i>Disinfection and cleaning of washing chamber</i>	OP	EVERY WEEK	Disinfection of the chamber, basket, and hydraulic circuit	M3
<i>Cleaning of external panels</i>	OP	EVERY WEEK	Disinfection of the machine's external surfaces	M4
<i>Drying pre-filter</i>	OP	EVERY 6 MONTHS or 500 working hours	Replace	M5
<i>Cleaning of washing chamber temperature probes</i>	OP	EVERY 6 MONTHS or 500 working hours	Cleaning of temperature probes to remove dirt and limescale	M6
<i>Limescale removal treatment</i>	OP	WHEN NECESSARY	Removal of limescale deposits from the chamber	M7

OP: operator

N.B.:

Routine maintenance tasks must be performed at the intervals set forth in the table. It is however advisable to carry out single cleaning tasks whenever deemed necessary.



It is advisable to carry out a general check-up and to clean the appliance regularly, particularly if the supply water is very hard.

Particular attention should be paid to the heating element and thermostat probe

Even if the supply water is soft, the high operating temperatures may cause limescale to build up.

Apart from damaging the heating element, limescale can also clog the nozzles, in which case the correct tank temperature for thermal-disinfection may not be reached.

WARNING:

- ▶ Do not clean the machine outside with pressurised water.
- ▶ Contact your trusted supplier of cleaning products for details concerning the recommended methods and products for regular sanitisation of the machine.

CHAMBER FILTERS and CLEANLINESS of float switch

Reference: **M1**

Responsibility: **OP**

Frequency: **EVERY DAY**

Follow the instructions below:

- ▶ Open the washing chamber door and extract the basket
 - ▶ Extract the filter from the chamber and the filter from the sump.
 - ▶ Check if the float switch moves freely and clean it if necessary.
 - ▶ To clean the level switch, remove the clips on the top and remove the float. Clean the float with running water and the central part with a cloth. Then reassemble the float switch.
-

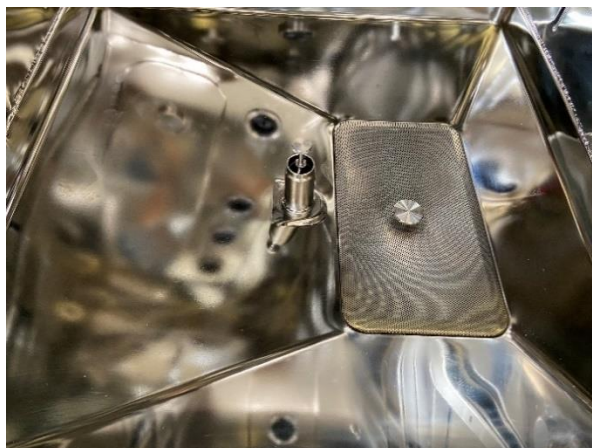



-
- ▶ Clean the filters under running water. Remove any residue with a soft brush if necessary.
 - ▶ Remove and clean any deposits and encrustations from the washing chamber drain.
 - ▶ Place both filters in their original position
-

CLEANING THE WASHING ARMS

Reference: **M2**

Responsibility: **OP**

Frequency: **EVERY WEEK**

Follow the instructions below:

- ▶ Open the washing chamber door and extract the basket
 - ▶ Unscrew the lock pin of the machine and basket washing arms
-

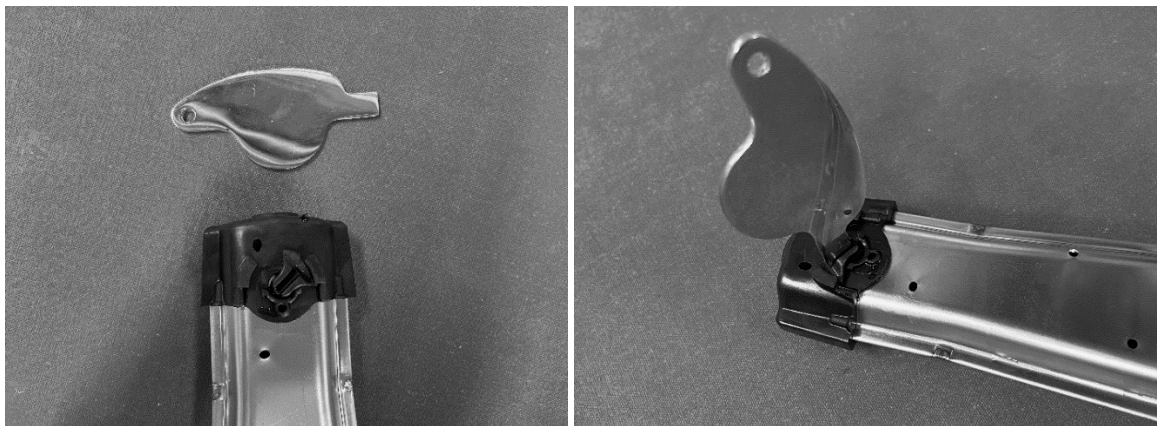

- ▶ Unscrew the pin from the washing arm end cap
 - ▶ Remove the end cap and wash the washing arms under running water **and brush them with a soft brush if necessary**
-

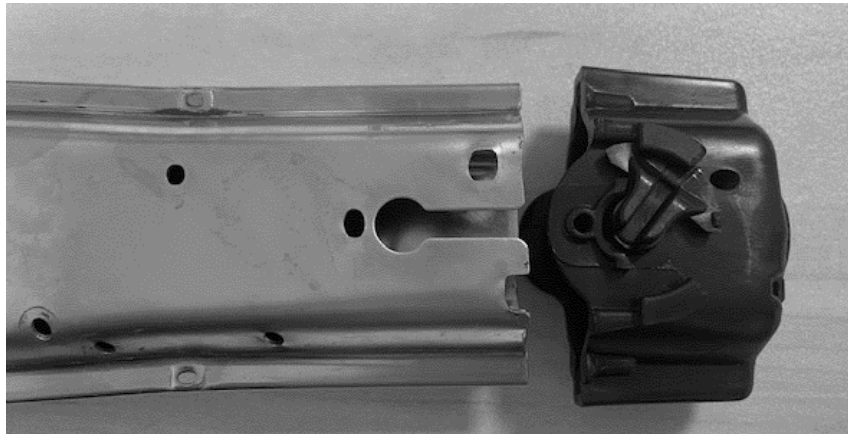

- ▶ Assemble the end cap and fasten the pin
- ▶ Screw the washing arms back into their original position, making sure not to mix up the machine and basket washing arms

To identify the machine washing arm, check the holes:

- **MACHINE WASHING ARM: no holes on the rear part**

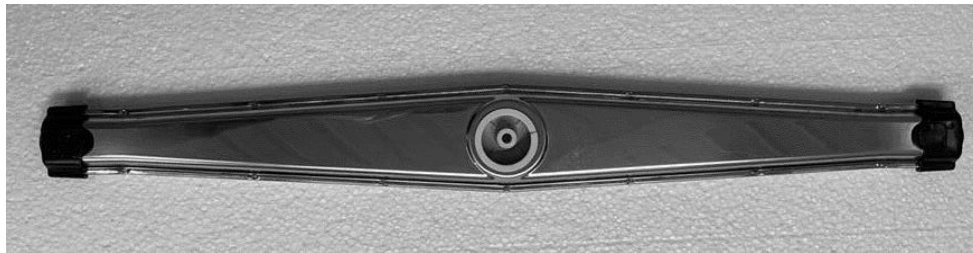

- **BASKET WASHING ARM: holes on the rear part**

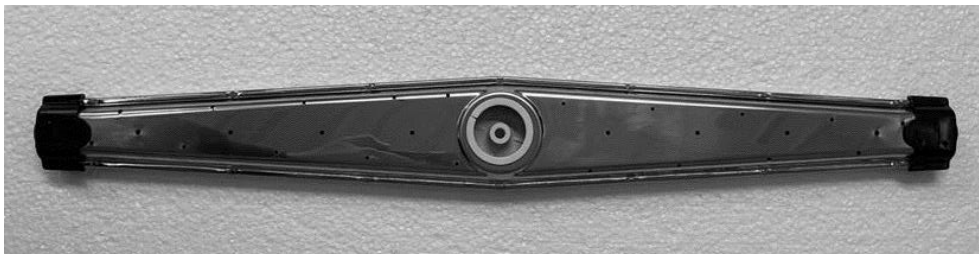

DISINFECTION AND CLEANING OF WASHING CHAMBER

Reference: M3	Responsibility: OP	Frequency: EVERY WEEK
----------------------	---------------------------	------------------------------

Follow the instructions below:

Run an empty washing cycle with a basket inside to carry out the thermal-disinfection process inside the washing chamber. This will guarantee the complete disinfection of the washing chamber, basket, and hydraulic circuits.

If it is not possible to run an empty washing cycle, it is advisable to proceed with the disinfection of the machine as described below:

- ▶ Open the access door to the chamber and check that no equipment, trays, or instruments have been left in the washing basket.

-
- ▶ Inside the washing chamber, evenly spray a disinfectant compatible for use on stainless steel surfaces, and which contains the following active ingredients:
 - quaternary ammonium salts
 - or
 - chlorhexidine digluconate – ammonium chloride – isopropyl or ethyl alcohol
 - ▶ All internal accessible parts must be treated in accordance with this procedure.



-
- ▶ As regards the contact time and methods of use of the disinfectant used, follow the instructions provided in the technical data sheet of the product itself
 - ▶ Always check the compatibility of the chemical product with the materials it will be used on; this information can be found in the technical data sheet of the chemical product used
 - ▶ The disinfectant must be applied in the chamber when the surfaces are cold to avoid the inhalation of harmful fumes released by the product.
-

CLEANING THE EXTERNAL PANELS OF THE MACHINE

Reference: **M4**

Responsibility: **OP**

Frequency: **EVERY WEEK**

Follow the instructions below:

- ▶ Spray a disinfectant on all external surfaces of the machine which is compatible for use on stainless steel surfaces, and which contains the following active ingredients:
 - quaternary ammonium salts
 - or
 - chlorhexidine digluconate – ammonium chloride – isopropyl or ethyl alcohol
-



- ▶ As regards the contact time and methods of use of the disinfectant used, follow the instructions provided in the technical data sheet of the product itself
 - ▶ Always check the compatibility of the chemical product with the materials it will be used on; this information can be found in the technical data sheet of the chemical product used
 - ▶ The disinfectant must be applied in the chamber when the surfaces are cold to avoid the inhalation of harmful fumes released by the product.
-

PRE-FILTERS REPLACEMENT

Reference: **M5**

Responsibility: **OP**

Frequency: **EVERY 6 MONTHS**

Follow the instructions below:

- ▶ Open the lower technical area door where chemical products are placed
 - ▶ Use the bracket for opening
 - ▶ Remove the bracket
 - ▶ Extract the filter
-

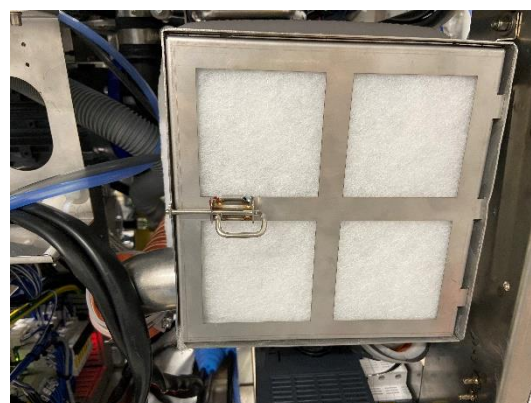
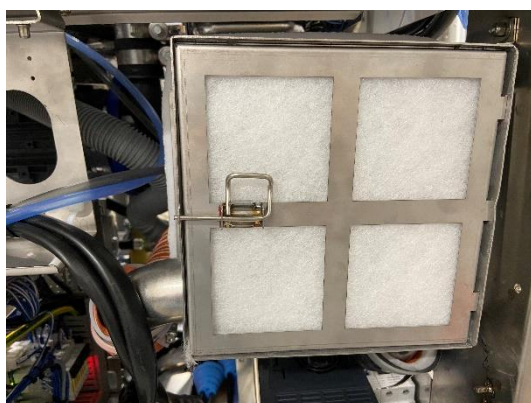

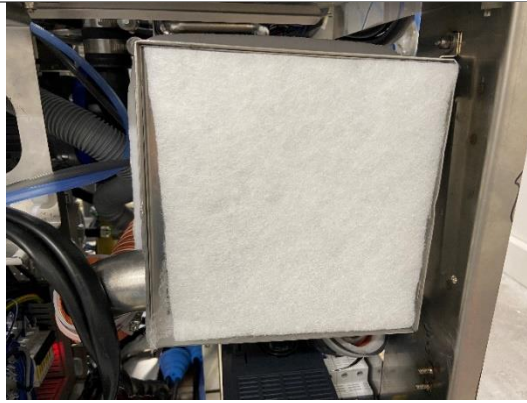

-
- ▶ Replace the filter and fix it in the original position
 - ▶ Place and fix the bracket.
-

CLEANING THE WASHING CHAMBER TEMPERATURE PROBES

Reference: **M6**

Responsibility: **OP**

Frequency: **EVERY 6 MONTHS**

Follow the instructions below:

- ▶ Open the washing chamber door and extract the basket
- ▶ Check the chamber temperature probes (on top of the chamber on the left side) and remove any deposits or limescale using a damp cloth and an appropriate detergent.



Take care not to damage or move the probes

LIMESCALE REMOVAL TREATMENT

Reference: **M7**

Responsibility: **OP**

Frequency: **WHEN
NECESSARY**

Follow the instructions below:

Use a descaling agent (we recommend vinegar) during an empty washing cycle with cold water (this is usually carried out every week unless a properly configured water softener is used, either built-in to the machine or provided on-site).

As regards the quantity of product to use, follow the instructions provided in the technical data sheet of the product itself. If vinegar is used, use 0.5 litres.

The descaling product must be poured into a container of the same size, positioned on an empty loading basket.

Use a washing program with water at room temperature, without activating the drying cycle.



Even if the feed water only contains a small amount of limescale, high temperatures can generate the formation of limescale residue. This, as well as problems potentially affecting the heating element, may cause the blockage of the nozzles, jeopardising the correct washing process and preventing the ideal disinfection temperature from being reached in the washing chamber

13.4 Drying air filtration

The machines are equipped standard with an air filter (class 5) in accordance with EN 779, and a HEPA H14 filter in accordance with EN 1822.

The class 5 air filter can be replaced by a trained operator or technician in charge of the installed machine.

The HEPA filter must be replaced during annual maintenance by a Miele service technician.

13.5 Changing the paper roll on printer

To change the paper roll, proceed as follow:

1. Press the OPEN key to open the printer cover

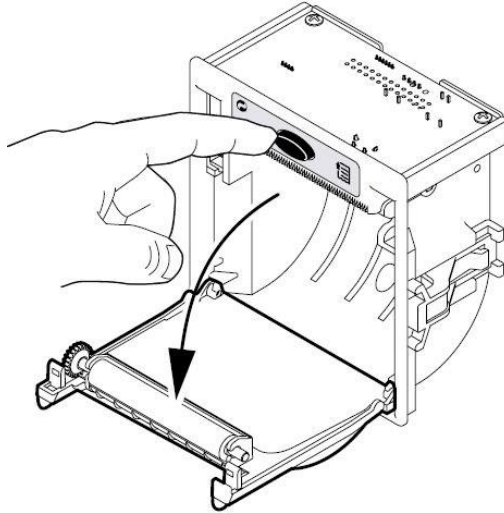

2. Remove the old plastic roll
3. Place the paper roll making sure it unrolls in the proper direction

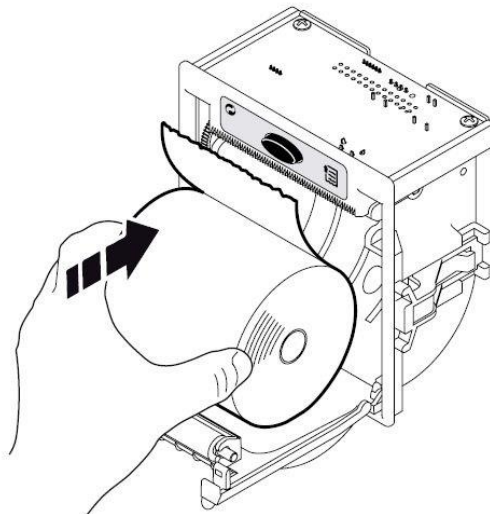

4. Take out the paper and close the cover

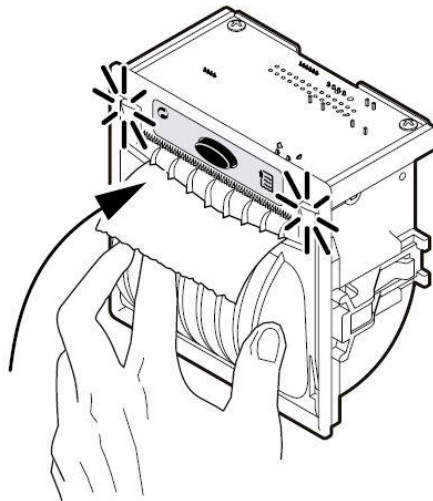

5. Tear off the exceeding paper using the jagged edge

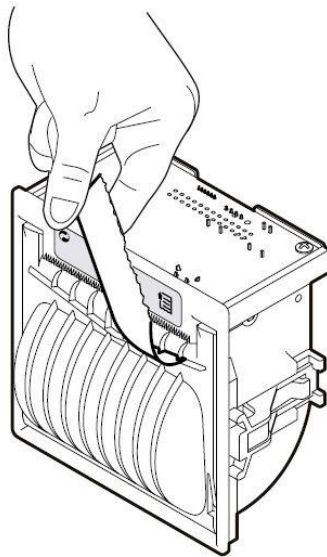

14. Problems – Causes – Remedies

14.1 Introduction

This chapter includes possible problems that may occur during machine operation, along with their causes and remedies. If the problems persist or regularly occur even after following the instructions in this chapter, please contact the Miele Customer Service Department.

14.2 Problem (P) – Cause (C) - Remedy (R)

P. MACHINE DOES NOT START:

C. Circuit breaker deactivated.

R. Check the power supply.

P. WASHING PROGRAM DOES NOT START:

C. Door not closed correctly.

R. Check door closure.

C. Lack of process chemicals.

R. Replace the chemical container and select "Fill DOSx"

P: MACHINE DOES NOT REACH SET TEMPERATURE FOR THE SELECTED PROGRAM:

C. Deposits on thermostat probe in washing chamber.

R. Clean the thermostat probe in the washing chamber as described under "Maintenance".

P. MACHINE DOES NOT RUN THE WASHING PROGRAM PROPERLY:

C. Nozzles are clogged by deposits or limescale.

R. Clean the nozzles or washing arms as described under "Maintenance".

C. Lack of water.

R. Ensure sufficient water pressure and remove blockages.

C. Insufficient water supply for the relevant program.

R. Shut off the water supply and clean the inlet filters (SERVICE).

P. INCORRECT DISPENSING:

C. Chemical dispenser pump is not working properly.

R. Perform routine maintenance and contact the Miele Customer Service Department or an authorised and trained service technician.

P: MACHINE DOES NOT DRY:

C. Air filter of drying system is dirty or clogged.

R. Contact the Miele Customer Service Department to replace the filter.

C. The fan of the drying system does not work.

R. Contact the Miele Customer Service Department or an authorised and trained service technician.



STEELCO S.p.A.

Via Balegante, 27 - 31039 Riese Pio X (TV) ITALIA