

M.-Nr. 12 312 301 / 00

**⚠ To prevent accidents and appliance damage, read the Operating and Installation Instructions before installation or use.**

**CAUTION:** During the installation process, please be careful of sharp edges that can cause harm.

**⚠ Pour prévenir les accidents et éviter d'endommager l'appareil, veuillez lire les instructions d'utilisation et d'installation avant l'installation ou l'utilisation.**

**AVERTISSEMENT :** Durant l'installation, veuillez faire attention aux rebords tranchants qui pourraient vous blesser.

**⚠ Antes de instalar y usar el aparato y con el fin de prevenir accidentes y daños al mismo, lea el Manual de uso y manejo correspondientes.**

**PRECAUCIÓN:** Durante el proceso de instalación, tenga cuidado con los bordes afilados que pudieran ocasionar daños.

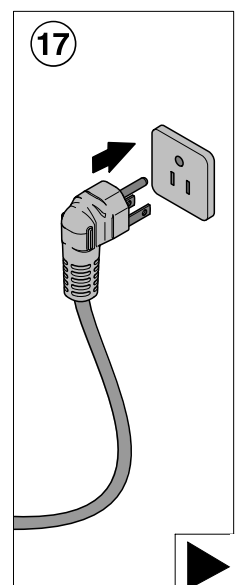
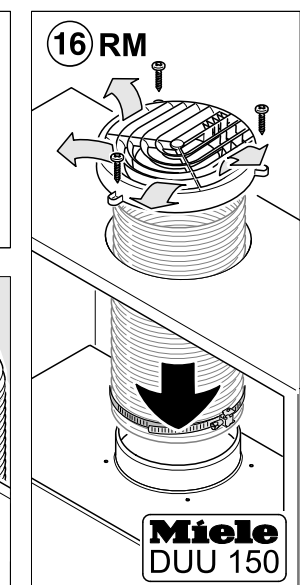
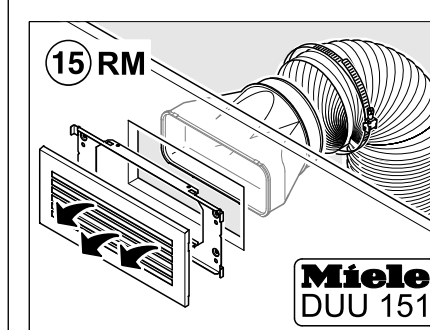
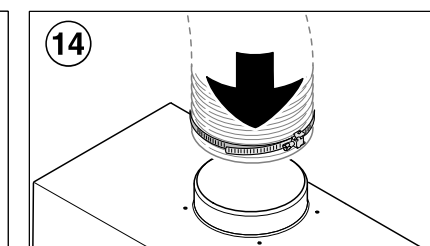
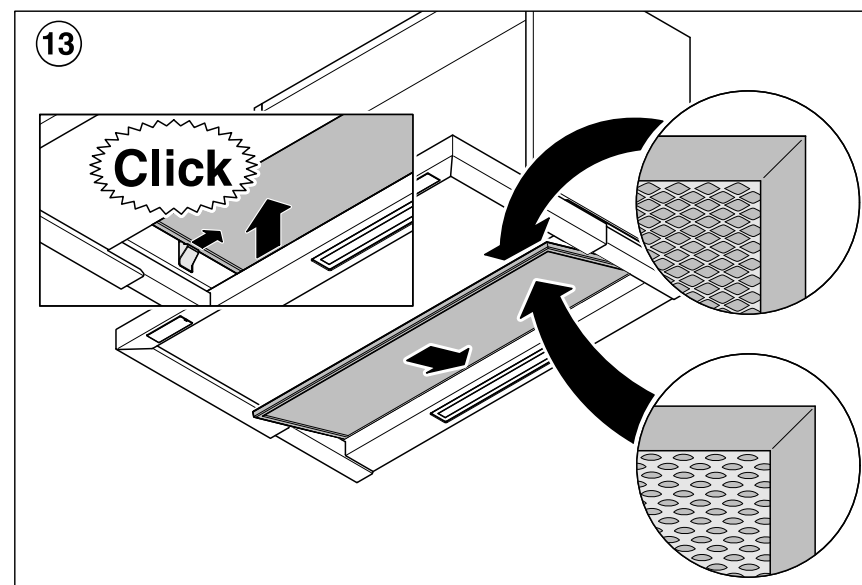
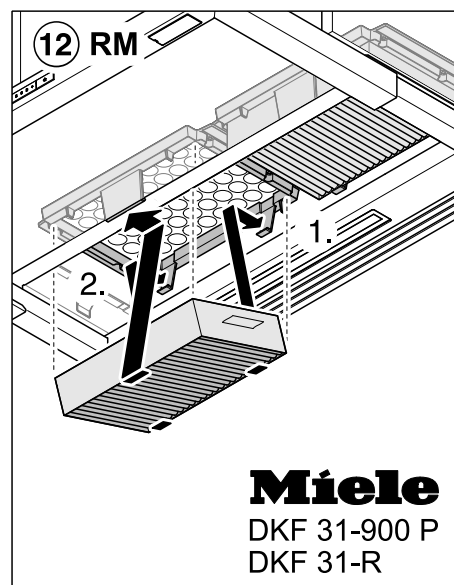
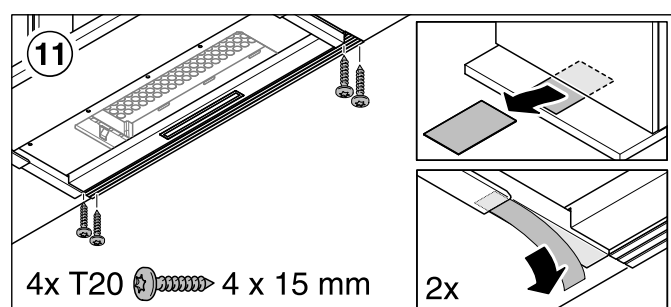
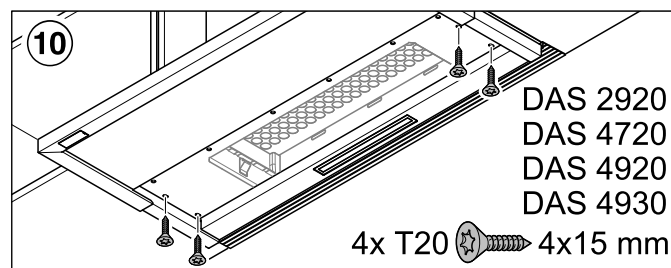
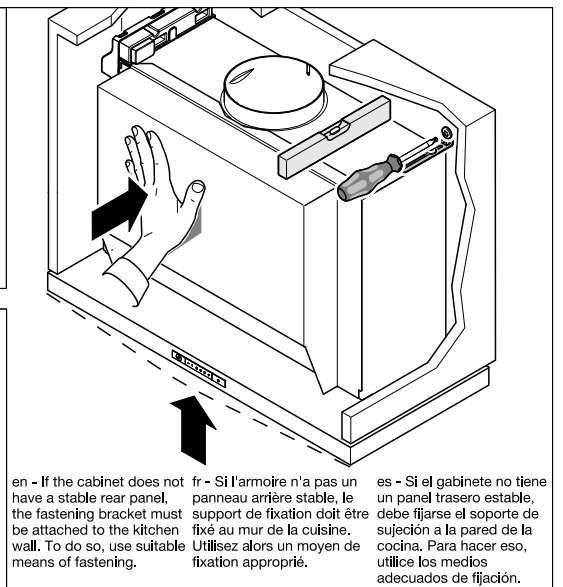
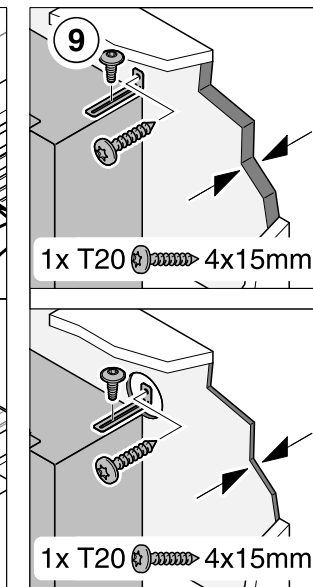
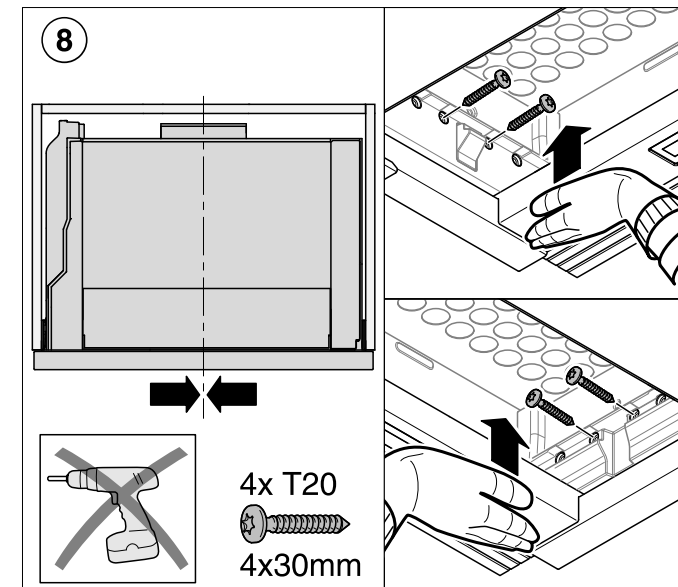
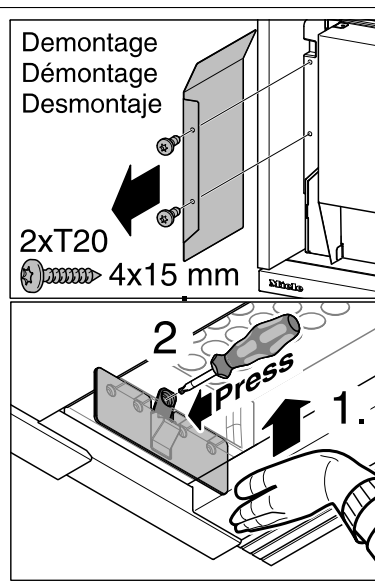
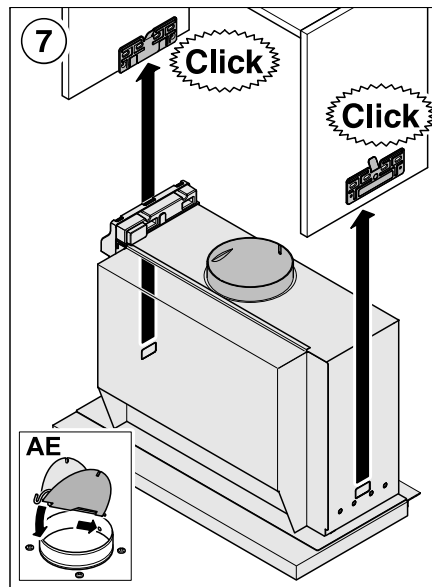
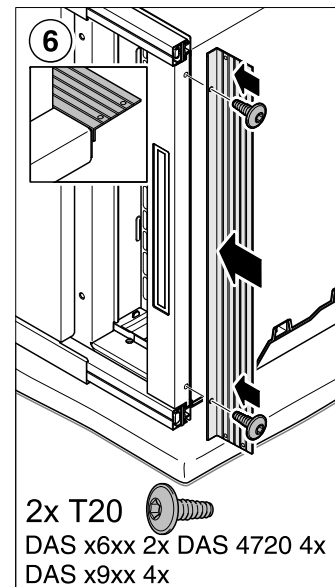
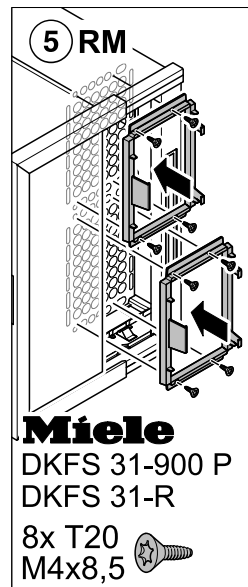
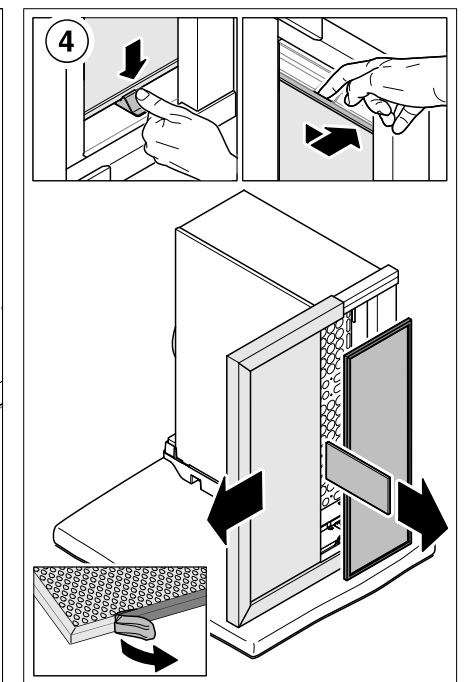
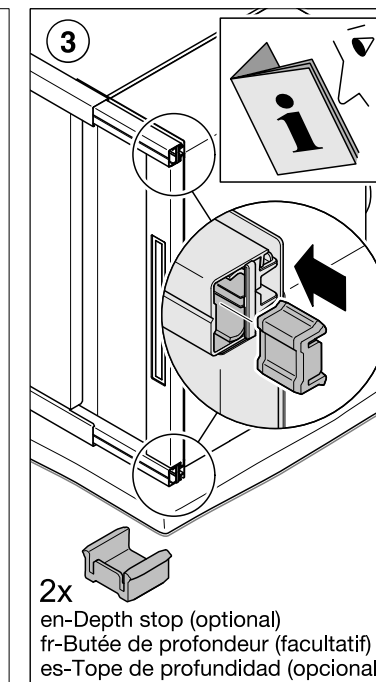
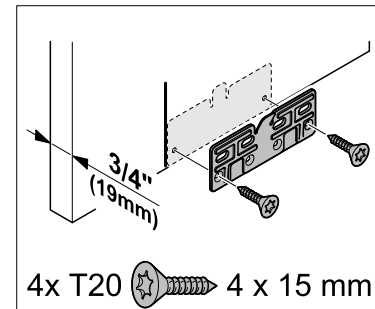
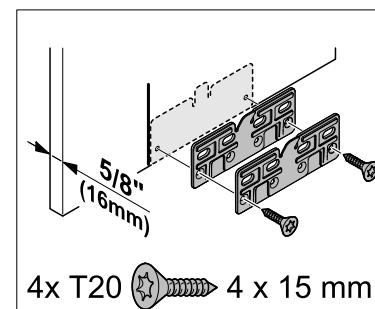
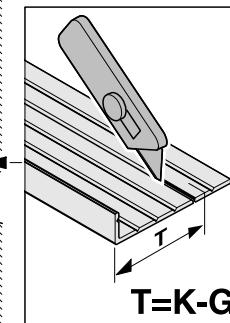
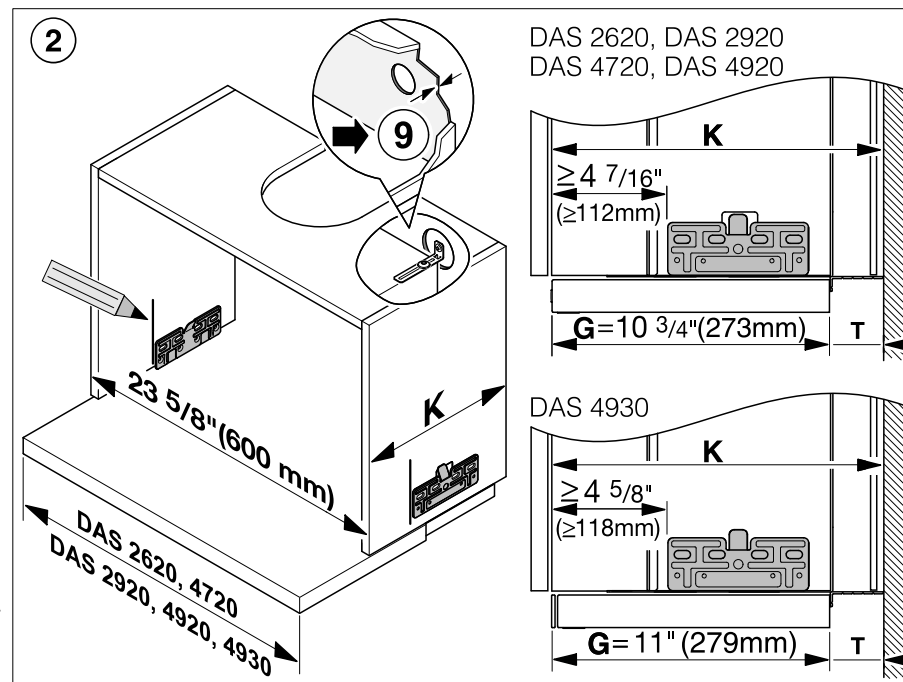



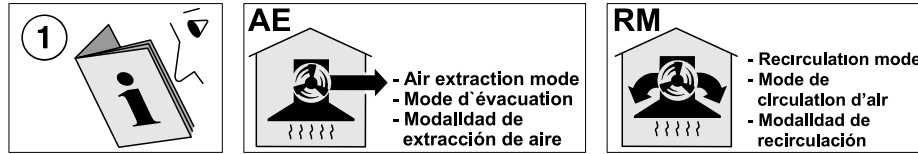

**⚠ To prevent accidents and appliance damage, read the Operating and Installation Instructions before installation or use.**

**CAUTION:** During the installation process, please be careful of sharp edges that can cause harm.

**⚠ Pour prévenir les accidents et éviter d'endommager l'appareil, veuillez lire Instructions d'utilisation et d'installation avant l'installation ou l'utilisation.**

**AVERTISSEMENT :** Durant l'installation, veuillez faire attention aux rebords tranchants qui pourraient vous blesser.

**⚠ Antes de instalar y usar el aparato y con el fin de prevenir accidentes y daños al mismo, lea el Manual de uso y manejo correspondientes.**

**PRECAUCIÓN:** Durante el proceso de instalación, tenga cuidado con los bordes afilados que pudieran ocasionar daños.

