

## Operating and installation instructions Built-in coffee machine



To avoid the risk of accidents or damage to the appliance, it is **essential** to read these instructions before it is installed and used for the first time.

# Caring for the environment

---

## Disposal of the packing material

The transport and protective packaging has been selected from materials which are environmentally friendly for disposal, and can normally be recycled.

Recycling the packaging reduces the use of raw materials in the manufacturing process and also reduces the amount of waste in landfill sites.

Ensure that any plastic wrappings, bags etc. are disposed of safely and kept out of the reach of babies and young children. Danger of suffocation.

**Only for Australia:** Note for installer: Expanded polystyrene (EPS) packaging included. Please retain and dispose of EPS packaging responsibly. For further information, please contact Miele.

## Saving energy

**The following tips can help you save energy and money as well as care for the environment:**

- Operate the coffee machine in Eco mode (default setting).
- Switch off the time of day display.
- Select dimmer lighting or refrain from using any lighting.
- Switch off the lighting when the appliance is switched off.
- Select the dark colour scheme for the display.
- Reduce the brightness of the display.
- If you change the factory default settings for the “Timer”, this can increase the energy consumption of the coffee machine.
- Pay particular attention to the following message in the display: This setting increases energy consumption.

- Switch the coffee machine off with the Ⓛ On/Off switch if it is not going to be used for a while.

## Disposing of your old appliance

Electrical and electronic appliances often contain valuable materials. They also contain specific materials, compounds and components, which were essential for their correct function and safety. These could be hazardous to human health and to the environment if disposed of with your domestic waste or if handled incorrectly. Please do not, therefore, dispose of your old appliance with your household waste.





Please dispose of it at your local community waste collection / recycling centre for electrical and electronic appliances. You are also responsible for deleting any personal data that may be stored on the appliance prior to disposal. Please ensure that your old appliance poses no risk to children while being stored prior to disposal.

|   |           |
|---|-----------|
| <b>Caring for the environment</b> .....             | <b>2</b>  |
| Saving energy.....                                  | 2         |
| <b>Warning and Safety instructions</b> .....        | <b>7</b>  |
| <b>Guide to the appliance</b> .....                 | <b>14</b> |
| Milk flask.....                                     | 16        |
| Central spout with cup rim sensor .....             | 16        |
| Symbols in the display.....                         | 17        |
| <b>Operating principles</b> .....                   | <b>18</b> |
| Touch display.....                                  | 18        |
| Operating actions .....                             | 19        |
| <b>Miele@home</b> .....                             | <b>22</b> |
| <b>Before using for the first time</b> .....        | <b>23</b> |
| Before using for the first time.....                | 23        |
| Switching on for the first time .....               | 23        |
| Setting up the bean system.....                     | 26        |
| <b>Bean system</b> .....                            | <b>28</b> |
| Changing bean system settings (Type of beans).....  | 28        |
| Renaming type of beans .....                        | 28        |
| Changing the allocation of the bean containers..... | 29        |
| <b>Filling the water container</b> .....            | <b>30</b> |
| <b>Switching on and off</b> .....                   | <b>31</b> |
| Switching the coffee machine on.....                | 31        |
| Switching the coffee machine off .....              | 31        |
| Preparing for extended disuse.....                  | 31        |
| <b>Making drinks</b> .....                          | <b>32</b> |
| Coffee.....   | 32        |
| Coffee drinks in detail .....                       | 32        |
| Milk and milk alternatives.....                     | 32        |
| Filling and fitting the milk flask.....             | 33        |
| Making a coffee drink.....                          | 34        |
| Cancelling preparation .....                        | 34        |
| DoubleShot.....                                     | 34        |
| Making two portions ☐.....                          | 34        |
| Preparing a pot of coffee .....                     | 35        |
| Tea .....   | 35        |
| Making tea .....                                    | 36        |
| Starting the TeaTimer manually .....                | 36        |
| Preparing a pot of tea.....                         | 37        |
| Preparing warm and hot water .....                  | 37        |

# Contents

---

|  |           |
|--|-----------|
| Changing the portion size .....  | 37        |
| <b>Expert mode</b> .....   | <b>38</b> |
| Switching Expert mode on and off.....  | 38        |
| Expert mode: allocating bean containers .....  | 38        |
| Expert mode: changing the portion size .....   | 38        |
| <b>Grinder setting</b> .....   | <b>39</b> |
| Recognising the correct grinder setting.....   | 39        |
| Adjusting the grinder setting .....  | 39        |
| <b>Parameters</b> .....  | <b>40</b> |
| Type of beans.....   | 40        |
| Amount of coffee .....   | 40        |
| Pre-brewing ground coffee .....  | 40        |
| Brewing temperature for coffee drinks.....   | 40        |
| Dispensing temperature for tea drinks, warm water and hot water .....  | 40        |
| Portion size.....  | 40        |
| Displaying and changing parameters .....   | 41        |
| Resetting drink settings.....  | 41        |
| <b>User profiles</b> .....   | <b>42</b> |
| User profiles .....  | 42        |
| Creating a profile .....   | 42        |
| Editing a profile .....  | 42        |
| Setting change of profile .....  | 42        |
| <b>Profiles: creating and editing drinks</b> .....   | <b>43</b> |
| <b>MyMiele</b> .....   | <b>44</b> |
| <b>MobileStart</b>  .....               | <b>45</b> |
| Switching MobileStart  on and off ..... | 45        |
| <b>Settings</b> .....  | <b>46</b> |
| Displaying and changing settings .....   | 46        |
| Language.....  | 46        |
| Time of day .....  | 46        |
| Date .....   | 46        |
| Start screen.....  | 46        |
| Timer .....  | 47        |
| Appliance timer .....  | 47        |
| Maintenance timer .....  | 47        |
| TeaTimer.....  | 48        |
| Volume .....   | 48        |

|   |           |
|---|-----------|
| Display .....   | 48        |
| Display brightness .....  | 48        |
| Colour scheme .....   | 48        |
| QuickTouch .....  | 48        |
| Lighting.....   | 48        |
| Info (display information) .....  | 48        |
| Mains water .....   | 48        |
| Altitude.....   | 49        |
| Performance mode.....   | 49        |
| Eco mode .....  | 49        |
| Barista mode .....  | 49        |
| Latte mode.....   | 49        |
| Party mode .....  | 49        |
| Water hardness.....   | 50        |
| Proximity sensor .....  | 51        |
| System lock  ..... | 51        |
| Miele@home .....  | 51        |
| Remote control .....  | 52        |
| SuperVision .....   | 52        |
| RemoteUpdate .....  | 52        |
| Software version.....   | 53        |
| Legal information .....   | 53        |
| Showroom programme (Demo mode) .....  | 53        |
| Factory default settings.....   | 53        |
| <b>Cleaning and care .....</b>  | <b>54</b> |
| Cleaning intervals - Quick guide.....   | 54        |
| Cleaning by hand or in the dishwasher .....   | 55        |
| Unsuitable cleaning agents.....   | 56        |
| Cleaning the drip tray and waste container.....   | 56        |
| Cleaning the drip tray cover.....   | 58        |
| Cleaning the water container.....   | 58        |
| Cleaning the central spout .....  | 59        |
| Cleaning the cup rim sensor .....   | 61        |
| Cleaning the milk flask with lid .....  | 61        |
| Cleaning the milk valve (daily) .....   | 62        |
| Removing and cleaning the milk valve (once a month).....  | 62        |
| Cleaning the bean containers .....  | 65        |
| Removing the brew unit and cleaning by hand .....   | 66        |
| Cleaning the interior, the inside of the appliance door and the drip catcher.....                   | 68        |
| Cleaning the appliance front.....   | 69        |
| Maintenance programmes .....  | 69        |
| Opening the Maintenance menu .....  | 70        |

# Contents

---

|  |            |
|--|------------|
| Rinsing the appliance.....   | 70         |
| Rinsing the milk pipework.....   | 70         |
| Cleaning the milk pipework.....  | 70         |
| Degreasing the brew unit.....  | 71         |
| Descaling the appliance.....   | 73         |
| <b>Automatic cleaning and descaling.....</b>                           | <b>76</b>  |
| What to ensure before and during automatic maintenance programmes..... | 76         |
| Automatic cleaning.....  | 77         |
| The Miele cleaning cartridge.....                                      | 77         |
| Replacing the cleaning cartridge.....                                  | 78         |
| Automatic descaling.....   | 79         |
| The Miele descaling cartridge.....                                     | 79         |
| Replacing the descaling cartridge.....                                 | 80         |
| Removing the descaling cartridge.....                                  | 80         |
| Fitting the descaling cartridge.....                                   | 80         |
| When not using a descaling cartridge.....                              | 81         |
| Maintenance timer.....   | 81         |
| Cancelling automatic cleaning and descaling.....                       | 81         |
| <b>Problem solving guide.....</b>                                      | <b>82</b>  |
| Messages in the display.....   | 82         |
| Unusual performance of the coffee machine.....                         | 85         |
| Faults with automatic cleaning and/or descaling.....                   | 87         |
| Unsatisfactory results.....  | 88         |
| <b>After sales service and warranty.....</b>                           | <b>91</b>  |
| Contact in case of fault.....  | 91         |
| Warranty.....  | 91         |
| <b>Accessories.....</b>  | <b>92</b>  |
| <b>Installation.....</b>   | <b>93</b>  |
| Mains water connection.....  | 93         |
| Electrical connection.....   | 94         |
| Installation dimensions.....   | 95         |
| Installation in a tall unit.....                                       | 95         |
| Installation and connections.....                                      | 96         |
| Building in the coffee machine.....                                    | 97         |
| Door opening limiters.....   | 98         |
| <b>Technical data.....</b>   | <b>100</b> |
| <b>Copyright and licences.....</b>                                     | <b>101</b> |

## Warning and Safety instructions

---

This coffee machine complies with all current local and national safety requirements. However, inappropriate use can lead to personal injury and damage to property.

Read the Operating instructions carefully before using the coffee machine. They contain important information on the safety, installation, use and maintenance of the appliance. Familiarity with these instructions will help to prevent personal injury and damage to property.

In accordance with standard IEC 60335-1, Miele expressly and strongly advises that you read and follow the instructions in “Installation”, as well as in the “Warning and Safety instructions”. Miele cannot be held liable for damage caused by non-compliance with these instructions.

Keep these instructions in a safe place and pass them on to any future owner.

# Warning and Safety instructions

---

## Correct application

- ▶ The coffee machine is intended for use in private households.
- ▶ The coffee machine is not suitable for outdoor use.
- ▶ This coffee machine must not be used at altitudes above 2,000 m.
- ▶ The machine is intended only for the preparation of drinks such as espresso, cappuccino, latte macchiato, tea etc. Any other usage is at the owner's risk.
- ▶ This appliance is not intended for use by persons (including children) with reduced physical, sensory or mental capabilities, or lack of experience and knowledge, unless they have been given supervision or instruction concerning its use by a person responsible for their safety, and are able to recognise the dangers of misuse.

## Safety with children

 Danger of burning and scalding on the dispensing spouts.

Children's skin is far more sensitive to high temperatures than that of adults.

Ensure children do not touch hot surfaces of the coffee machine or place parts of their body under the dispensing spouts.

- ▶ Install the coffee machine out of reach of children.
- ▶ Young children must not be allowed to use this appliance.
- ▶ Older children may only use the coffee machine if its operation has been clearly explained to them and they are able to use it safely. They must be aware of the potential dangers caused by incorrect operation.
- ▶ Children should be supervised when they are near the coffee machine. Do not allow them to play with it or to use the controls.
- ▶ Young children must not be allowed to clean the coffee machine. Cleaning may only be carried out by older children under the supervision of an adult.
- ▶ Remember that coffee and espresso are not suitable drinks for children.
- ▶ Danger of suffocation! Whilst playing, children may become entangled in packaging material (such as plastic wrapping) or pull the packaging material over their head, presenting the risk of suffocation. Keep packaging material away from children.



## Technical safety

- ▶ Installation must be performed by a suitably qualified and competent person. Maintenance and repairs must only be carried out by a Miele authorised technician. Unauthorised or incorrect installation work or repairs can pose considerable danger to users.
- ▶ A damaged appliance is dangerous. Check it for any visible damage. Never install or attempt to use a damaged appliance.
- ▶ Before connecting the appliance to the mains supply, make sure that the rating on the data plate corresponds to the voltage and frequency of the household supply. This data must correspond in order to avoid the risk of damage to the appliance. Consult a qualified electrician if in any doubt.
- ▶ The electrical safety of this appliance can only be guaranteed when continuity is complete between it and an effective earthing system. It is most important that this basic safety requirement is present and tested regularly and, where there is any doubt, the household wiring system should be inspected by a qualified electrician.
- ▶ Temporary or permanent operation with a self-sufficient or non-mains synchronous energy supply system (e.g. isolated networks, back-up systems) is possible. A requirement for the operation is that the energy supply system complies with all current local and national requirements that apply to stand-alone, solar and/or battery systems. The protective measures provided in the installation and in this Miele product must also be assured in their function and operation in isolated operation or in non-mains synchronous operation, or replaced with equivalent measures in the installation.
- ▶ Do not connect the machine to the mains electricity supply by a multi-socket adapter or an extension lead. These do not guarantee the safety of the appliance (e.g. danger of overheating).
- ▶ This appliance must not be installed and operated in mobile installations (e.g. on a ship).
- ▶ For safety reasons, this appliance may only be used when it has been built in.
- ▶ If the coffee machine is to be built in above another appliance, there must be a full-width, closed shelf between them (except when it is combined with a Gourmet warming drawer or a built-in vacuum sealing drawer).
- ▶ Only use the coffee machine in rooms where the ambient temperature is between +16 °C and +38 °C.

## Warning and Safety instructions

---

- ▶ A minimum installation height of 850 mm must be maintained.
- ▶ This coffee machine must not be installed behind a closed furniture door. Heat and moisture can build up behind the closed furniture door. This can result in damage to the appliance and/or furniture unit.
- ▶ Before any repair work is carried out, the appliance must be completely disconnected from the electricity supply. The appliance is only completely isolated from the electricity supply when:
  - it is switched off at the circuit breaker, or
  - the mains connection cable is disconnected from the power supply.  
Pull the plug, not the cord, to disconnect the appliance from the power supply.
- ▶ The manufacturer's warranty may be invalidated if the appliance is not repaired by a Miele approved service technician.
- ▶ Never open the outer casing of the machine. Tampering with electrical connections or components and mechanical parts is highly dangerous to the user and can cause operational faults or electric shock.

### Mains water connection

- ▶ Do not connect the coffee machine to a warm water connection.
- ▶ The non-return valve must be easily accessible when the coffee machine is built in.
- ▶ The protective sleeve of the water inlet hose must not be damaged or become kinked. This will cause it to leak.
- ▶ The integrated water protection system offers protection from water damage, provided the following conditions are met:
  - The machine is correctly installed (connected to the electricity supply) and plumbed in.
  - The machine is properly maintained and parts are replaced where it can be seen that this is necessary.
  - The tap has been turned off when the appliance is not going to be used for a longer period of time (e.g. during holidays).

## Correct use

 Danger of burning and scalding on the dispensing spouts. The liquids and steam dispensed are very hot.

Keep well away from the area underneath the spouts when hot liquids and steam are being dispensed.

Do not touch hot components.

Hot liquid or steam could spatter from the spouts. Ensure that the central spout is clean and fitted correctly.

If there is a cup or container underneath the central spout, make sure that you remove this before opening the appliance door.

Water in the drip tray can also be very hot. Take care when emptying it.

 Risk of injury to the eyes!

Never look directly at the lighting or use optical instruments (magnifying glass or similar) to look at it.

► Please note the following regarding water:

- The water quality must conform to the requirements for drinking water in the country in which the coffee machine is being used.
- When using the water container: Only use cold, fresh tap water to fill the water container. Hot or warm water or other liquids can damage the coffee machine.
- Change the water every day to prevent a build-up of bacteria.  
When using mains water: Empty the water container once a day.
- Do not use carbonated water.

► Only put roasted coffee beans in the bean container. Do not put coffee beans containing additives or ground coffee in the bean containers.

► Do not fill the bean container with any type of liquid.

► Do not use green (unroasted) coffee beans or mixtures of coffee beans which contain green coffee beans. Green coffee beans are very hard and still contain residual moisture. These can damage the coffee machine grinder as soon as grinding begins.

► Do not use coffee beans which have been treated with caramel, sugar or other substances. Sugar will damage the coffee machine.

## Warning and Safety instructions

---

- ▶ If decaffeinated coffee beans are used after dispensing a drink with caffeinated beans, there may still be residues from the caffeinated beans in the grinder or brew chamber. Discard the first coffee drink when using decaffeinated coffee.
- ▶ Only use milk without additives. Additives in milk usually contain sugar and this will stick to the milk pipework.
- ▶ If using cow's milk, only use pasteurised milk to prevent a build-up of bacteria in the appliance.
- ▶ When making tea, please follow the instructions on the packaging.
- ▶ Do not place flaming alcohol mixtures underneath the central spout. The flames could ignite plastic components and cause them to melt.
- ▶ Do not swing from or hang anything on the appliance door when it is open as this could damage the hinges on the coffee machine.
- ▶ The machine must not be used for cleaning objects.

### Accessories and spare parts

- ▶ Miele can only guarantee the safety of the appliance when original Miele spare parts are used. Faulty components must only be replaced by original Miele spare parts.
- ▶ Only use original Miele spare parts and accessories. If other spare parts and accessories are used, warranty, performance and/or product liability claims will be invalidated and Miele cannot accept liability.
- ▶ Miele will guarantee to supply functional spare parts for a minimum of 10 years and up to 15 years following the discontinuation of your coffee machine.

## Cleaning and care

- ▶ Clean the coffee machine and the milk flask daily, particularly before using for the first time.
- ▶ All parts of the milk system need to be cleaned thoroughly and regularly. Milk contains bacteria which proliferate rapidly with inadequate cleaning.
- ▶ Avoid spillage on appliance connectors.
- ▶ If you do not utilise automatic descaling and cleaning, you will need to carry out the maintenance programmes for cleaning the milk pipework, the brew unit and descaling the coffee machine manually on a regular basis. Miele cannot be held liable for damage resulting from not cleaning and/or descaling the machine, using the wrong cleaning/descaling agent or an unsuitable concentration.
- ▶ Do not clean the machine with a steam cleaner or immerse it in water as this will damage the machine. Steam or water could reach the electrical components and cause a short circuit.
- ▶ Used coffee grounds should be disposed of with the organic rubbish or on the compost heap. Do not empty them down the sink, as they could block it.

## **The following applies to appliances with stainless steel surfaces:**



- ▶ Do not adhere stickers, adhesive tape or any other adhesive materials to stainless steel surfaces. The coating on the stainless steel surfaces will become damaged and lose its protective properties against soiling.
- ▶ Stainless steel scratches very easily and even magnets can cause damage to the surface.

# Guide to the appliance

---

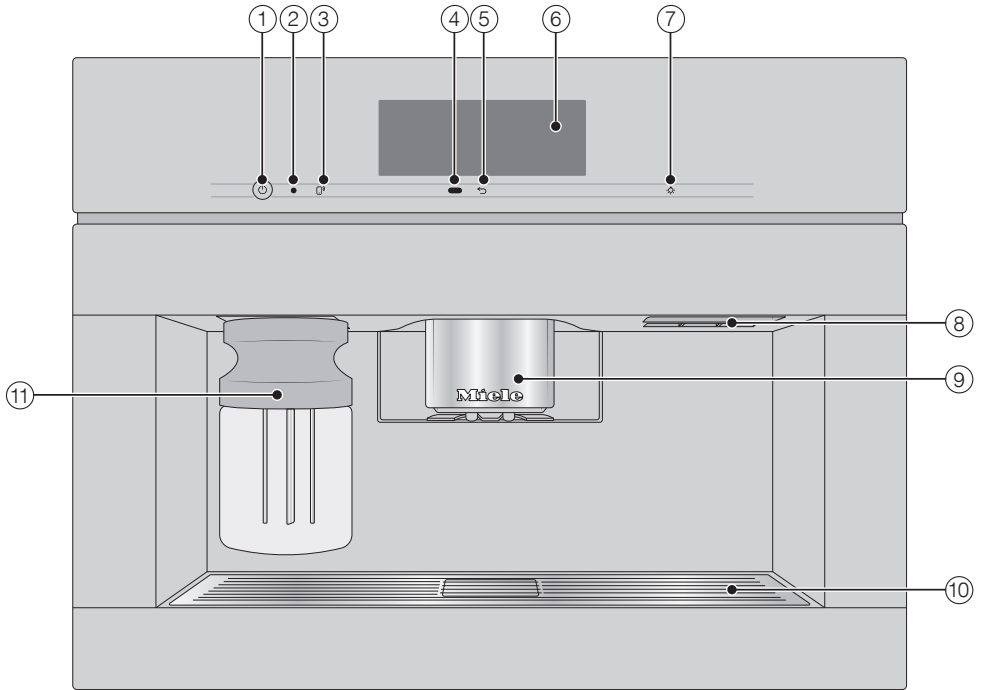
## Exterior view



- ① On/Off ① sensor
- ② Optical interface (for Miele Service technicians only)
- ③ MobileStart  sensor
- ④ Proximity sensor
- ⑤ “Back”  sensor
- ⑥ Touch display
- ⑦ “Lighting”  sensor control
- ⑧ Door handle
- ⑨ Automatic height-adjustable central spout with lighting
- ⑩ Drip tray cover
- ⑪ Milk flask

## Interior view

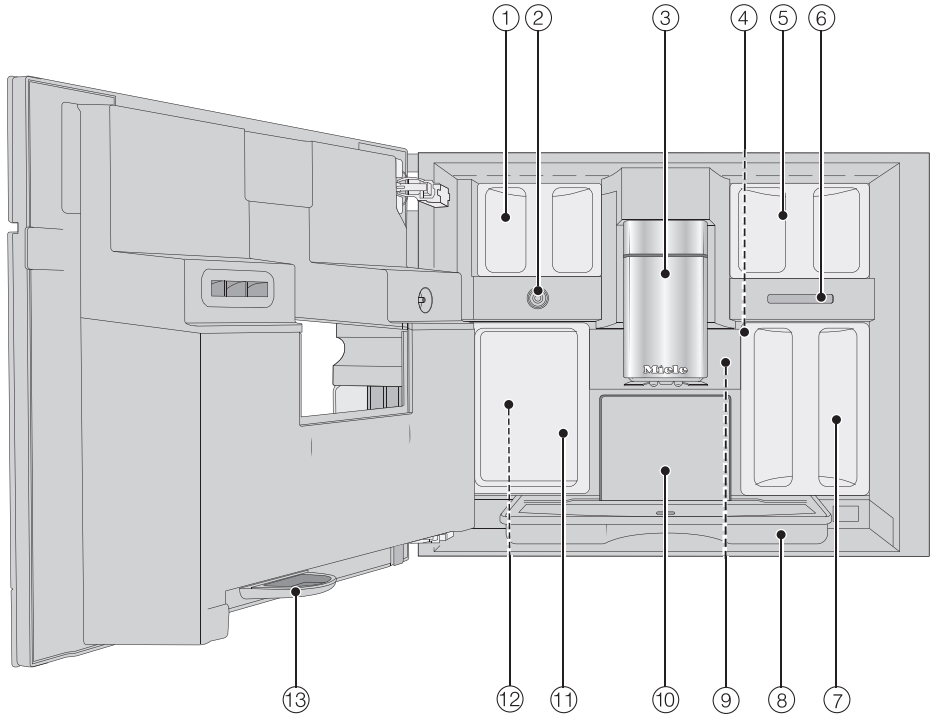

- ① Bean containers (Type A and Type C)
- ② Milk valve
- ③ Automatic height-adjustable central spout with lighting
- ④ Grinder setting
- ⑤ Bean containers (Type B)
- ⑥ Fan outlet
- ⑦ Water container
- ⑧ Drip tray with lid
- ⑨ Brew unit
- ⑩ Waste container
- ⑪ Maintenance container
- ⑫ Holders for cleaning and descaling cartridges (including plug)
- ⑬ Drip catcher

# Guide to the appliance

## Milk flask

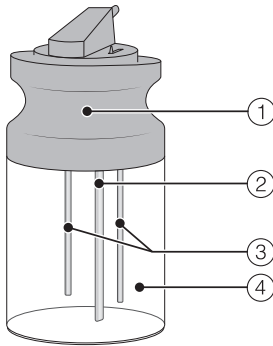

- ① Lid
- ② Milk suction tube
- ③ Milk level sensor rod
- ④ Glass milk flask

## Central spout with cup rim sensor

The central spout with cup rim sensor features automatic adjustment. By means of this spout adjustment, at the beginning of drink preparation the central spout moves down automatically and the cup rim sensor stops it at the optimum height for the cups or glasses being used.

The height of the central spout with cup rim sensor **cannot** be manually adjusted.

When the coffee machine is switched off, the central spout moves to a medium height.

When a maintenance programme is being carried out, the central spout will move to the height of the cleaning container or into a lower maintenance position.

Ensure the central spout is in either the upper or middle position before opening the door.



## Symbols in the display

In addition to text, symbols are shown in the display.

| Symbol | Explanation  |
|--------|--|
|        | This symbol indicates that there is additional information and advice about using the coffee machine. Select <i>OK</i> to confirm the messages.  |
|        | This symbol indicates the “Settings” menu and the “Language” menu option.  |
|        | The symbol is displayed when the system lock is switched on. The controls are locked.  |
|        | This symbol and the desired switching on time appear in the display up to 23:59 hours before the coffee machine is due to switch on if the On at timer and the time of day display are activated.              |
|        | This symbol appears during the Clean the milk pipework maintenance programme and during automatic cleaning. This symbol can also be found on the water container: fill up to this mark with water.             |
|        | This symbol is displayed while the appliance is being descaled. This symbol can also be found on the water container: fill up to this mark.  |
|        | This symbol and a fault code will appear if a fault occurs.  |
|        | If Miele@home is activated for the coffee machine, the Wi-Fi connection is indicated with these symbols. The symbols indicate the strength of the Wi-Fi connection in gradations from strong to not connected. |
|        | The “Remote control” symbol appears if Miele@home has been set up for the coffee machine and the Remote control   On setting has been selected.  |
|        | The “SuperVision” symbol appears if Miele@home has been set up for the coffee machine and the SuperVision   SuperVision display   On setting has been selected.  |

# Operating principles

---

## Touch display

The sensitive touch display can be scratched by pointed or sharp objects, e.g. pens.

Only touch the display with your fingers.

The touch display is divided into multiple areas.

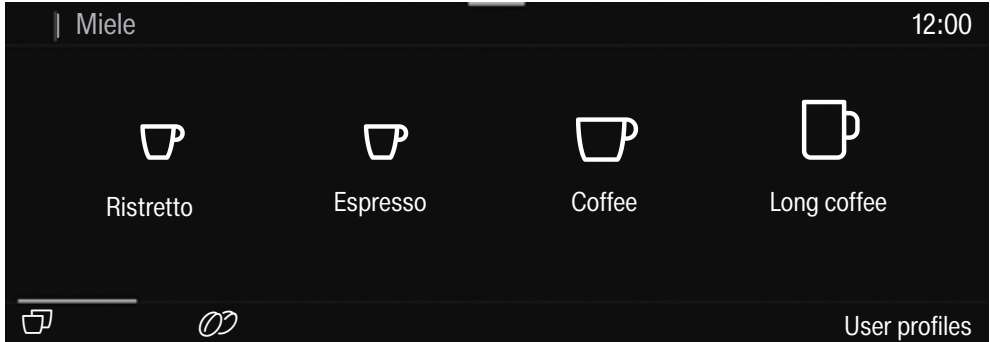

The menu path appears on the left of the **header**. If you touch a menu name in the header, the display will switch to that menu. To switch to the start screen, touch .

The time of day is shown on the right of the header. Additional symbols may also appear, e.g. TeaTimer .

The current menu and menu options are shown in the **centre**. You can scroll to the right or left by swiping your finger across the display to the right or left.

Depending on the menu, various operating options appear in the **footer**, e.g. DoubleShot , Save or OK.

## Operating actions

All selectable options are displayed in either white or black, depending on which colour scheme has been selected.

Each touch of a possible selection colours the relevant character (word and/or symbol) **orange**.

### Selecting a menu option

- Touch the desired menu option or value in the touch display.

### Scrolling

You can scroll left or right.

- Swipe across the screen. To do this, place your finger on the touch display and swipe it in the direction you want.

The bar at the bottom of the display shows you your position in the current menu.

### Exiting a menu

- Touch the ↵ sensor. Alternatively, you can touch the upper level menu name in the menu path.

Entries made before this which have not been confirmed with *OK* will not be saved.

**Useful tip:** If you touch the ↵ sensor three times in succession, you will return to the drinks menu.

### Entering numbers with the roller

- Swipe the roller up or down until the number you want is located in the centre and coloured orange.
- Confirm with *OK*.

# Operating principles

---

## Entering numbers using the numerical keypad

- Touch the orange coloured value in the centre until the numerical keypad appears.

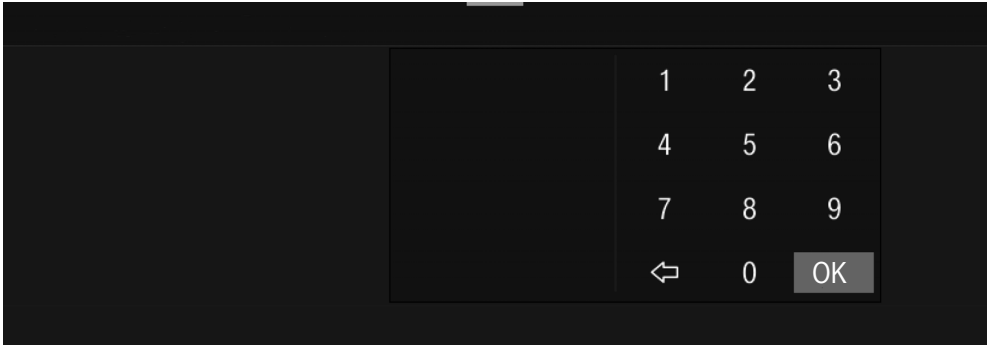

- Select the desired value: as soon as a valid value has been entered, *OK* is highlighted green. Use the ↶ arrow to delete the last entered number.
- Confirm with *OK*.

## Entering a name

Letters are entered using a keyboard. It is best to select short, memorable names.

- Touch the letters or characters you want.

**Useful tip:** Use the ↶ arrow to delete the last entered character.

- Touch *Save*.

## Displaying a context menu

In some menus you can display a context menu, e.g. to configure drinks.

- Touch and keep your finger on a drink name, for example, until the context menu opens.
- Touch the touch display outside of the menu window to close the context menu.

## Moving entries

You can change the order of the entries in the drinks menu to *User profiles* and *MyMiele*.

- Touch and hold an entry until the context menu appears.
- Select *Move*.

An orange frame will appear around the entry.

- Touch the highlighted entry and hold your finger on the display. Drag the entry to the required position.

## Help

Context-sensitive help is available for certain functions. Help appears on the bottom line.

- Touch Help to display information in text and pictures.
- Touch Close to return to the previous menu.

## Pull-down menu

In the pull-down menu you will find, for example, the schematic representation of the bean containers and the Expert mode.

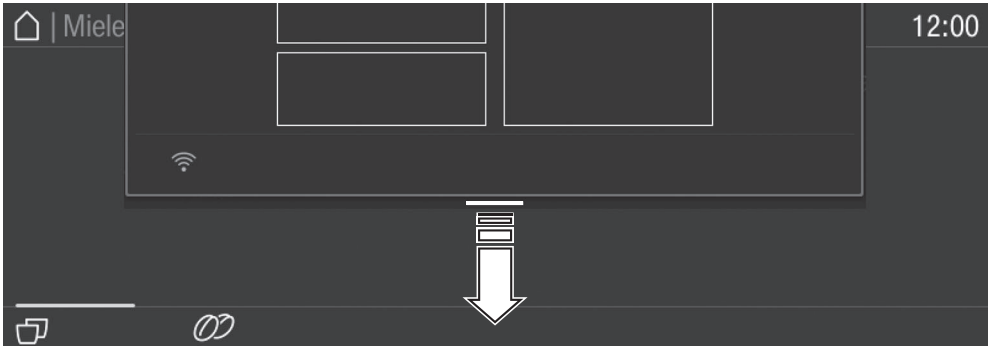

- Touch the top edge of the screen on the orange line and drag down with your finger.

Active settings are highlighted in orange.

- To close the pull-down menu, touch the display outside of the menu window or slide the pull-down menu up.

Your coffee machine is equipped with an integrated Wi-Fi module.

Before installing the coffee machine in its final location, ensure the signal strength of your Wi-Fi network is sufficient.

To use this feature, you will need:

- a Wi-Fi network
- the Miele App
- a Miele user account, which can be created via the Miele App

The Miele App will guide you through the process of connecting your coffee machine to your home Wi-Fi network.

Once your coffee machine is connected to your Wi-Fi network, you can use the Miele App, for example, to carry out the following activities:

- Install software updates
- Call up information on the operating status of your coffee machine
- Change the settings of your coffee machine
- Operate your coffee machine remotely

Connecting your coffee machine to your Wi-Fi network will increase energy consumption, even when the coffee machine is switched off.

## Availability of the Wi-Fi connection

The Wi-Fi connection shares a frequency range with other appliances (including microwave ovens and remote control toys). This may result in sporadic or even complete connection failures. Therefore, a constant availability of featured functions cannot be guaranteed.

## Miele@home availability

The ability to use the Miele App depends on the availability of the Miele@home service in your country.

The Miele@home service is not available in every country.

For information about availability, please visit [www.miele.com](http://www.miele.com).

## Miele App

You can download the Miele App from the Apple App Store® or the Google Play Store™ free of charge (only functional in selected countries).



# Before using for the first time

## Before using for the first time

- Connect the coffee machine to the mains water supply and the mains electricity supply.
- Install the coffee machine.
- Remove any protective foil and stickers from the machine. Exception: Please do not remove any labels (e.g. the data plate) which are visible when you pull out the lower panel.
- Remove the protective foil from the drip tray cover.
- Clean the water container, the bean containers and the central spout.

Before using the appliance for the first time, you will need:

- Miele cleaning cartridge
- Miele descaling cartridge

## Switching on for the first time

- Touch the On/Off ⓘ sensor.

## Selecting the display language

- Select the required display language.

You might also be asked for your location.

The choice of location determines how the time of day is displayed, e.g. in the 12 or 24-hour format, as well as how units are displayed.

## Setting up the network (Miele@home)

To receive software updates and operate the coffee machine via the Miele App on your mobile device, you can connect your coffee machine to your home Wi-Fi network.

The following appears in the display during commissioning: Set up Miele@home?

**Useful tip:** You can also set up Miele@home at a later time by scanning the QR code on the inside of the appliance door (see “Setting up Scan & Connect”). In this case, select Skip.

- Make sure that the signal of your Wi-Fi network is sufficiently strong in the place where you want to set up your coffee machine.
- Touch Continue.
- Select the connection method you wish to use.
- Follow the instructions provided in the coffee machine display and in the Miele App.

Connection successfully established appears in the display.

Any new software that is available for your coffee machine will be downloaded via RemoteUpdate the next time the appliance is switched on. In this case, you will be notified that you can install the new software (see “RemoteUpdate”).

Networking increases the energy consumption of the coffee machine.

- Touch Continue to proceed with commissioning.

## Setting the date

- Set current the date.
- Confirm with OK.

## Setting the time of day

- Set the current time of day.
- Confirm with OK.

## Before using for the first time

If the coffee machine has been connected to a Wi-Fi network and is signed into the Miele App, the time will be synchronised based on the location setting in the Miele App.

### Setting the water hardness level

Contact your local water supplier to find out your local water hardness range if necessary.

See “Settings - Water hardness” for more information.

- Enter the local water hardness level (in °dH) and confirm with *OK*.

### Selecting the water supply (Mains water)

The coffee machine is intended to be operated with a mains water connection. You can select from one of the following water supply options:

- **On:** The water container is automatically filled with fresh tap water via the mains water connection.
- **Off:** You need to fill the water container manually. A message appears in the display to inform you of this.

- Select the desired option.

### Setting up automatic cleaning and descaling

Information about automatic cleaning and descaling is shown in the display.

- Confirm with *OK*.

**Useful tip:** Touch *Help* to get illustrated instructions in the display.

### Fitting the cleaning cartridge

You will now be prompted to fit a cleaning cartridge.

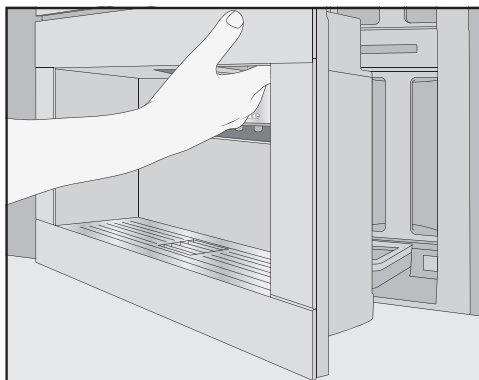

- Open the appliance door.

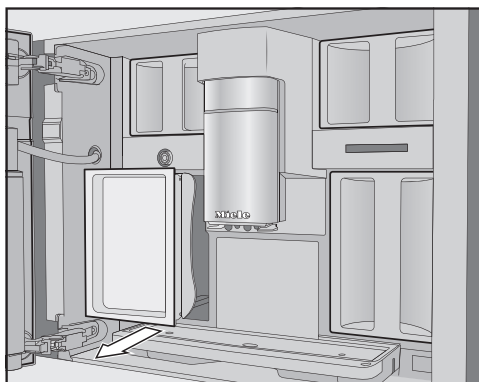

- Remove the maintenance container on the left.

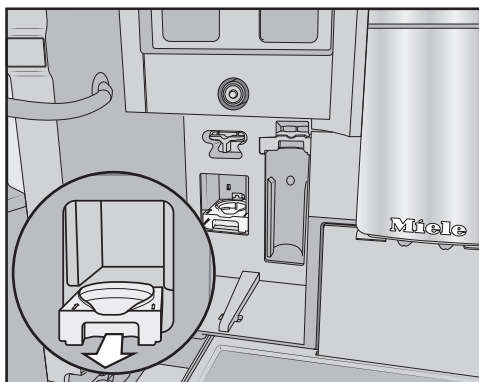

- Pull the cleaning cartridge holder forwards and take it out.



## Before using for the first time

- Remove the cleaning cartridge from its packaging.
- Unscrew the cap.

The cap is no longer required.

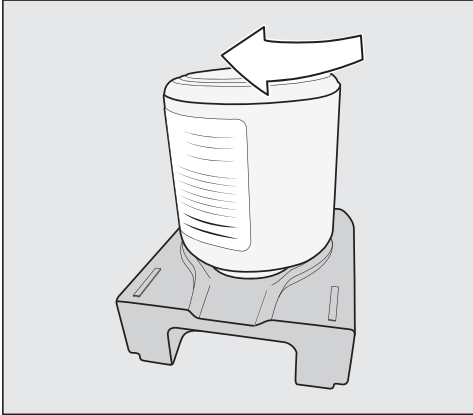

- Screw the cleaning cartridge into the holder upside down.
- Push the holder with the cartridge into the coffee machine until it clicks into place.

### Fitting the descaling cartridge

- Remove the descaling cartridge from its packaging.

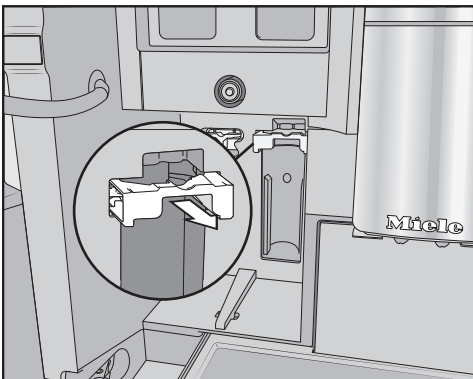

- Pull the descaling cartridge holder forwards.

- Fit the descaling cartridge and push it upwards as far as it will go.
- Push the descaling cartridge holder back in.
- Refit the maintenance container.
- Close the appliance door.

The descaling cartridge will fill with water the next time the machine is switched off.

Wait until the coffee machine switches itself off. Do not force the machine to switch off.

### Changing the start time

If the cleaning and descaling cartridges are fitted, a message about the set start time of automatic cleaning and automatic descaling will appear.

- If you want to change the start time, touch **Timer**.
- Select the time you want.
- Confirm with **OK**.

You can change the start time for automatic cleaning and descaling at any time.

### Selecting the Performance mode

You can select the appropriate Performance mode to suit your personal preferences (see “Adjusting settings – Performance mode”).

- **Eco mode:** this mode consumes the least amount of energy (default setting).
- **Barista mode:** this mode is optimised for perfect coffee enjoyment.
- **Latte mode:** in this mode, milk-based drinks can be prepared within a much shorter space of time.

## Before using for the first time

- Select the Performance mode you want.

Selecting a Performance mode other than Eco mode increases the energy consumption of the coffee machine.

The coffee machine is now successfully set up for use. You can now fill the bean system.

### Setting up the bean system

After setting up the coffee machine, you will be prompted to set up the bean system. The coffee machine will assist you when first filling and naming the bean containers.

- Touch Yes.

If you select No, the assistant for setting up the bean system will not be shown again.

### Filling the bean containers

There are two bean container drawers at the top right and left of the coffee machine.

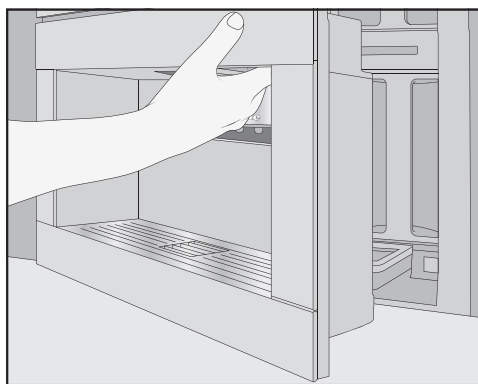

- Open the appliance door.

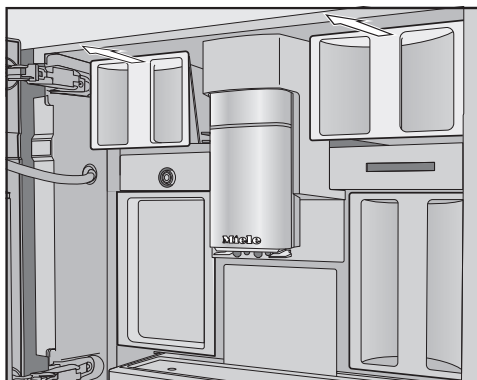

- Pull out the coffee bean containers and remove their lids.
- Fill the containers with roasted coffee beans.
- Close the bean containers with their respective lids.
- Push the bean containers back into the coffee machine. Close the appliance door.

**Useful tip:** Make a note of each type of bean.

After filling the bean containers, you can now name the types of beans.

### Naming the types of beans

The 3 bean containers are shown in the display as follows and are pre-named.

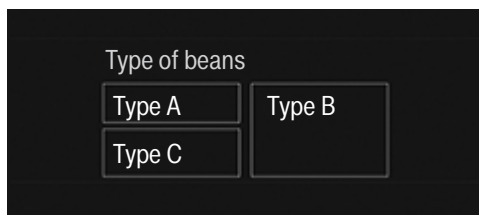

If you rename the bean containers, please note the following:

- It is best to select short, memorable names.

## Before using for the first time

- If you are using the same type of beans in two or three bean containers at the same time (for instance, because you only use one type of bean), make sure you name them in exactly the same way.

Name type of beans for bean container? appears in the display and Type A is highlighted orange.

- Touch **Yes**.

The editor will open in the display.

- Enter the name you want for the bean container.
- Touch **Save**.
- Now name the other two bean containers.

Allocate type <Type XY> appears in the header line.

### Allocating bean types

Allocate the desired coffee drinks to the individual bean types.

- Select the drinks that are to be prepared with this type of bean.

The selected coffee drinks will be highlighted in orange.

- Confirm with **OK**.

The next type of bean is now allocated and any unallocated coffee drinks are displayed.

- Select the drinks that are to be prepared with this type of bean.
- Confirm with **OK**.

Any remaining drinks which have not been selected will be allocated to the third bean type.

You have set up the bean system and you can now prepare drinks.

**Useful tip:** All coffee drinks are highlighted if you touch **All drinks**. Unwanted drinks can be deselected.

If you do not allocate bean containers to the drinks, you will be asked during drink preparation which type of bean you want to use.

To ensure that any coffee residues from the factory testing process are removed from the brewing system, please throw away the first two cups of coffee when using the coffee machine for the first time.

## Bean system

Coffee or espresso can be made from whole roasted coffee beans which are freshly ground for each portion. Your coffee machine has a bean system with three bean containers which can be filled with different types of beans or even just one type. You can allocate bean types to individual coffee drinks as you wish. Alternatively, you can create profiles with your own coffee drinks and allocate other bean types to these drinks which are different to the Miele profiles.

 Risk of damage to the grinder due to incorrect operation.

The coffee machine will be damaged if the bean container is filled with unsuitable substances such as liquids, ground coffee or coffee beans treated with sugar, caramel or similar. In addition, green (unroasted) coffee beans or mixtures of coffee beans which contain green coffee beans can damage the grinder. Green coffee beans are very hard and still contain residual moisture. These can damage the coffee machine grinder as soon as grinding begins.

Only put roasted coffee beans in the bean container.

If decaffeinated coffee beans are used after dispensing a drink with caffeinated beans, there may still be residues from the caffeinated beans in the grinder or brew chamber. Please be aware that minimal residues of caffeinated beans may be present in the next drink that you make.

## Changing bean system settings (Type of beans)

The drinks menu is displayed.

- Touch the ↶ sensor.
- Select Settings.
- Select Type of beans.

The schematic representation of the bean containers will be displayed.

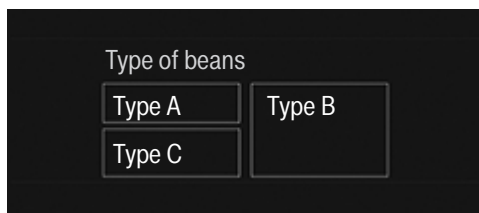

- Select a bean type.

You can now change the name of the type of bean or change the allocation.

**Useful tip:** If you want to allocate another type of bean to a coffee drink, you can also do this under "Change parameters" (see "Parameters - Type of beans").

### Renaming type of beans

If you rename the type of beans, please note the following:

- It is best to select short, memorable names.
- If you are using the same type of beans in two or three bean containers at the same time (for instance, because you only use one type of bean), make sure you name them in exactly the same way.

- Touch Change name.

The editor will open in the display.

- Enter the name you want.
- Touch Save.

If you give identically named types of beans different names, you will then need to allocate coffee drinks to the newly named beans.

## Changing the allocation of the bean containers

If you have created additional Profiles with coffee drinks to the Miele standard profile, the bean types can be individually allocated to individual drinks in each Profile.

- Touch **Change allocation**.

If you have set up one or more profiles and saved at least one coffee drink, first select the profile.

- Select the profile for which you want to allocate the type of beans.

All coffee drinks will be listed. The already allocated drinks will be highlighted in orange.

- Change the allocation as required.
- Confirm with *OK*.

**Useful tip:** If you touch *All drinks*, you will highlight all coffee drinks and you can deselect the ones you do not want.

If you do not allocate a type of bean, you will be asked what type of bean you want to use for the coffee as you make it.

## Filling the water container

⚠ Risk to health due to contaminated water.

Bacteria can develop in water which has been sitting in the water container for too long and is a risk to your health. The taste of water sitting in the inlet hose can also be affected if drinks have not been prepared for a long time.

Change the water in the water container **every day**.

Pour out the water from the water container if a drink has not been prepared for a long time.

If the coffee machine is connected to a plumbed water supply and this setting is selected, the water container fills automatically when the machine is switched on.

The water container can be filled manually at any time.

⚠ Risk of damage due to incorrect operation.

Unsuitable liquids such as hot or warm water or other liquids can damage the coffee machine.

Carbonated water leaves too much limescale in the coffee machine.

If filling the water container manually:  
Only use fresh, cold tap water.

- Open the appliance door.

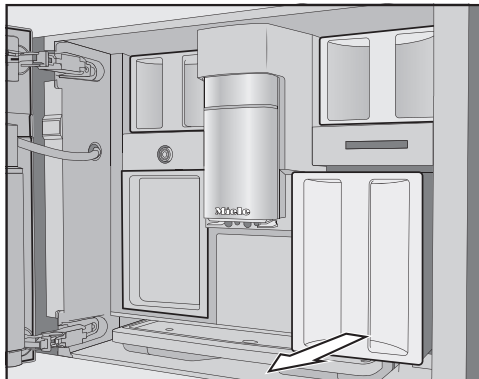

- Pull the water container out to remove it.
- Fill the water container with fresh, cold drinking water up to the *max.* marker.
- Push the water container into the appliance.
- Close the appliance door.

### Switching the coffee machine on

- Touch the On/Off ① sensor.

The coffee machine heats up and rinses the pipework. Hot water will run out of the central spout.

You can now make drinks.

If the coffee machine is already at operating temperature, rinsing will not take place.

### Switching the coffee machine off

- Touch the On/Off ① sensor.

If coffee has been dispensed, the coffee machine will rinse the coffee pipework automatically before switching off.

While dispensing a drink or during maintenance processes, moisture builds up in the coffee machine. Once a drink has been dispensed or the machine has been switched off, the internal fan will continue to run until the interior is sufficiently dehumidified. You will hear an accompanying noise.

### Preparing for extended disuse

If the coffee machine is not going to be used for more than 3 days, such as during a holiday, proceed as follows:

- Empty the drip tray, the waste container and the water container.
- Clean all parts thoroughly, including the brew unit and appliance interior.
- Switch the coffee machine off.

# Making drinks



Danger of burning and scalding on the dispensing spouts.

The liquids and steam dispensed are very hot and can cause scalding.

Keep well away from the area underneath the spouts when hot liquids and steam are being dispensed.

Do not touch hot components.

## Coffee

### Coffee drinks in detail

You can use your coffee machine to prepare the following coffee specialities:

- **Ristretto** is a strong, concentrated espresso. It is prepared with the same amount of coffee as for an espresso but with much less water.
- **Espresso** is a strong aromatic coffee with a thick hazelnut brown coloured froth – known as the crema – on top. We recommend using espresso roasted coffee beans to make an espresso.
- **Coffee** differs from espresso by the increased amount of water and the roast of the beans. We recommend using coffee beans with the appropriate roast to make the coffee.
- **Long coffee** is a coffee with considerably more water.
- **Long black** is made with hot water and two shots of espresso.
- **Caffè Americano** consists of equal proportions of espresso and hot water. The espresso is made first, then the hot water is dispensed.
- **Cappuccino** consists of approx. 2/3 milk froth and 1/3 espresso.

- **Latte macchiato** consists of 1/3 each of hot milk, milk froth and espresso.
- **Caffè latte** consists of hot milk and espresso.
- **Cappuccino Italiano** has the same proportions of milk froth and espresso as a cappuccino. The difference is that the espresso is added first and then the milk froth.
- **Espresso macchiato** is an espresso with a small amount of milk froth on top.
- **Flat white** is a special variation of the cappuccino: a much greater amount of espresso compared to milk froth creates an intensive coffee aroma.
- **Café au lait** is a French coffee speciality made from coffee and milk froth. Café au lait is normally served in a bowl.

**Hot milk or milk froth** can also be made separately.

### Milk and milk alternatives

Milk containing added sugar or plant-based milk alternatives, e.g. soy drinks, can clog up the milk tube and the rest of the milk pipework. Residues from unsuitable liquids may adversely affect correct preparation. Do not use milk with additives.

Animal milk naturally contains bacteria.

If using animal milk, make sure that it has been pasteurised, e.g. pasteurised cow's milk.

You can prepare hot milk and milk froth with cow's milk or with plant-based milk alternatives. Depending on the milk



used, the consistency of the milk froth can vary greatly. Not every type of milk is well suited to frothing.

After the heating-up phase, the milk will be drawn up into the central spout where it is heated by steam and also frothed for drinks requiring milk froth.

**Useful tip:** Using cold cow's milk (< 10 °C) with a protein content of at least 3% will produce the perfect milk froth.

You can select milk with a fat content according to preference. With full cream milk (at least 3.5% fat), the milk froth will be slightly creamier than with low-fat milk.

Plant-based milk alternatives - abbreviated as "milk alternatives" in the following - contain other substances than cow's milk, for example. Due to natural settling, thickening can occur in milk alternatives. During the preparation of hot milk or milk froth, such thickening can impede the intake of milk alternatives.

Stir milk alternatives thoroughly directly before drink preparation.

Do not shake milk alternatives. Shaking causes an unwanted formation of froth in the packaging and impairs preparation.

**Useful tip:** Manually rinse the milk pipework immediately after preparation.

## Filling and fitting the milk flask

Milk is **not** cooled in the milk flask.

The milk can spoil if left unchilled in the milk flask for a long period of time (depending on type of milk).

Do not leave cow's milk in particular in the milk flask out of the fridge for a long period of time.

Please follow the manufacturer's instructions concerning the storage life of the milk being used.

If you have not made any milk drinks for a while, rinse the milk system thoroughly before making the first drink.

**Useful tip:** Use cold milk (< 10 °C) to produce a good quality milk froth.

- If you are using milk alternatives, be sure to stir them thoroughly first. To ensure the best preparation, milk alternatives must be stirred and not shaken.
- Fill the milk flask with milk up to a maximum of 2 cm below the rim.
- Seal the milk flask with the lid.

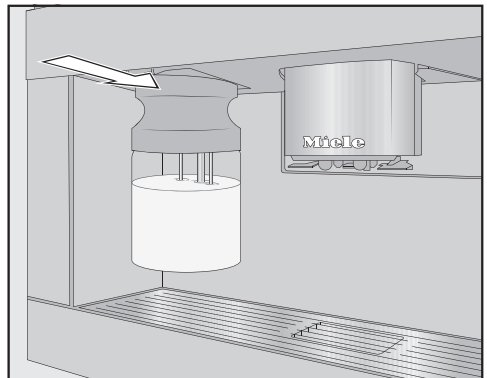

- Push the milk flask into the coffee machine until it clicks into place.

## Making drinks



**Useful tip:** The milk flask is easier to remove again with two hands.

### Making a coffee drink

If decaffeinated coffee beans are used after dispensing a drink with caffeinated beans, there may still be residues from the caffeinated beans in the grinder or brew chamber.

Please be aware that minimal residues of caffeinated beans from the previous drink may be present in the next drink that you make.

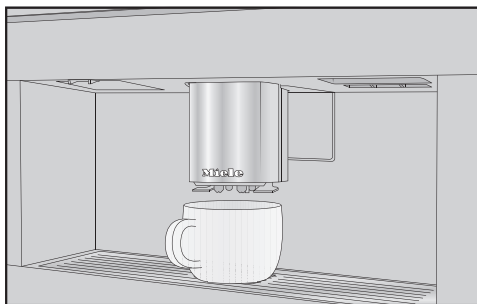

- Place a suitable cup or glass underneath the central spout.
- If you want to make a coffee with hot milk or milk froth, prepare the milk flask and insert it in the machine.
- Select a coffee drink.

Preparation will begin and the coffee will be dispensed into the cup or glass from the central spout.

**Useful tip:** If you have dispensed a coffee with milk, manually rinse the milk pipework after preparation.

### Cancelling preparation

- Touch Stop or Cancel.

### DoubleShot

Select the DoubleShot  function to make a particularly strong and aromatic coffee. In this case, more coffee beans will be ground and brewed halfway through brewing. Due to the reduced extraction time, fewer unwanted aromas and bitter substances are released.

DoubleShot can be activated for all coffee drinks except "Ristretto" and "Long black".

### Making a DoubleShot of coffee

The  symbol is displayed during preparation of coffee drinks.

- Touch the  symbol immediately before or after you have started making a drink.

Preparation starts and the  symbol is highlighted orange in the display. Two portions of coffee beans will be ground and brewed.

### Making two portions

You can also dispense two portions of a drink into one large cup or dispense two portions into two cups at the same time.

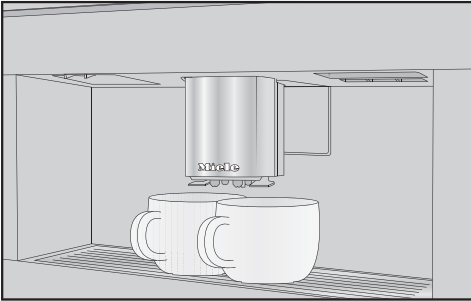

- Place one cup under each of the coffee spouts.
- Touch the ☐ symbol immediately before or after you have started making a drink.

Preparation starts and the ☐ symbol is highlighted orange in the display. Two portions of the desired drink will be dispensed.

## Preparing a pot of coffee

You can make several cups of coffee one after the other automatically with the Coffee pot function (max. 1 litre).

The drinks menu is displayed.

**Useful tip:** Before starting Coffee pot, ensure the bean containers and the water container are sufficiently filled.

- Place a sufficiently large container under the central spout.
- Select Coffee pot.

**Useful tip:** You will find Coffee pot at the end of the drinks menu.

- Select the number of portions you want to dispense (3 to 8).
- Follow the instructions in the display.

Each portion of coffee will be ground, brewed and dispensed individually. The display will inform you about the progress.

You can interrupt preparation at any time.

- Touch Cancel.

## Tea

If the dispensing temperature is too high or too low or if the brewing time is too short or too long, this can affect the flavour of your tea.

Follow the instructions provided by the manufacturer of the tea you are making.

This coffee machine is not intended for commercial or scientific purposes. Dispensing temperatures given are approximate and can vary according to ambient conditions. A change in temperature of approx. 2 °C makes a difference.

To make tea, you can select from the following options:

- **Japanese tea** is a high quality green tea and has a delicate, fresh, “green” flavour.  
Dispensing temperature: approx. 65 °C; brewing time: approx. 1.5 minutes
- **White tea** is a green tea where only the young buds of the tea plant, which are still white, are used and processed very gently. White tea has a particularly mild flavour.  
Dispensing temperature: approx. 70 °C; brewing time: approx. 2 minutes
- **Green tea** gets its green colour from the leaves of the tea plant. The tea leaves are processed gently in different ways – either roasted or steamed – depending on the region. Green tea can be infused multiple times.

# Making drinks

---

Dispensing temperature:  
approx. 80 °C; brewing time:  
approx. 2.5 minutes

- **Black tea** gets its dark colour and typical flavour from the fermentation of the tea leaves. Black tea can be drunk with a little lemon or with milk. Dispensing temperature: approx. 97 °C; brewing time: approx. 3 minutes
- **Chai latte** has its origins in the traditional Ayurveda medicine as a black tea with typically Indian spices and milk. The milk mellows the spices and tops off the flavour experience. Dispensing temperature: approx. 97 °C; brewing time: approx. 3 minutes

- **Herbal tea** is an aromatic infusion drink made up of dried leaves or fresh parts of plants. Dispensing temperature: approx. 97 °C; brewing time: approx. 8 minutes

- **Fruit tea** consists of dried pieces of fruit and/or parts of plants, e.g. rose hip. The flavour varies depending on the plants used and their blend. Many fruit teas are also flavoured. Dispensing temperature: approx. 97 °C; brewing time: approx. 8 minutes

The preset dispensing temperature varies depending on the type of tea. The respective dispensing temperatures are recommended by Miele for making these types of tea.

Whether you use loose tea leaves, blended tea or tea bags depends on your own personal preferences.

The amount of tea to use varies from one type of tea to the next. Always follow the recommendations of the

manufacturer on the packaging or of the supplier. You can adjust the amount of water according to the type of tea and the size of the cup (see “Changing the portion size”).

## Making tea

The drinks menu is displayed.

- Pour loose tea into a tea filter or similar.
- Place the tea filter or a tea bag in the tea cup.
- Place the tea cup under the central spout.
- Select the type of tea from the display.

Hot water will be dispensed into the cup.

If you have selected TeaTimer | Automatic, the TeaTimer for the brewing time will start automatically.

Alternatively, you can also start the TeaTimer manually.

A buzzer will sound and the ⏳ symbol will flash after the brewing time has elapsed.

- Touch ⏳ to confirm that the brewing time has elapsed.

The TeaTimer has elapsed.

- Now remove the tea leaves or the tea bag.

## Starting the TeaTimer manually

- Make a tea.
- Touch TeaTimer.

The editor opens with a suggested brewing time.

- Change the brewing time if necessary.
- Confirm with *OK*.

A buzzer will sound and the ⏰ symbol will flash after the brewing time has elapsed.

- Touch ⏰ to confirm that the brewing time has elapsed.

The TeaTimer has elapsed.

- Now remove the tea leaves or the tea bag.

## Preparing a pot of tea

You can use the Teapot function to dispense a larger quantity of water for making tea (max. 1 litre). The selected type of tea determines the preset temperature.

The drinks menu is displayed.

**Useful tip:** Before you start making a teapot, ensure the water container is sufficiently filled.

- Place a sufficiently large container under the central spout.
- Select the teapot option you want.
- Select the number of portions you want to dispense (3 to 8).

You can interrupt preparation at any time.

- Touch Cancel.

## Preparing warm and hot water

You can select from the following options:

- Hot water (approx. 90 °C)
- Warm water (approx. 65 °C)

The drinks menu is displayed.

- Place a suitable cup or glass underneath the central spout.
- Select warm or hot water.

Dispensing will start.

## Changing the portion size

The drinks menu is displayed.

- Place the desired cup under the central spout.
- Touch and hold the required drink until the context menu opens.
- Touch Portion size.

The drink will be made. Save will appear in the display as soon as the minimum dispensing amount is reached.

- When the cup is filled up to the level you want, touch Save.

If the maximum amount is reached, preparation stops and the maximum possible amount is saved.

If you want to change the portion size for coffee drinks made with milk or hot water, the ingredients (components) which make up the drink will be saved one after the other while the drink is being made.

The programmed combination of ingredients and portion sizes will now be dispensed every time that particular drink is selected.

## Expert mode

---

In Expert mode you can allocate a type of bean for one time and change the portion size while the drink is being made. The setting will **not** be saved and will only apply for the current drink.

### Switching Expert mode on and off

Expert mode is located in the pull-down menu at the top edge of the screen.

- Touch the top edge of the screen in the middle and drag down with your finger to open Expert mode.

The schematic representation of the bean containers will be displayed.

- Touch Expert mode.

Expert mode is active when Expert mode is highlighted in orange.

- To exit the pull-down menu, slide the menu window up or touch the screen outside of the pull-down menu.

### Expert mode: allocating bean containers

- Touch the top edge of the screen and open the Expert mode pull-down menu.
- Now select the bean container whose beans are to be used for the current drink.
- Slide the menu window back up to close it.
- Switch to the drinks menu if necessary.
- Now start making the drink.

### Expert mode: changing the portion size

The drinks menu is displayed.

If you select DoubleShot ☉ or 2 portions ☐, Expert mode cannot be used to change the portion size.

- Select a drink.

Dispensing will start. You can adjust the portion size while it is being dispensed, e.g. individually change the amount of hot milk, milk froth and espresso for Latte macchiato.

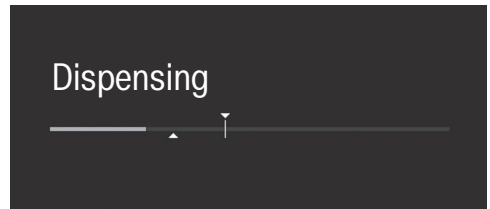

- Touch the bar and adjust the indicator (small triangle) as you wish.

The grinder setting determines the contact time between the ground coffee and the water, known as the extraction time. Only when the ideal grinder setting is selected, can the machine dispense a perfect cup of coffee with a fine, hazelnut-brown crema.

### Recognising the correct grinder setting

There are various ways to tell whether the coffee grinder is set correctly.

The grinder setting is **too coarse** if the coffee or espresso is watery and tastes acidic. The crema is very pale.

The grinder setting is **too fine** if the coffee or espresso tastes too bitter and the crema is dark brown.

### Adjusting the grinder setting

If the grinder setting is adjusted by more than one setting at a time, the grinder can be damaged.

Only adjust the grinder one setting at a time.

Dispense a drink after each adjustment in order to grind a portion of coffee beans. Adjust the grinder setting one setting at a time again.

The slide control for the grinder setting is located at the top left behind the water container.

- Open the appliance door.
- Remove the water container.

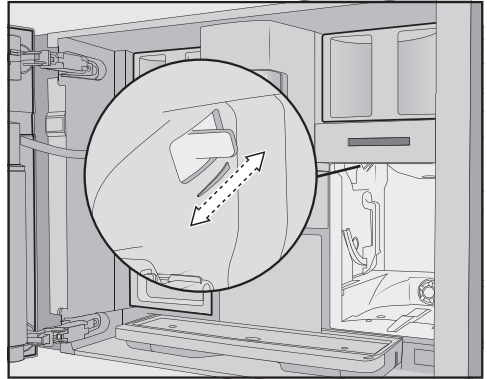

- Push the slide control **one setting** to the front (for finer grinding) or to the back (for coarser grinding).

The grinder setting you select will be used for all coffee drinks and all types of beans.

- Push the water container back into the machine.
- Close the appliance door.
- Make one cup of coffee.

Then you can adjust the grinder setting again.

The grinder wears out a little naturally over time with use. Set the grinder to a finer setting if necessary.

# Parameters

---

## Type of beans

You can display which type of bean is being used at the moment for this coffee drink or even the allocation of the bean container for the selected drink.

## Amount of coffee

The coffee machine can grind and brew 7.5–12.5 g of coffee beans per cup. The greater the quantity, the stronger the coffee.

The quantity of coffee is **too low** if the espresso or coffee lacks body.

To brew more ground coffee, increase the amount of coffee.

The quantity of coffee is **too high** if the espresso or coffee tastes bitter.

To brew less ground coffee, decrease the amount of coffee.

## Pre-brewing ground coffee

When the pre-brewing function is switched on, the ground coffee is first moistened with a little hot water. The ground coffee swells a little. The remaining amount of water is then pressed through the moistened coffee grounds shortly after. If your coffee tastes too bland and you want to add some spice and richness, try the “Pre-brewing” function. Depending on the type of coffee used, pre-brewing can intensify the taste.

You can set a short or long duration for pre-brewing or turn the “Pre-brewing” function off completely.

**Useful tip:** We particularly recommend using the “Pre-brewing” function to make coffee.

## Brewing temperature for coffee drinks

The brewing temperature must be adapted to the beans you are using and how they are roasted. It also varies depending on whether you are making espresso or coffee.

Some bean types are sensitive to high brewing temperatures, resulting in an impaired taste. If your coffee tastes bitter, the brewing temperature you have selected might be too high.

Espresso is usually brewed at higher temperatures.

## Dispensing temperature for tea drinks, warm water and hot water

You can adjust the dispensing temperatures used for the individual tea drinks and for warm and hot water by customising the brewing temperature.

Even a change in temperature of approx. 2 °C makes a difference.

## Portion size

You can adjust the amount of water for all coffee drinks, hot water and types of tea.

The strength of the coffee is determined by the ratio between the amount of ground coffee and water. If the coffee is brewed with more water but with the same amount of coffee, the coffee will taste milder and thinner. If you reduce the amount of water, you will get a stronger and more powerful coffee.

If you significantly increase or decrease the portion size and therefore the amount of water for a coffee, you should also adjust the amount of coffee accordingly.



For coffee drinks with milk, you can also set the amount of milk or milk froth to suit your personal taste. Additionally, you can set the portion sizes for hot milk and milk froth alone.

The changed portion size is always saved in the current profile. The name of the current profile is shown in the top left of the display.

If the water container becomes empty during the preparation of a drink, the programming of the portion size will be cancelled. The new portion size will **not** be saved.

## Displaying and changing parameters

You can individually adjust the following parameters for each drink:

- Bean type
- Amount of coffee
- Brewing temperature
- Pre-brewing

You can adjust the brewing temperature for tea drinks, warm water and hot water.

The drinks menu is displayed.

- Touch and hold the required drink name until the context menu for this drink appears.
- Select Parameters.

The Parameters menu is shown in the display.

- Select the required parameters.

The current setting will be displayed.

- Change the setting as required.

## Resetting drink settings

You can reset portion sizes and parameters individually or for all drinks back to their factory default settings.

The drinks menu is displayed.

- Touch and hold the required drink entry until the context menu opens.
- Select Reset and confirm with Yes

The portion size and parameters will be reset to the factory default settings. The allocation of the type of bean remains saved.

# User profiles

---

## User profiles

In addition to the Miele drinks menu (Miele profile), you can create individual profiles to cater for different tastes and preferences.

Within the profile, you can adjust the portion sizes and parameters individually for all drinks.

## Creating a profile

The drinks menu is displayed.

- Touch User profiles.

The User profiles menu opens.

- Touch Create profile.

The editor will open in the display.

- Enter the name you want.
- Touch Save.

The profile is created. You can now create drinks (see "Profiles: creating and editing drinks").

## Editing a profile

You can rename, delete or move profiles you have created yourself.

The drinks menu is displayed.

- Touch User profiles.

The User profiles menu opens.

- Touch and hold the required profile name until the context menu appears.
- Edit the entry as required.

## Setting change of profile

The drinks menu is displayed.

- Touch User profiles.

The User profiles menu opens.

- Touch and hold the required profile name until the context menu appears.
- Select the desired option.

You can select from the following options:

- **Manual:** The selected profile remains active until you select another profile.
- **After each use:** The Miele profile is displayed after every drink.

## Profiles: creating and editing drinks

---

You can save frequently made drinks in a profile with your own individual settings (see “User Profiles”).

You can also change the names of your drinks and delete any unwanted drinks from your profile. You can save a maximum of 9 drinks in a profile.

### Creating a drink

You can create new drinks based on existing drinks.

The drinks menu is displayed.

- Touch *User profiles*.

The *User profiles* menu opens.

- Select the profile you want.

The name of the profile is shown in the top left of the display.

- Touch *Create drink*.

- Now select a drink.

- Change the portion size or drink parameters for this drink as required.

Drink preparation will begin and you can save the portions of each component as desired.

- Enter a name for the new drink and touch *Save*.

The new drink will appear in the current profile.

### Renaming, moving or deleting drinks

If you have already created drinks, you can edit these drinks in the context menu.

The desired profile with the newly created drinks will appear in the display.

- Touch and hold the drink name until the context menu appears.
- Edit the entry as required.

# MyMiele

---

You can display drinks you make frequently, drinks from profiles and maintenance programmes in the MyMiele screen.

**Useful tip:** You can also set menu options that you have entered into MyMiele to appear on the start screen (see “Settings – Start screen”).

The main menu is displayed.

- Touch MyMiele.

You can now configure MyMiele.

## MyMiele: Adding an entry

- Touch Add entry.

You can now add entries from the following menus:

- Drinks
- User profiles
- Maintenance

- Select an entry.
- Confirm the message with *OK*.

A box will appear next to the selected entry together with the menu it comes from.

## MyMiele: Deleting or moving an entry

If you have already created entries, these can be moved or deleted in the context menu in the MyMiele screen.

- Touch and hold the entry until the context menu appears.
- Move or delete the entry as required.

With MobileStart  you can, for example, start making a drink via the Miele App.

You can only use MobileStart if Miele@home is set up for your coffee machine.

 Danger of burning and scalding on the dispensing spouts. If liquids or steam are dispensed while the machine is unsupervised, persons may burn themselves if they place body parts under the central spout or touch hot components. Ensure that no one, especially children, can be harmed if the machine is operated without supervision.

Automatic cleaning and automatic descaling cannot be carried out if MobileStart  is activated. The pipework is not pre-warmed when the machine is switched on either so that the cup under the central spout is not filled with rinse water.

Milk is not cooled in the milk flask. If you want to start making a drink with milk using the App, make sure that the milk is sufficiently cold (< 10 °C).

If the coffee machine is being operated manually, it cannot be operated via the App. Operation on the appliance takes precedence.

To start making drinks remotely, MobileStart  must be activated. Make sure that the coffee machine is ready to use, for example check that the water container is sufficiently filled. Place a sufficiently large, empty cup or glass under the central spout.

MobileStart will be deactivated after 24 hours.

If you are making a drink with MobileStart , you will be notified of drink dispensing with acoustic and optical signals. These signals cannot be changed or switched off.

## Switching MobileStart on and off

If you want to use MobileStart , the Remote control option must be switched on.

The drinks menu is displayed.

■ Touch the  sensor.

The  sensor lights up. You can now start making a drink via the App. Follow the prompts for doing this.

# Settings

You can personalise your coffee machine by adapting the factory default settings to your requirements.

## Displaying and changing settings

The drinks menu is displayed.

- Touch the ↩ sensor.
- Select Settings.
- Select the option you want to change.
- Change the setting.

If necessary, confirm the selection with *OK*.

Some settings which can be found in the Settings menu are described in their separate sections in the operating instructions.

## Language

You can select a language and location variant for all display texts.

**Useful tip:** If you select the wrong language by mistake, you can find the "Language" option again via the  symbol.

## Time of day

### Display (time of day display)

Select how you want the time of day to appear in the display when the coffee machine is switched off:

- **On:** The time is always visible in the display.
- **Off:** The time is not displayed.
- **Night dimming:** To save energy, the time is displayed from 5:00 am to 11:00 pm only.

When the time of day display is switched on, the energy consumption of the coffee machine increases.

## Clock type

You can choose to show the time in an **analogue** (clock face) or **digital** (hours:minutes plus date) form when the coffee machine is switched off.

## Clock format

- 24-hour display (24 h)
- 12-hour display (12 h)

## Setting

Set the hours and then the minutes.

**Useful tip:** By touching the time of day in the top right of the display, you can set the time without opening the Settings menu.

If the coffee machine has been connected to a Wi-Fi network and is signed into the Miele App, the time will be synchronised based on the location setting in the Miele App.

## Date

Set the date.

The date only appears in the Time | Clock type | Digital setting.

## Start screen

You can choose which menu appears when the coffee machine is switched on. For example, you can display a personalised menu with MyMiele (see "MyMiele").

The modified start screen will be displayed after switching on again.

The drinks menu is set as the start screen at the factory.

## Timer

### Appliance timer

The coffee machine has three timers:

- Switch on at
- Switch off at
- Switch off after

You can allocate individual timer functions to different days of the week. You can set various timer periods for the weekend (Sat. and Sun.) and/or Monday to Friday (Monday-Friday). Alternatively, you can select **Daily** if you want to activate a timer for every day.

**Useful tip:** If the timer cannot be set and the screen is greyed out, touch **On** to activate the timer setting.

To save the timer settings and activate the timer, select **Accept all**.

Select **Switch all off** to deactivate the timer function.

With **Delete** you can deactivate timers individually. -- -- then appears in the display.

### Switch on at (On at)

The coffee machine switches on at a particular time, e.g. in the morning for breakfast.

The coffee machine will **not** switch on at the required time if you have activated the system lock. The timer settings are deactivated.

If the coffee machine has switched itself on automatically **three times** at the specified time and no drinks have been dispensed, the machine will not switch itself on again automatically. This prevents the coffee machine from switching itself on unnecessarily, for example, whilst you are away on holiday.

The programmed times will, however, remain in memory and will be reactivated after manually switching the machine on again.

If you have switched on the time display for the switched off appliance (**Display | On or Night dimming**) and the digital clock type has been selected (**Clock type | Digital**) the  symbol and the desired switch-on time will appear in the display up to 23:59 hours ahead of time.

### Switch off at (Off at)

The coffee machine switches off at a particular time.

### Switch off after (Switch off after)

The coffee machine switches off after a particular length of time if no sensors have been touched.

Under the default settings the coffee machine switches off after 20 minutes.

You can change this preset to a time of between 20 minutes and 9 hours.

Extending the **Switch off after time** increases the energy consumption of the coffee machine.

If you deactivate the timer functions with **Switch all off**, the coffee machine will switch off after the most recent time selected for **Switch off after**. You cannot deactivate this timer.

### Maintenance timer

Use the Maintenance timer to select any start time you like for the automatic maintenance programmes (see “Automatic cleaning and descaling - Maintenance timer” section).

# Settings

---

## TeaTimer

You can use the TeaTimer function to start a minute minder when making tea. A specific brewing time is preset for the selected type of tea. You can change the preset brewing time (max. 14:59 minutes).

The machine has two TeaTimers that can be started independently from one another.

You can select from the following options:

- **Automatic:** The TeaTimer starts automatically when tea dispensing has finished.
- **Manual:** When tea dispensing has finished, you have the option of starting the TeaTimer.

The TeaTimers are displayed in the top right of the display with their relevant brewing time.

While the brewing time is counting down, you can continue to use the coffee machine as normal. An audible tone will sound and the ⌚ symbol will flash after the brewing time has elapsed.

## Volume

You can set the volume of buzzer and keypad tones using a segment bar.

## Display

### Display brightness

The display brightness is set using a segment bar.

### Colour scheme

Select whether the display is to be shown with a bright or dark colour scheme.

## QuickTouch

Set whether the ☼ sensor control and the proximity sensor react when the coffee machine is switched off and the time of day appears in the display (Time | Display | On or Night dimming).

## Lighting

Lighting intensity is set using the segment bar.

You can use the ☼ sensor to switch the lighting on or off at any time as long as the coffee machine is switched on.

If the coffee machine is switched off, you can still switch the lighting on or off whenever you like if you select the following settings:

- Time | Display | On or Night dimming (time is not displayed)
- Display | QuickTouch | On

The brighter the lighting is set and the longer it is switched on, the higher the energy consumption of the coffee machine.

## Info (display information)

In the Info menu option, you can display the number of drinks and the fill levels of the cartridges (provided they are fitted).

## Mains water

The appliance is intended to be operated with a mains water connection. If mains water connection has been switched on, the water container is filled automatically via the mains water supply. If it is switched off, the water container must be filled manually.



## Altitude

If the coffee machine is installed at high altitudes, the lower air pressure will cause the water to boil at a comparatively lower temperature. You can set the local altitude of the machine to ensure that the correct temperatures are achieved.

## Performance mode

You can select the most suitable Performance mode for your type of use:

- Eco mode
- Barista mode
- Latte mode

There is also a mode for occasional, intensive use of the coffee machine: Party mode.

## Eco mode

In Eco mode, the coffee machine consumes the least amount of energy. The system only heats up once drink preparation has started.

Eco mode is set as standard. Selecting a Performance mode other than Eco mode increases the energy consumption of the coffee machine.

## Barista mode

This Performance mode is optimised for perfect coffee enjoyment. Coffee drinks can be prepared without any delay as the coffee machine remains heated to the brewing temperature.

Barista mode consumes more energy than Eco mode.

## Latte mode

This Performance mode is optimised for preparing drinks containing milk. In Latte mode, milk-based drinks can be prepared much faster.

Latte mode consumes more energy than Eco mode and Barista mode.

## Party mode

This Performance mode is designed for **infrequent**, intensive use of the coffee machine, e.g. for family parties.

Empty the drip tray and fill the water container before switching off the coffee machine to ensure scheduled maintenance programmes can be carried out.

After intensive use, clean the coffee machine, and particularly the milk pipework, thoroughly. If necessary, descale the coffee machine manually and degrease the brew unit.

Please note the following information about Party mode:

- The pipework is rinsed much less frequently or not at all. The milk pipework is not rinsed until around 1 hour after the last drink with milk was dispensed.
- Any messages on the maintenance status, or maintenance prompts, are suppressed and delayed until the next time the machine is switched on.
- Cup lighting on the central spout is switched on permanently at the maximum brightness level for as long as the coffee machine is switched on.
- The Off at and Switch off after timer are deactivated.

# Settings

- The coffee machine switches off 6 hours after the last sensor has been touched. The next time the appliance is switched back on, Party mode is switched off and the most recently set Performance mode is switched back on.

Party mode consumes more energy than other Performance modes.

## Water hardness

Programme the coffee machine to the water hardness level of your area so that it functions correctly and does not get damaged.

Contact your local water supplier to find out your local water hardness range if necessary.

If you are using bottled drinking water, e.g. mineral water, select settings according to the calcium content. The calcium content is given on the label of the bottle in mg/l Ca<sup>2+</sup> or ppm (mg Ca<sup>2+</sup>/l).

Do not use carbonated water.

The water hardness is preset at the factory to 21° dH (3.8 mmol/l).

| Water hardness |        | Calcium content<br>mg/l Ca <sup>2+</sup> or<br>ppm (mg Ca <sup>2+</sup> /l) | Setting |
|----------------|--------|---|---------|
| °dH            | mmol/l |   |         |
| 1              | 0.2    | 7   | 1       |
| 2              | 0.4    | 14  | 2       |
| 3              | 0.5    | 21  | 3       |
| 4              | 0.7    | 29  | 4       |
| 5              | 0.9    | 36  | 5       |
| 6              | 1.1    | 43  | 6       |
| 7              | 1.3    | 50  | 7       |
| 8              | 1.4    | 57  | 8       |

| Water hardness |           | Calcium content<br>mg/l Ca <sup>2+</sup> or<br>ppm (mg Ca <sup>2+</sup> /l) | Setting |
|----------------|-----------|---|---------|
| °dH            | mmol/l    |   |         |
| 9              | 1.6       | 64  | 9       |
| 10             | 1.8       | 71  | 10      |
| 11             | 2.0       | 79  | 11      |
| 12             | 2.1       | 86  | 12      |
| 13             | 2.3       | 93  | 13      |
| 14             | 2.5       | 100   | 14      |
| 15             | 2.7       | 107   | 15      |
| 16             | 2.9       | 114   | 16      |
| 17             | 3.0       | 121   | 17      |
| 18             | 3.2       | 129   | 18      |
| 19             | 3.4       | 136   | 19      |
| 20             | 3.6       | 143   | 20      |
| 21             | 3.8       | 150   | 21      |
| 22             | 3.9       | 157   | 22      |
| 23             | 4.1       | 164   | 23      |
| 24             | 4.3       | 171   | 24      |
| 25             | 4.5       | 179   | 25      |
| 26             | 4.6       | 186   | 26      |
| 27             | 4.8       | 193   | 27      |
| 28             | 5.0       | 200   | 28      |
| 29             | 5.2       | 207   | 29      |
| 30             | 5.4       | 214   | 30      |
| 31             | 5.5       | 221   | 31      |
| 32             | 5.7       | 229   | 32      |
| 33             | 5.9       | 236   | 33      |
| 34             | 6.1       | 243   | 34      |
| 35             | 6.3       | 250   | 35      |
| 36             | 6.4       | 257   | 36      |
| 37-45          | 6.6-8.0   | 258-321   | 37-45   |
| 46-60          | 8.2-10.7  | 322-429   | 46-60   |
| 61-70          | 10.9-12.5 | 430-500   | 61-70   |

**Useful tip:** If your water hardness is >21 °dH (3.8 mmol/l), we recommend instead to use bottled drinking water (< 150 mg/l Ca<sup>2+</sup>). This will mean your coffee machine will need to be descaled less often and there will be less impact on the environment because less descaling agent will be used.

## Proximity sensor

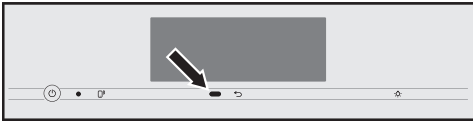

The proximity sensor detects when your hand or body comes close to the touch display. You can activate the following functions separately:

- **Switch the light on:** You can decide whether the light switches on when the coffee machine is switched on or off.
- **Acknowledge buzzer:** Buzzer tones are suppressed, e.g. with the Fill and replace the water container message.
- **Switch the appliance on:** The start screen is displayed.

The proximity sensor is deactivated as standard.

If you want the proximity sensor to react even if the coffee machine is switched off, switch on QuickTouch as well (Display | QuickTouch | On).

If the system lock is activated, the functions of the proximity sensor are deactivated.

When the system lock is activated, the settings for the On at timer and the proximity sensor are deactivated. The coffee system will **not** switch on at the time set and/or does not react on approach.

## Overriding the system lock

- Touch and hold the display for 6 seconds.

The system lock is activated the next time the machine is switched off.

## Miele@home

The following points may appear under Miele@home:

- **Set up:** This option only appears if the coffee machine has not previously been connected to a Wi-Fi network or if the network configuration has been reset.
- **Deactivate\*/Activate\*:** The settings for the Wi-Fi network are retained, but the network is switched on or off.
- **Connection status\*:** Information about the Wi-Fi connection is displayed. The symbols indicate the strength of the connection.
- **Set up again\*:** The settings for the current Wi-Fi network will be reset. The Wi-Fi connection will be set up again.
- **Reset\*:** The settings for the current Wi-Fi network will be reset.

## System lock

You can lock the coffee machine to prevent it being used without your knowledge, for example by children.

# Settings

---

The network configuration should be reset whenever the coffee machine is being disposed of or sold, or if a used coffee machine is being put into operation. This is the only way to ensure that all personal data has been removed and, in the case of the latter, the previous owner will no longer be able to access the coffee machine.

\* This option appears if Miele@home has been set up and the coffee machine has been connected to your Wi-fi network.

## Remote control

The Remote control menu option appears if Miele@home has been set up and the coffee machine has been connected to a Wi-Fi network.

You can change the coffee machine settings, for example, in the Miele App when remote control is switched on. To start making a drink via the App, MobileStart must be additionally activated.

Remote control is switched on as standard.

## SuperVision

SuperVision appears when the coffee machine is connected to a Wi-Fi network.

SuperVision can be used to monitor other appliances within the Miele@home system.

## SuperVision display

If SuperVision is switched on (SuperVision | On), the  symbol appears in the display.

## Standby display

SuperVision is also available in standby if the time display is switched on (Settings | Time | Display | On or Night dimming).

## Appliance list

All household appliances signed on to the Miele@home system are listed.

You can switch SuperVision on or off for the signed on appliances. If you switch off SuperVision for one of your appliances, any faults will still be displayed for this appliance.

Buzzer tones for the listed appliances can also be switched on or off.

## RemoteUpdate

The RemoteUpdate function is used for updating the software in your coffee machine. If an update is available for your coffee machine, this will be downloaded by the machine automatically. Updates will not be installed automatically. They must be initiated manually.

If you do not install an update, you can continue to use your coffee machine in the usual way. However, Miele recommends installing updates.

The RemoteUpdate menu option is only displayed and can only be selected if the requirements for using Miele@home have been met.

RemoteUpdate is switched on as standard. Available updates will be downloaded automatically but will only be installed if you initiate the installation manually.

Deactivate RemoteUpdate if you do not want any updates to be downloaded automatically.

## Running a RemoteUpdate

Information about the content and scope of an update is provided in the Miele App.

A message will appear in your coffee machine display if an update is ready for installation.

You can install the update immediately or postpone this until later. You will be reminded about the update the next time you switch the coffee machine on.

Deactivate RemoteUpdate if you do not want to install the update.

The update may take several minutes.

Keep in mind the following with respect to RemoteUpdates:

- You will only receive a message when a RemoteUpdate is available.
- Once a RemoteUpdate has been installed, it cannot be undone.
- Do not switch off the coffee machine while an update is being downloaded or installed. Otherwise, the update will be aborted and will not be installed.
- Some software updates can only be carried out by Miele Customer Service.

## Software version

The “Software version” menu option is intended for Miele service technicians. You do not require this information for your own use.

## Legal information

You will find the Open Source Licences used under this menu option.

## Showroom programme (Demo mode)

Do not activate this setting for domestic use.

The Showroom programme | Demo mode function enables the coffee machine to be demonstrated in stores or showrooms. In this mode, the machine lights up but drinks cannot be prepared and no maintenance programmes can be carried out.

You can activate Demo mode without commissioning the appliance. Switch the coffee machine on and off again. Then immediately touch and hold the ↵ sensor for 5 seconds. Demo mode is active.

## Factory default settings

You can reset the settings back to the ones which were set when the coffee machine was delivered - the factory default settings.

MyMiele can be reset separately.

The following will **not** be reset:

- The number of drinks and the appliance status (No. of uses until appliance needs descaling, ... brew unit needs degreasing)
- Language
- Time and date
- Profiles and their associated drinks (the allocation of bean types to drinks is reset)
- Miele@home

The Maintenance timer is reset to 2:00.

## Cleaning and care

 Risk to health due to inadequate cleaning.

Heat and moisture inside the coffee machine can cause coffee residues to become mouldy and/or milk residues to go off and pose a risk to health.

Carefully clean the coffee machine regularly.

### Cleaning intervals - Quick guide

| Recommended frequency                                | What do I have to clean/maintain?                                |
|--|--|
| <b>Every day</b><br>(at the end of the day)          | Milk flask and lid   |
|  | Milk valve   |
|  | Water container  |
|  | Drip tray cover  |
|  | Drip tray and waste container                                    |
| <b>Once a week</b><br>(more often if heavily soiled) | Central spout  |
|  | Cup rim sensor   |
|  | Interior   |
|  | Brew unit  |
|  | Drip catcher   |
|  | Appliance front  |
| <b>Once a month</b>                                  | Bean container   |
|  | Remove and clean the milk valve                                  |
| <b>As required / When prompted by display</b>        | Milk pipework (using the Miele Cleaning agent for milk pipework) |
|  | Degrease the brew unit (using the cleaning tablets)              |
|  | Descale the appliance  |

### Cleaning by hand or in the dishwasher

The brew unit is **not** dishwasher-safe. Clean the brew unit by hand only under warm running water. **Do not use washing-up liquid or any other cleaning agent.**

The following must be cleaned **by hand only**:

- Central spout stainless steel cover
- Brew unit
- Coffee bean container and lid

 Risk of damage as a result of excessively high dishwasher temperatures.

Components may be rendered unusable (e.g. deformed) if washed in a dishwasher at a temperature of more than 55 °C.

For dishwasher-safe parts, the maximum temperature of the dishwashing programme selected must not exceed 55 °C.

Contact with natural dyes such as those found in carrots, tomatoes and ketchup may discolour the plastic parts in the dishwasher. This discolouration does not affect the stability of the parts.

The following components are **dishwasher safe**:

- Drip tray with lid and waste container
- Drip tray cover
- Central spout (without stainless steel cover)
- Milk flask with lid
- Cup sensor

- Drip catcher
- Maintenance container
- Water container

 Danger of burning and scalding on hot components or by hot liquids. Components can become very hot during operation. Touching hot components can cause burning. The liquids and steam dispensed are very hot and can cause scalding. Keep well away from the area underneath the spouts when hot liquids and steam are being dispensed.

Always allow the coffee machine to cool down before cleaning it.

Please be aware that water in the drip tray can also be very hot.

 Risk of damage due to moisture ingress.

The steam from a steam cleaner could reach electrical components and cause a short circuit.

Do not use a steam cleaner to clean the coffee machine.

It is important to clean the machine regularly, as the used coffee grounds will soon go mouldy. Milk residues can go off and can block the milk pipework.

# Cleaning and care

## Unsuitable cleaning agents

Contact with unsuitable cleaning agents can alter or discolour all surfaces. All surfaces of this appliance are susceptible to scratching. Scratches on glass surfaces could cause a breakage in certain circumstances.

Remove any residual cleaning agent immediately. To protect the machine and surrounding surfaces from damage, make sure you remove any spillages or splashes of descaling agent immediately.

To avoid damaging the surfaces of your appliance, do not use:

- cleaning agents containing soda, alkalines, ammonia, acids or chlorides
- solvent-based cleaning agents
- cleaning agents containing descaling agents (unsuitable for cleaning the appliance front)
- stainless steel cleaning agents
- dishwasher cleaners (unsuitable for cleaning the appliance front)
- glass cleaning agents
- cleaning agents for ceramic cooktops
- oven cleaner
- abrasive cleaning agents, e.g. powder cleaners and cream cleaners
- hard, abrasive brushes or sponges, e.g. pot scourers, brushes or sponges which have been previously used with abrasive cleaning agents
- dirt erasers
- sharp metal scrapers
- steel wool or stainless steel wire scourers

## Cleaning the drip tray and waste container

 Danger of burning and scalding on hot components or by hot liquids. Components can become very hot during operation. Touching hot components can cause burning. The liquids and steam dispensed are very hot and can cause scalding.

If the pipework has just been rinsed, wait a while before removing the drip tray as the water used for rinsing will still run out of the coffee spouts.

Please be aware that water in the drip tray can also be very hot.

Do not touch hot components.

To avoid unpleasant smells and mildew, clean the drip tray and waste container **every day**.

A prompt will appear in the display when the drip tray and/or the waste container is full and needs to be emptied. Empty the drip tray **and** the waste container. The lid of the drip tray does not need to be removed for emptying.

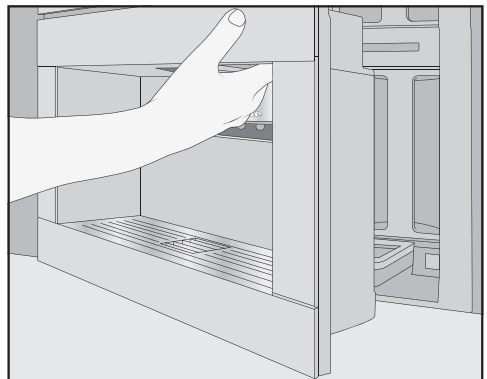

- Open the appliance door.



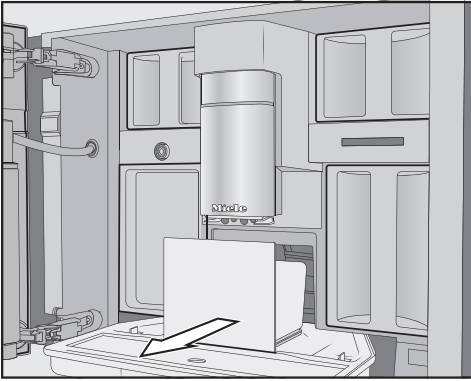

- Remove the drip tray with the waste container from the appliance.
- Remove the waste container from the drip tray and empty the waste container.

Apart from coffee grounds, there may also be some water in the waste container.

## Dismantling the drip tray

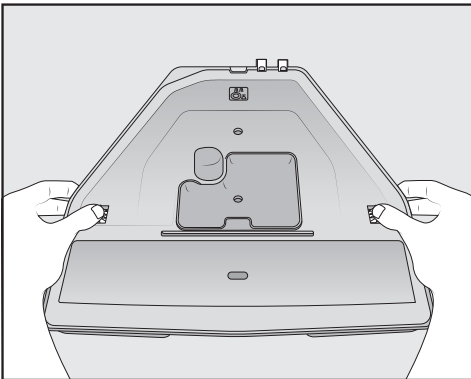

The orange latches are not removable.

- Remove the lid from the drip tray: push the orange latches on either side outwards and undo the lid.
- Take the lid off.

- Clean the drip tray, the lid and the waste container by hand using warm water and a mild solution of washing-up liquid.

- Dry all parts afterwards.

**Useful tip:** To clean the drip tray, the lid and the waste container particularly thoroughly, clean them occasionally in the dishwasher. If the drip tray is very dirty, clean it with a brush prior to placing it in the dishwasher.

- Clean the interior of the coffee machine underneath the drip tray.

## Cleaning the drip tray contacts

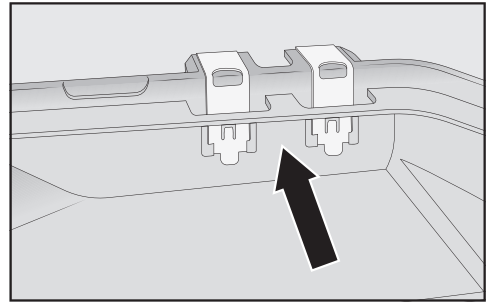

- Clean the contacts (metal discs) and the space between them carefully, e.g. with a soft brush.
- Dry all parts thoroughly.

The contacts will not be able to detect that the drip tray is full if they are damp or dirty. Check the contacts and the area around them once a week.

# Cleaning and care

## Assembling the drip tray

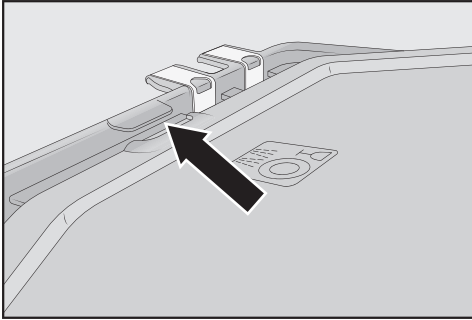

- Refit the lid of the drip tray: push the lid in under the lip next to the contacts and press down on the lid until the latches click into place.

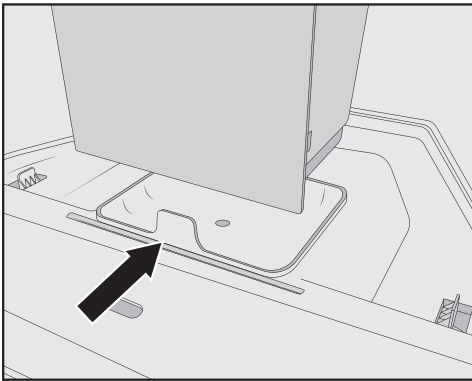

- Place the waste container on top of the lid.
- Push the drip tray, together with the waste container, back into the coffee machine.
- Close the appliance door.

## Cleaning the drip tray cover

Clean the drip tray cover every day.

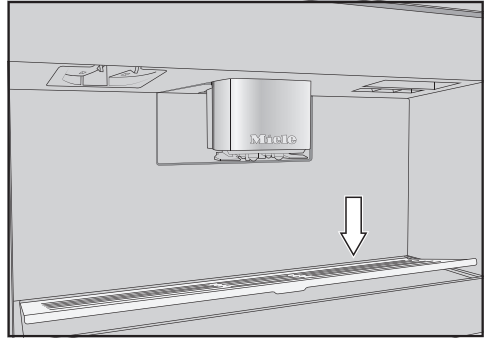

- Remove the drip tray cover: to do this, push down on the rear edge of the cover so that the front lifts up and can be easily removed.
- Clean the drip tray cover by hand using warm water, a little washing up liquid, and a soft cloth.
- Dry the drip tray cover.
- Refit the drip tray cover.

**Useful tip:** To clean the drip tray cover particularly thoroughly, clean it occasionally in the dishwasher.

## Cleaning the water container

Clean the water container by hand every day.

- Open the appliance door.
- Remove the water container.
- Clean the water container daily by hand with warm water and a little washing-up liquid.
- Clean the water container and rinse it with clean water to remove any dishwashing liquid residues.
- Dry the outside of the water container.

**Useful tip:** To clean the water container particularly thoroughly, clean it occasionally in the dishwasher.

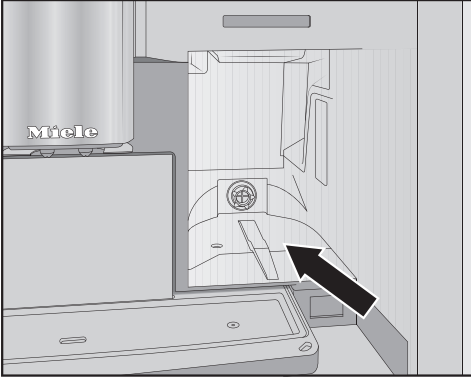

- Clean and dry the surface that the water container sits on.
- Push the water container all the way into the coffee machine.
- Close the appliance door.

## Cleaning the central spout

Clean the central spout stainless steel cover by hand only using warm water and a little washing-up liquid.

Clean all parts of the central spout at least once a week.

## Removing the central spout

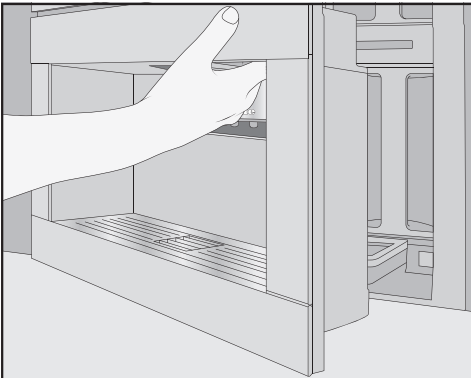

- Open the appliance door.
- Carefully pull the stainless steel cover off the central spout.

- Clean the central spout's stainless steel cover.

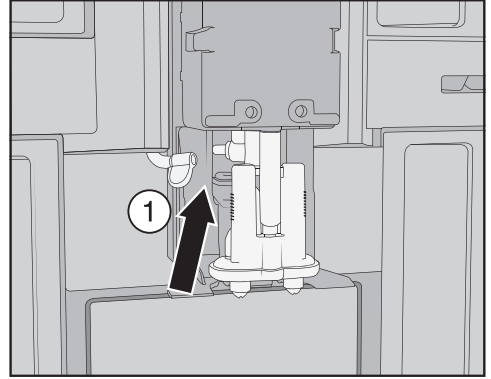

- Release the milk pipework from the dispensing unit: to do this, pull the lug ① to the left.

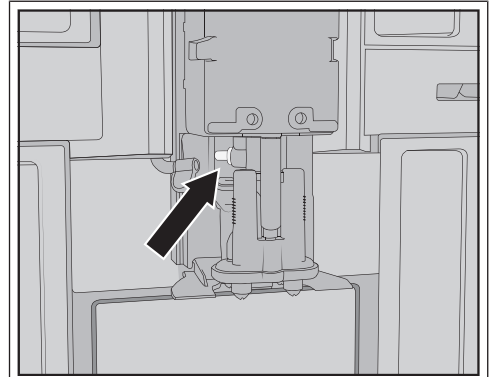

Do **not** remove the milk pipework connecting piece.  
Clean the connecting piece, if necessary, with the cleaning brush.

## Cleaning and care

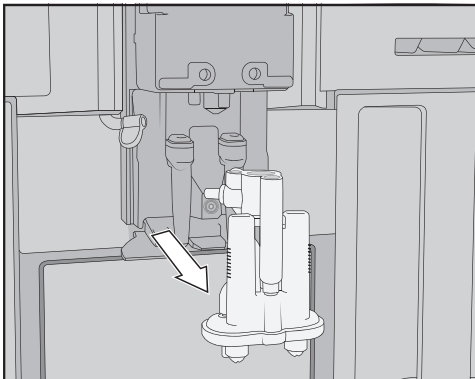

- Hold the dispensing unit on either side and pull down to remove it.

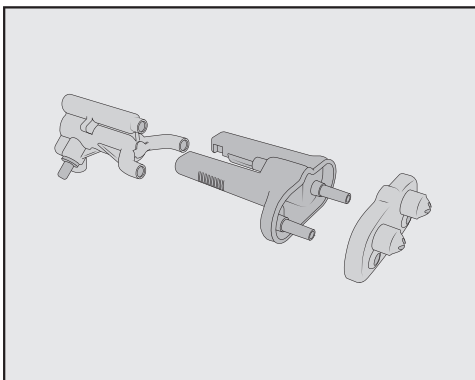

- Dismantle the dispensing unit into three pieces: disconnect the Y-shaped piece, the dispensing spouts and the holder from one another.

### Cleaning the central spout

Clean the central spout stainless steel cover by hand only using warm water and a little washing-up liquid.

- Clean all parts thoroughly by hand.

**Useful tip:** To clean the components of the central spout particularly thoroughly, clean them occasionally in the dishwasher (Exception: stainless steel cover). This will remove coffee deposits and milk residues effectively.

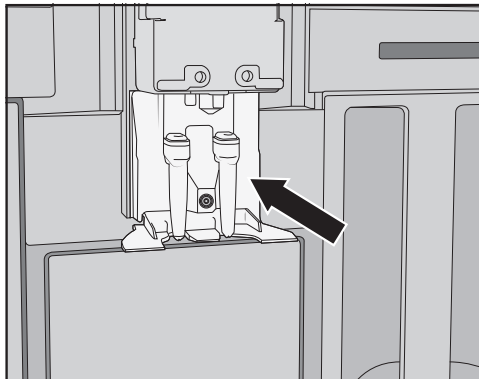

- Clean the area surrounding the central spout with a damp cloth.

### Fitting the central spout

The dispensing unit is easier to reassemble if the individual parts are dampened with water beforehand.

Make sure that all parts are tightly connected to one another.

- Reassemble the dispensing unit.
- Press firmly to connect the dispensing spouts correctly to the holder.

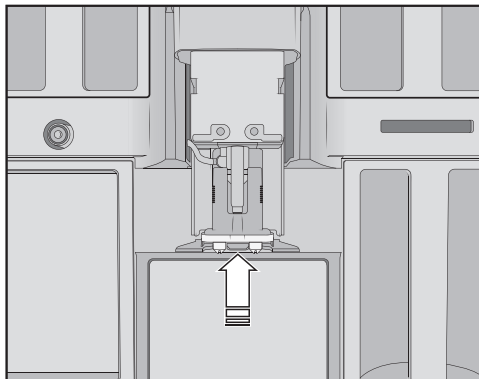

- Insert the dispensing unit in the coffee machine.
- Connect the milk pipework.

- Refit the stainless steel cover.
- Close the appliance door.

Fit cover to central spout appears in the display.

- Confirm with *OK*.

## Cleaning the cup rim sensor

Clean the cup rim sensor at least once a week and more often if heavily soiled.

The cup rim sensor is located underneath the central spout.

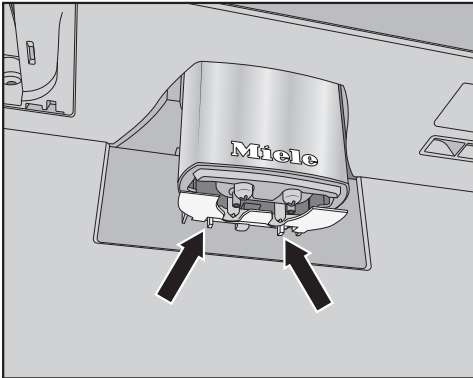

- Push the two locking catches together (see arrows).

The cup rim sensor will be released.

- Clean the cup rim sensor by hand with warm water and a little washing-up liquid.

**Useful tip:** To clean the cup rim sensor particularly thoroughly, clean it occasionally in the dishwasher.

- Push the cup rim sensor from underneath into the holder on the central spout to refit it.

## Cleaning the milk flask with lid

The milk flask should be taken apart and cleaned every day after use.

Both the lid and the glass flask can be cleaned in the dishwasher, or by hand using warm water and a little washing-up liquid.

- Remove and empty the milk flask.

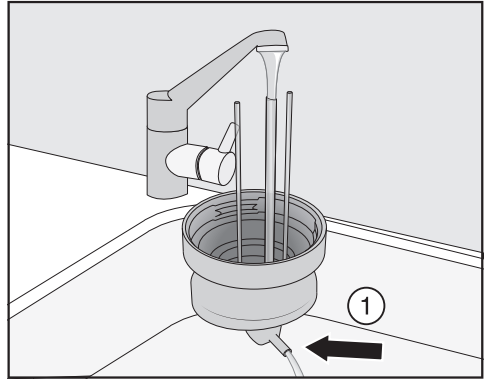

- Rinse the milk pipework in the lid under running water before placing the lid of the milk flask in the dishwasher.
- If water does not run out of the connecting piece ①, clean it with the cleaning brush.
- Clean the glass flask.
- Dry all parts and especially the threads on the lid and on the glass with a clean cloth.
- Reassemble the milk flask.

## Cleaning and care

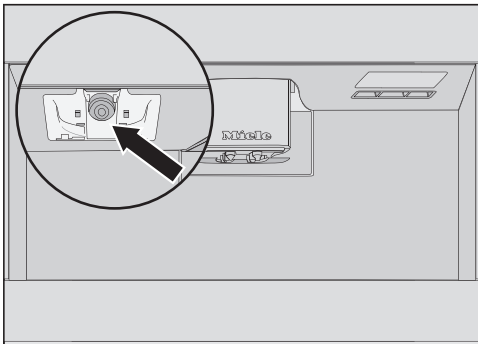

- Clean the milk flask holder on the coffee machine with a damp cloth.

### Cleaning the milk valve (daily)

The seal of the milk valve can be damaged by sharp-edged objects or similar.

Do not use sharp-edged objects, e.g. a knife, to clean the milk valve.

Clean the milk valve every day. Milk residues can accumulate on the stainless steel stem and dry on. These crusty deposits are difficult to remove. Therefore, it is important to carry out regular cleaning after preparing milk.

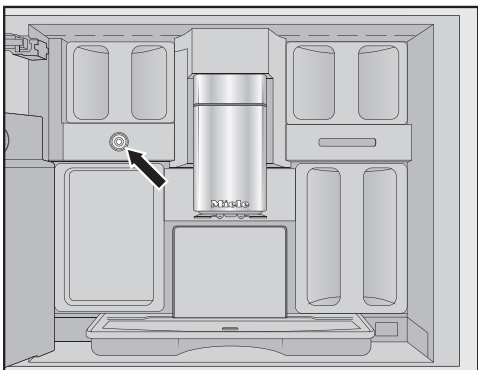

The milk valve is located under the bean container on the left-hand side.

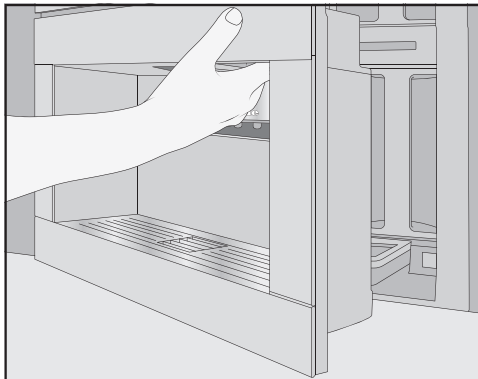

- Open the appliance door.
- Clean the milk valve with a damp sponge or microfibre cloth.
- Close the appliance door.

### Removing and cleaning the milk valve (once a month)

Remove the milk valve only when the coffee machine is switched off. Do **not** switch on the coffee machine while the milk valve is removed.

Remove and clean the milk valve at least once a month. When preparing milk, if hot milk is dispensed instead of milk froth, or the milk sputters when dispensed, the milk valve may be blocked. Clean the milk valve more often if necessary.

#### Removing the milk valve

Remove the milk valve only when the coffee machine is switched off. Do **not** switch on the coffee machine while the milk valve is removed.

- Switch the coffee machine off.

## Cleaning and care

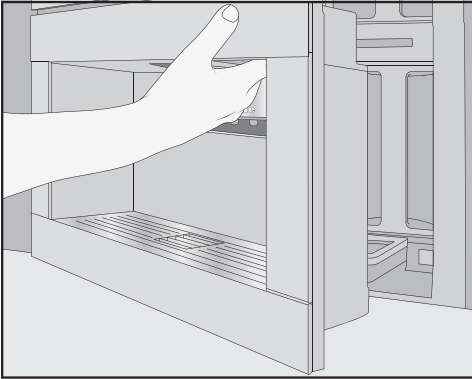

- Open the appliance door.
- Remove the bean container on the left and the maintenance container.
- Remove the central spout's stainless steel cover.

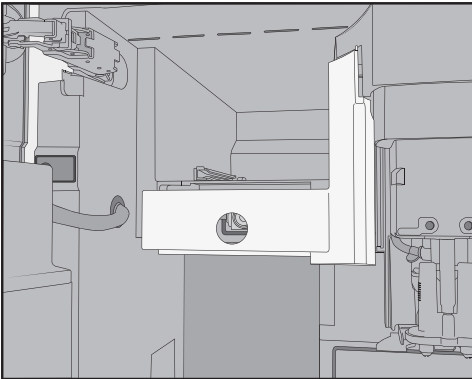

- Remove the milk valve cover: press on the recessed grip to unlock the cover. On the top right-hand side of the cover there is a pin which enables you to swing open the cover.

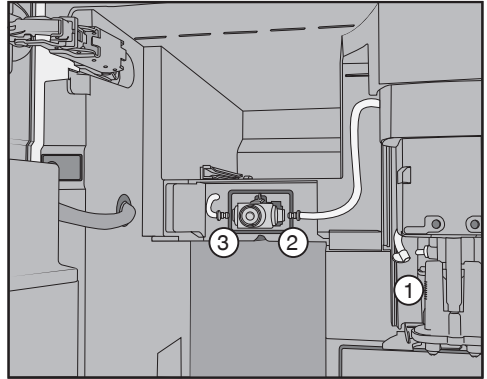

- Detach the milk pipework from the dispensing unit on the central spout ① and from the milk valve silicone seal (② and ③).
- Remove the milk pipework ① that connects the milk valve to the central spout.
- Disconnect the angular moulded hose from the round hose.
- Rinse the hoses thoroughly under running water.

Do **not** remove the connecting pieces from the hoses.

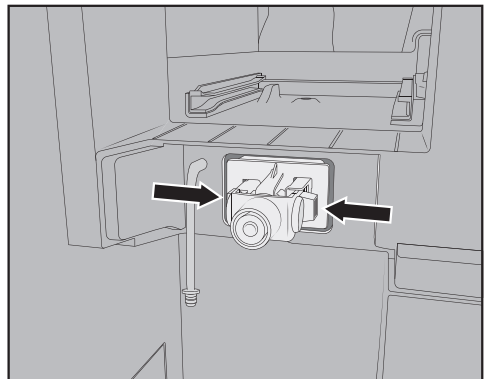

- Press the catches on the left and right of the milk valve holder and pull the holder forwards to remove it.

## Cleaning and care

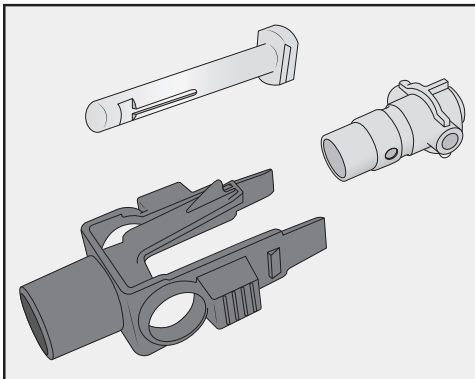

- Dismantle the holder and the silicone seal.

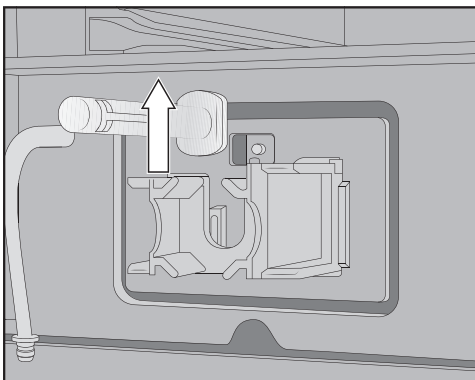

- Lift out the stainless steel stem.

### Cleaning the milk valve

The milk valve cover is not dishwasher-safe. Cleaning in the dishwasher can damage the milk valve cover. Clean the milk valve cover **by hand** only.

Do **not** switch on the coffee machine while the milk valve is removed.

- Clean all parts of the milk valve by hand.

**Useful tip:** To clean the components of the milk valve particularly thoroughly, clean them occasionally in the dishwasher (Exception: milk valve cover).

If there are any dry milk residues on the front, soak the stainless steel stem in warm water and a little washing-up liquid.

### Fitting the milk valve

Do **not** switch on the coffee machine while the milk valve is removed.

- Slide in the stainless steel stem from above.
- Fit the silicone seal in the milk valve holder.

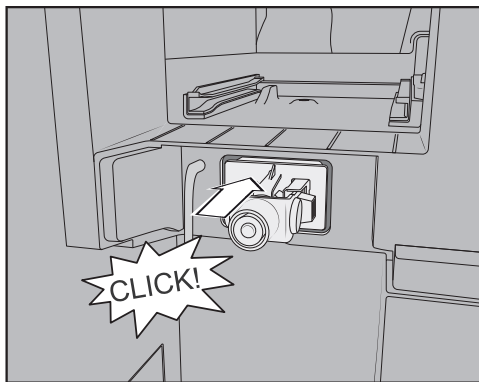

- Fit the holder with the silicone seal until it clicks into position.



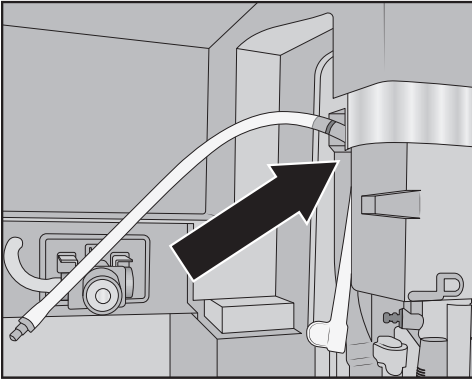

- Connect the angular moulded hose to the longer milk pipework. Start by fitting the moulded hose to the top of the central spout. The black connecting piece should point towards the rear.
- Then, connect the bottom end of the moulded hose to the dispensing unit.
- Insert the milk pipework into the milk valve on the left and right-hand sides. Push the connecting pieces into the silicone seal as far as they will go.
- Check whether the milk pipework sits comfortably against the housing and the cover is easy to refit.

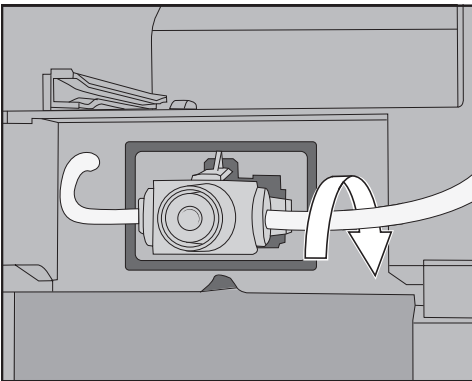

**Useful tip:** If necessary, turn the milk pipework on the right connecting piece towards the back.

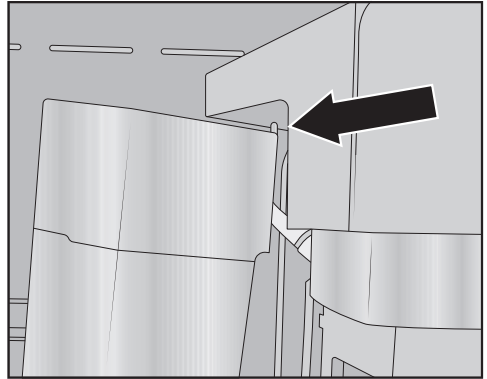

- Fit the milk valve cover: to do this, place the pin in the top right corner and swing the cover towards the rear until it closes flush.
- Refit the bean container on the left and the maintenance container in the coffee machine.
- Refit the central spout stainless steel cover.
- Close the appliance door.

You can now switch the coffee machine on again.

### Cleaning the bean containers

 **Damage due to incorrect use and cleaning.**

If the bean containers are immersed in water, it may result in malfunctions. Parts may break off during dismantling or mechanical components may not function correctly after reassembly.

Do not dismantle the bean containers.

Do not immerse the bean containers in liquids, e.g. washing-up liquid solution.

## Cleaning and care

Coffee beans contain oils which can deposit on the walls of the bean containers and hinder the flow of the beans. Therefore, clean the bean containers at least once a month with a soft cloth.

If required, you can clean the lids of the bean containers **by hand** with warm water and a little washing-up liquid. Dry the lids thoroughly before refitting them on the bean containers.

- Open the appliance door.
- Remove the bean containers on the left and right from the coffee machine.
- Clean the bean container chutes in the machine.

**Useful tip:** Use a vacuum cleaner to remove any coffee grounds from the interior of the machine.

- Remove the lids and empty the bean containers.

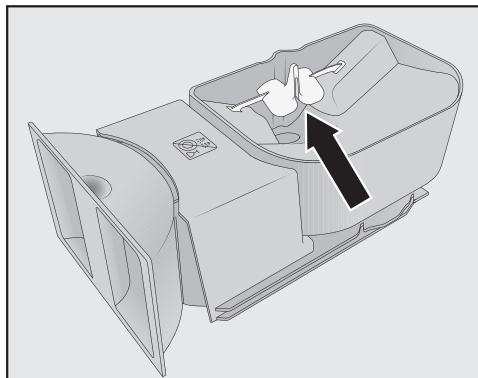

Do not remove the components which assist the flow of beans (see arrow).

- Clean the bean containers and their lids **by hand** with a slightly damp cloth.

- Dry all parts thoroughly before filling the bean containers with coffee beans again.
- Refit the lids.
- Push the bean containers back into the coffee machine.
- Close the appliance door.

### Removing the brew unit and cleaning by hand

The moving parts of the brew unit are lubricated. Cleaning agents will damage the brew unit.

Clean the brew unit by hand only under warm running water. **Do not use washing-up liquid or any other cleaning agent.**

Remove and clean the brew unit **once a week**. Also clean the area underneath the brew unit once a week.

### Removing the brew unit

When you have removed the brew unit, do **not** change the position of the handle on the brew unit. Otherwise the brew unit cannot be refitted.

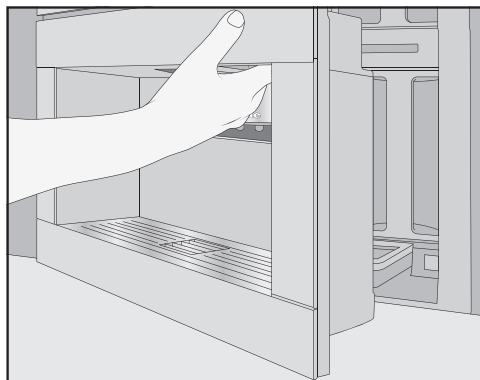

- Open the appliance door.

- Remove the water container.

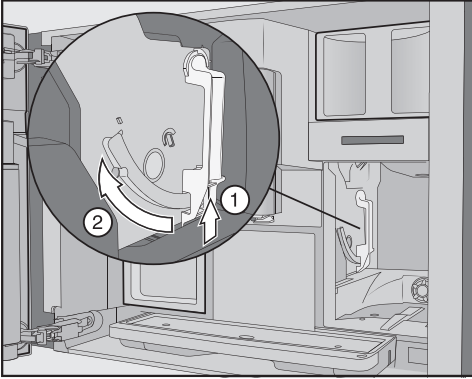

- Press the button under the handle of the brew unit ① and, whilst doing so, turn the handle to the front ②.

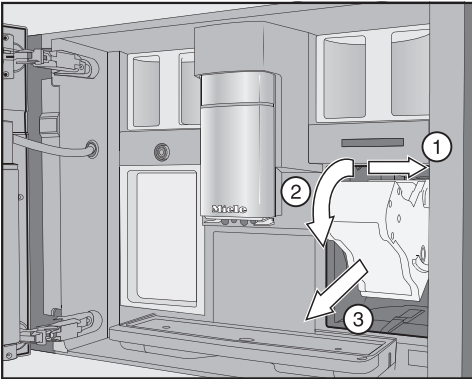

- Pull the brew unit to the side ① first and then pull out to the front ③. Tilt the brew unit forwards ②.

If you cannot remove the brew unit or can only do so with difficulty, the brew unit is not in the correct position (See "Problem solving guide").

## Cleaning the brew unit

The moving parts of the brew unit are lubricated. Cleaning agents will damage the brew unit.

Clean the brew unit by hand only under warm running water. **Do not use washing-up liquid or any other cleaning agent.**

- Clean the brew unit **by hand under warm running water** without using washing-up liquid or any other cleaning agent.

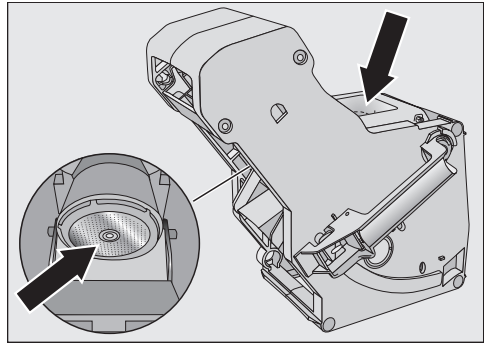

- Wipe any remaining coffee residues from the filters. One filter is located in the funnel. The other filter is located to the left of the funnel.
- Dry the funnel to prevent ground coffee sticking to it the next time a coffee is prepared.

# Cleaning and care

## Cleaning the interior of the machine

- Use your vacuum cleaner to remove dry coffee grounds.

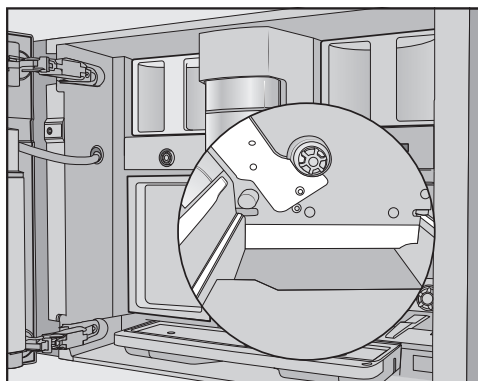

- Clean the niche of the brew unit with a damp, clean cloth. Clean the areas marked in white in the illustration, e.g. around the drive shaft, especially well.

## Refitting the brew unit

- Proceed in the reverse order to insert: push the brew unit back into the coffee machine. Tilt the brew unit forwards a little when doing this.

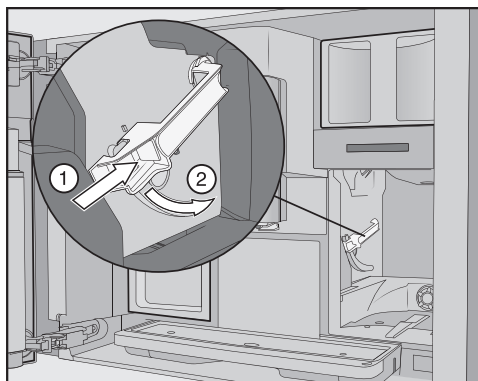

- Press the button under the handle of the brew unit ① and, whilst doing so, turn the handle to the rear ②.

**Useful tip:** If the handle of the brew unit cannot be turned, press firmly on the side of the brew unit.

- Push the water container into the coffee machine.

Coffee powder falls onto the drip tray when the brew unit is removed and refitted.

- Remove the drip tray and clean the lid.
- Push the drip tray back into the coffee machine.
- Close the appliance door.

## Cleaning the interior, the inside of the appliance door and the drip catcher

Clean the interior and the appliance front as part of the normal cleaning process. For example, clean the area underneath the water container when the water container has been removed.

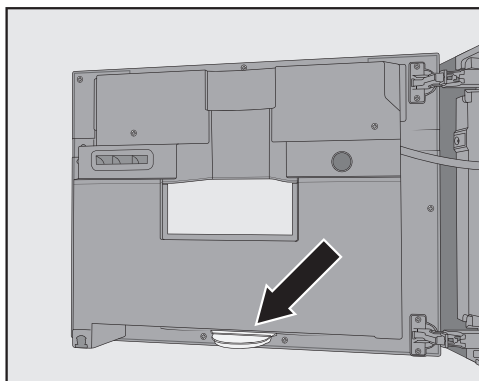

At the bottom of the inside of the appliance door there is a drip catcher.

Remove and empty the drip catcher regularly. The drip catcher is dishwasher-safe.

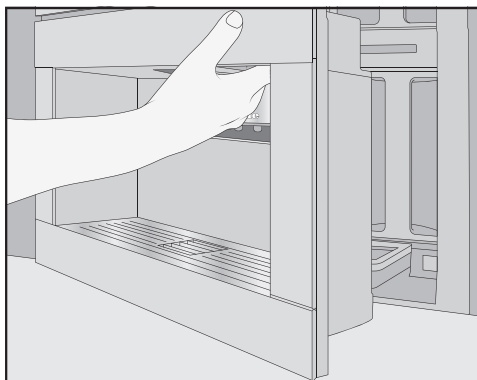

- Open the appliance door.
- Remove and clean the drip catcher.
- Remove the following parts from the interior of the machine:
  - Water container
  - Drip tray
  - Maintenance container
  - Brew unit
  - Bean containers

**Useful tip:** Use your vacuum cleaner to remove dry ground coffee residues.

- Clean the interior and the inside of the appliance door by hand with a slightly damp, clean sponge or microfibre cloth.
- Then dry the interior and the appliance door with a soft cloth.
- Refit all parts, including the drip catcher.
- Close the appliance door.

### Cleaning the appliance front

If soiling is not removed promptly, it could cause the surface to alter or discolour.

Remove any soiling from the front of the appliance straight away.

Make sure that water cannot get behind the display.

Clean the appliance front after manual descaling. Wipe up any spillages of descaling agent as soon as possible.

**Useful tip:** Open the appliance door before cleaning the control panel. This will avoid operating errors.

- Clean the appliance front with a slightly damp, clean sponge or a microfibre cloth.
- After cleaning, wipe the surfaces dry using a soft cloth.

**Useful tip:** You can also clean the appliance front with the Miele all purpose microfibre cloth.

### Maintenance programmes

The coffee machine has the following maintenance programmes:

- Rinse the appliance
- Rinse the milk pipework
- Clean the milk pipework\*
- Degrease the brew unit\*
- Descale the appliance\*

\* If you have not fitted a cleaning cartridge and automatic cleaning has been switched off, you will need to carry out this maintenance programme manually.

In addition, depending on usage patterns and the water used, the pipework of the coffee machine will

## Cleaning and care

---

need to be descaled manually at regular intervals, even if a descaling cartridge is fitted and automatic descaling is switched on.

### Opening the Maintenance menu

The drinks menu is displayed.

- Touch the ↶ sensor.
- Select Maintenance.

You can now start the required maintenance programme.

### Rinsing the appliance

If coffee has been dispensed, the coffee machine will rinse the coffee pipework automatically before switching off. You can also start Rinse the appliance manually.

### Rinsing the milk pipework

If you have prepared a drink using milk, the coffee machine will automatically rinse the milk pipework after a few minutes. You can also start Rinse the milk pipework manually.

### Cleaning the milk pipework

You can carry out the maintenance programme using the Miele cleaning cartridge or the cleaning agent for milk pipework (sachets with powder cleaning agent). The maintenance programme lasts for approx. 20 minutes.

If you have switched on automatic cleaning and fitted a ready-to-use cleaning cartridge, Clean the milk pipework will be carried out using the cleaning cartridge.

### Cleaning the milk pipework with the cleaning cartridge

In addition to automatic cleaning, you can start the maintenance programme, for example, to clean the milk pipework after intensive use.

The Maintenance menu is shown in the display.

- Touch Clean the milk pipework.
- Follow the instructions in the display.

### Cleaning the milk pipework with the cleaning agent for milk pipework (sachets)

If automatic cleaning is switched off, the milk pipework must be cleaned after 15 days at the latest. Messages appear in the display to prompt you to clean.

For optimum cleaning results, we recommend Miele Cleaning agent for milk pipework.

The Cleaning agent for milk pipework has been specially developed for use with Miele coffee machines and prevents subsequent damage.

You require 2 sachets of the Cleaning agent for milk pipework for each cleaning process.

It is available to order from the Miele online shop or directly from Miele (see the end of this booklet for contact details).

Clean the milk pipework appears in the display.

- Confirm the message with *OK*.
- Follow the instructions in the display.

When Fill water container with lukewarm water and cleaning agent up to the  symbol and insert. Close the door. **appears** in the display, proceed as follows.

- Open **2** sticks of the Cleaning agent for milk pipework and empty the contents into the water container.

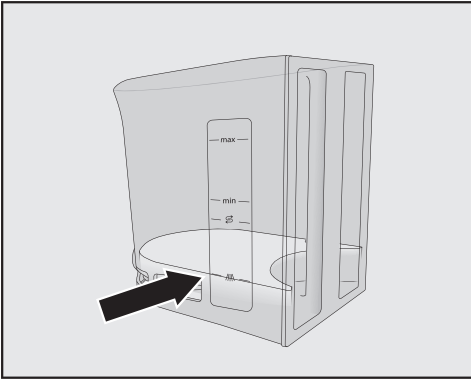

- Fill the water container to the  $\frac{3}{1}$  marker with lukewarm water and stir the solution.

Follow the instructions for the mixing ratio. Do not fill the water container with too little water. Cleaning will otherwise not be completed.

- Refit the water container.
- Close the appliance door.
- Follow the instructions in the display.
- If prompted in the display, carefully rinse out the water container with clean water. Ensure that **no** cleaning agent is left in the water container. Fill the water container with clean tap water.

The cleaning process is finished when **Process finished** appears in the display.

## Degreasing the brew unit

The brew unit must be degreased regularly in order to ensure aromatic coffee and trouble-free operation of the coffee machine. Depending on the

natural oil content of the type of beans used, the brew unit can become blocked quite quickly.

You can carry out the maintenance programme using the Miele cleaning cartridge or the cleaning tablets for degreasing the brew unit. The maintenance programme lasts for approx. 10 minutes.

If you have switched on automatic cleaning and fitted a ready-to-use cleaning cartridge, Degrease the brew unit will be carried out using the cleaning cartridge.

If a Miele cleaning cartridge has not been fitted, Degrease the brew unit appears in the display after 200 portions.

- Confirm the message with **OK**.

This message will appear repeatedly until the brew unit is degreased.

## Degreasing the brew unit

The Maintenance menu is shown in the display.

- Touch **Degrease the brew unit**.

The maintenance programme will start.

- Follow the instructions in the display.

Remove the water container and the brew unit. Rinse the brew unit by hand and clean the interior of the machine. **appears in the display**.

# Cleaning and care

## Cleaning the brew unit and the interior

The moving parts of the brew unit are lubricated. Cleaning agents will damage the brew unit.

Clean the brew unit by hand only under warm running water. **Do not use washing-up liquid or any other cleaning agent.**

To ensure good tasting coffee and to prevent the formation of microbes in the machine, remove and clean the brew unit under running water once a week.

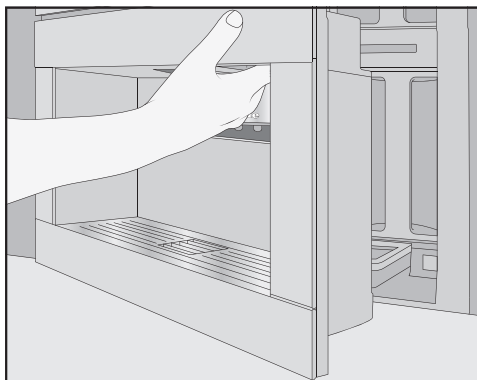

- Open the appliance door.
- Remove the water container.

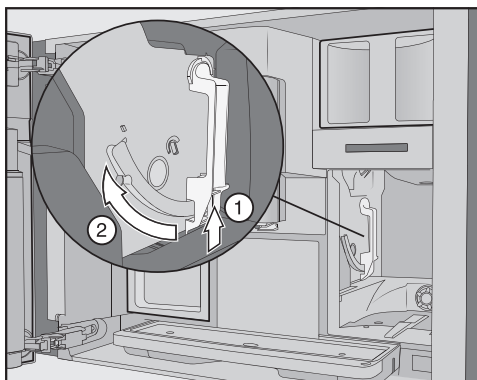

- Press the button under the handle of the brew unit ① and, whilst doing so, turn the handle to the front ②.

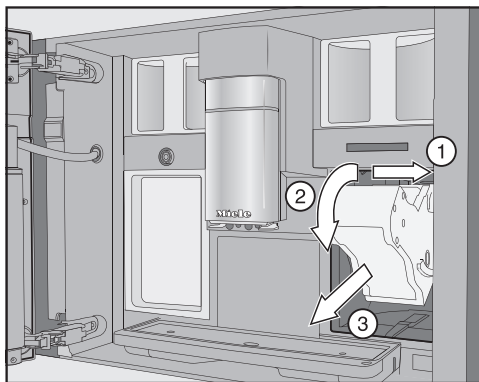

- Pull the brew unit to the side ① first and then pull out to the front ②. Tilt the brew unit forwards ③.

If you cannot remove the brew unit or can only do so with difficulty, the brew unit is not in the correct position (See "Problem solving guide").

When you have removed the brew unit, do **not** change the position of the handle on the brew unit. Otherwise the brew unit cannot be refitted.

- Clean the brew unit **by hand under warm running water** without using washing-up liquid or any other cleaning agent.



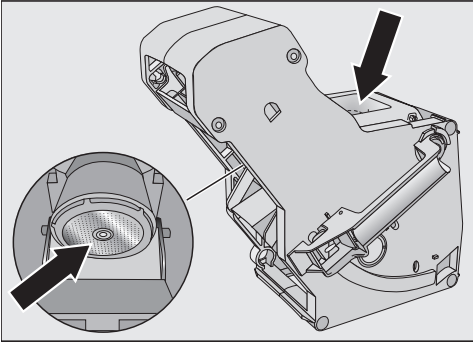

- Wipe any remaining coffee residues from the filters. One filter is located in the funnel and the other to the left of the funnel.

Coffee powder falls onto the drip tray when the brew unit is removed.

- Remove the drip tray and clean the lid.
- Clean the interior of the coffee machine (see also “Cleaning and care – Removing the brew unit and cleaning it by hand”). Use your vacuum cleaner to remove dry ground coffee residues.

## Adding a cleaning tablet to the brew unit

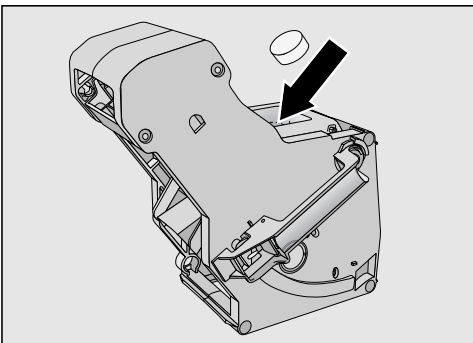

- Drop a cleaning tablet into the top of the brew unit (arrow).
- Push the brew unit with cleaning tablet back into the coffee machine.

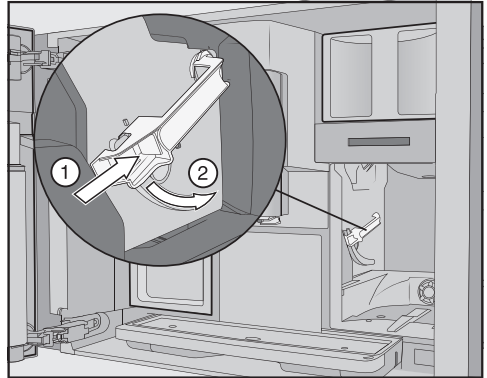

- Press the button under the handle of the brew unit ① and, whilst doing so, turn the handle to the rear ②.
- Push the water container and the drip tray, together with the waste container, back into the coffee machine.
- Close the appliance door.
- Follow the further instructions given in the display.

The cleaning process is finished when the drinks menu appears in the display.

## Descaling the appliance

Risk of damage from spilt descaling solution.  
Sensitive surfaces and/or natural floors can suffer damage.  
Wipe up any spillages of descaling agent immediately.

Limescale builds up in the coffee machine through use. How often the appliance needs to be descaled will depend on the water hardness level in your area. Limescale must be removed regularly.

## Cleaning and care

The appliance will guide you through the descaling process. Various messages will appear in the display, e.g. you will be prompted to empty the drip tray or fill the water container.

The descaling process is **essential** and takes approx. 35 minutes.

Even if you use automatic descaling, the pipework must be descaled at regular intervals using the Descale the appliance maintenance programme, depending on usage patterns.

If you have not fitted a descaling cartridge, you will also be reminded via the display to descale the coffee machine.

No. of uses until appliance needs descaling: 50 will appear in the display. The remaining number of drinks that can be made before descaling will appear in the display after each drink.

■ Confirm the message with *OK*.

When the number of remaining portions reaches 0, the appliance will lock out.

You can switch the coffee machine off if you do not want to carry out the descaling programme at this point. However, you cannot make any drinks until the machine has been descaled.

### Descaling after prompt appears in the display

Descal the appliance appears in the display.

■ Confirm the message with *OK*.

The process will start.

■ Follow the instructions in the display.

When Place 2 descaling tablets in the water container and fill it with lukewarm water up to the  appears in the display, proceed as follows.

For optimum descaling results, we recommend using the Miele descaling tablets.

The descaling tablets have been specially developed for Miele coffee machines.

Other descaling agents, which contain other acids besides citric acid and/or other undesirable substances, such as chlorides, may cause damage to the product. Moreover, the descaling result required cannot be guaranteed if the descaling solution was not of the appropriate concentration.

Miele descaling tablets are available to order from the Miele online shop or directly from Miele (see the end of this booklet for contact details).

You will need **2** descaling tablets for the descaling process.

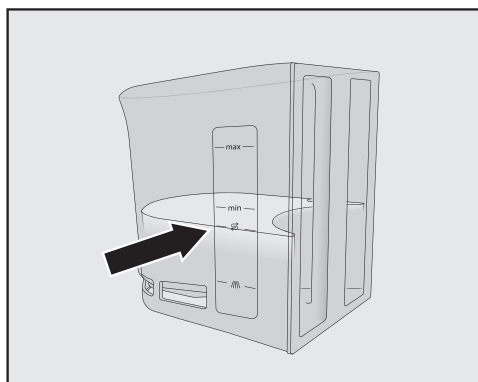

■ Fill the water container to the marker  with lukewarm water.

■ Add **2** Miele descaling tablets to the water container.

Follow the instructions for the mixing ratio carefully. It is important that you do not fill the water container with too much or too little water. Otherwise the descaling process will be cancelled prematurely.

### Carrying out descaling

- Push the water container back into the machine.
- Follow the further instructions given in the display.

When Rinse and refill the water container appears in the display:

- Remove the water container and rinse it thoroughly with clean water. Ensure that **no** descaling solution residue remains in the water container. Fill the water container with tap water.

The descaling process has finished when the drinks menu appears in the display.

# Automatic cleaning and descaling

---

Risk of damage from spilt cleaning and descaling solutions.

Sensitive surfaces and/or natural floors can suffer damage.

You can place the maintenance container under the central spout before switching off to collect the cleaning and descaling solutions.

Wipe up any spillages of cleaning and descaling agent.

When handling a descaling cartridge which has already been filled with water, ensure that the descaling solution does not come into contact with sensitive surfaces.

The coffee machine has automatic maintenance programmes for cleaning the milk pipework and the brew unit, as well as for descaling the machine. This is why the Miele cleaning cartridge and descaling cartridge are fitted in the coffee machine. If both types of maintenance programme are due to run on the same day, automatic cleaning will always be performed before automatic descaling (total time: approx. 35 minutes).

You can set the time for daily cleaning and descaling to start using the Maintenance timer.

The coffee machine will automatically determine the days when to carry out automatic descaling based on the usage pattern.

With automatic cleaning the milk pipework is cleaned and/or the brew unit is degreased. The coffee machine also determines the concentration of the cleaning solution and type of cleaning programme for automatic cleaning based on the number and type of drinks prepared.

If you do not make any drinks, the automatic maintenance programmes will not start.

Water is mixed with cleaning agent to form a solution for automatic maintenance programmes and this is then pumped through the pipework of the coffee machine. After a specific activation phase, the solution is rinsed out of the pipework and the machine can then be used as normal for making drinks.

During automatic cleaning and descaling you will hear rinsing noises, for example, at frequent intervals even though the appliance is switched off.

## What to ensure before and during automatic maintenance programmes

The coffee machine must be ready to use and the following conditions must be met:

- Ready-to-use cleaning and descaling cartridges are fitted.
- Automatic cleaning is switched on.
- The coffee machine must **not** be disconnected from the mains power supply during the automatic maintenance programmes.
- The drip tray, brew unit and central spout are fitted.
- When not using mains water connection: The water container is inserted and is filled with water at least up to the  marker.
- Carry out the instructions which appear in the display before switching off, e.g. Empty and refit the drip tray and the waste container.

# Automatic cleaning and descaling

- The appliance door is closed at time of starting.
- The coffee machine is switched off.

## Automatic cleaning

If you have made a drink containing milk, the milk pipework will be cleaned 4 days later at the latest.

If you have made a coffee, the brew unit will be degreased 15 days later at the latest.

Automatic cleaning takes approx. 25 minutes.

## Switching automatic cleaning on and off

Automatic cleaning is usually switched on when setting up the machine.

However, you can switch the Automatic cleaning on or off at any time.

The drinks menu is displayed.

- Touch the ↩ sensor.
- Select Settings and then Automatic cleaning.
- Select the setting you want and confirm with *OK*.

If automatic cleaning is switched on and coffee drinks and/or milk have already been prepared, the coffee machine will need to be manually cleaned once. This will remove milk residues and coffee oils and the counter will be reset.

## The Miele cleaning cartridge

For automatic cleaning, only use the Miele cleaning cartridge. These have been developed specifically for use in this coffee machine.

Please note that the Miele cleaning cartridge has a storage life of approx. one year after it has been placed in the machine for the first time.

Critical for the one-year storage life is the date on which the cleaning cartridge was fitted.

Do not fill the cleaning cartridge with other fluids or substances.

The Miele cleaning cartridge contains a cleaning agent that effectively removes milk residues and coffee oils.

The cleaning cartridge is sufficient for up to 3 months' cleaning, depending on usage. If you carry out manual cleaning more frequently, or prepare a lot of drinks, the time will reduce accordingly.

You can display the fill level of the cartridge as a segment bar under Settings | Info | Fill levels. As the fill level of the cartridge drops, various messages are displayed at regular intervals to remind you to purchase a new cartridge.

The first message appears when the cartridge is approx. 25% full.

Replacement cleaning cartridges are available to order from the Miele online shop or directly from Miele (see back cover for contact details).

# Automatic cleaning and descaling

If a cleaning cartridge is **not** fitted, an **empty** cartridge is fitted or an **expired** cartridge is fitted, the milk pipework and the brew unit need to be cleaned/degreased manually. To do this, the appropriate cleaning agent is required (see “Cleaning and care - Cleaning the milk pipework” and “Degreasing the brew unit”).

The cleaning cartridge can remain fitted even if it is not used for a long time or while being transported.

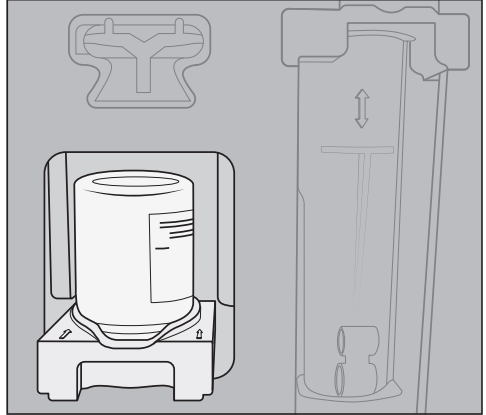

## Replacing the cleaning cartridge

Replacement cleaning cartridges are available to order from the Miele online shop or directly from Miele (see back cover for contact details).

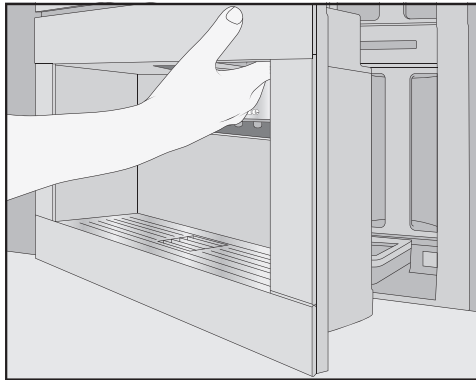

- Open the appliance door.
- Remove the maintenance container.

- Pull the holder with the cartridge forwards and remove both.
- Unscrew the cleaning cartridge from the holder.
- Dispose of the used cartridge with your household waste.

Sometimes cleaning agent residues dry on the holder in the form of white deposits. These cleaning agent residues will not affect the automatic cleaning programme. If necessary, you can wipe the deposits off with a damp cloth or clean the holder in the dishwasher.

- Remove the new cartridge from its packaging.
- Unscrew the cap.

The cap is no longer required.

# Automatic cleaning and descaling



- Screw the cleaning cartridge into the holder upside down.
- Push the holder with the cartridge into the coffee machine until it clicks into place.
- Refit the maintenance container.
- Close the appliance door.

## Automatic descaling

Automatic descaling takes approx. 12 minutes.

To ensure the longevity of components and a consistent environment free of limescale, the coffee machine needs to be manually descaled from time to time. The intervals are determined by your usage patterns and the water hardness level of your area. If you make a lot of coffees with milk, for example, you will need to descale the coffee machine more frequently with the descaling tablets.

## The Miele descaling cartridge

Only use the Miele descaling cartridge for the automatic descaling programme.

Please note that the Miele descaling cartridge has a storage life of approx. 1 year after it has been placed in the coffee machine and filled with water for the first time. Critical for the one-year storage life is the date on which the descaling cartridge was fitted and filled with water.

Do not use a descaling cartridge which has already been used in another Miele coffee machine. Your coffee machine will have no information about the fill level of this cartridge. The descaling effect may be insufficient and damage your coffee machine.

Do not fill the descaling cartridge with other fluids or substances.

The descaling agent comes in the form of tablets in the descaling cartridge. The cartridge is filled with water when it is placed in the coffee machine. The tablets gradually dissolve over time.

The Miele descaling cartridge will last for 7 to 12 months of automatic descaling, depending on how often the coffee machine is used.

You can display the fill level of the cartridge as a segment bar under Settings | Info | Fill levels. As the fill level of the cartridge drops, various messages are displayed at regular intervals to remind you to purchase a new descaling cartridge.

The descaling cartridge is available to order from the Miele online shop or directly from Miele Customer Service or your Miele specialist dealer.

# Automatic cleaning and descaling

If a descaling cartridge is **not** fitted, an **empty** cartridge is fitted or an **expired** cartridge is fitted, the coffee machine needs to be descaled using the Descale the appliance maintenance programme. To do this, the appropriate descaling agent is required (see “Cleaning and care – Descaling the appliance”).

The descaling cartridge can remain fitted even if the machine is not used for a long time. Remove the cartridge before transporting the coffee machine. However, please note the following:

- Once filled with water, the descaling cartridge has a maximum shelf life of 3 weeks outside of the coffee machine.
- It should be transported with care and upright. Avoid shaking it. Shaking or turning upside down reduces the storage life and damages the cartridge.
- The cartridge should be stored upright, in a dark place and at room temperature (16 – 38 °C).

## Replacing the descaling cartridge

### Removing the descaling cartridge

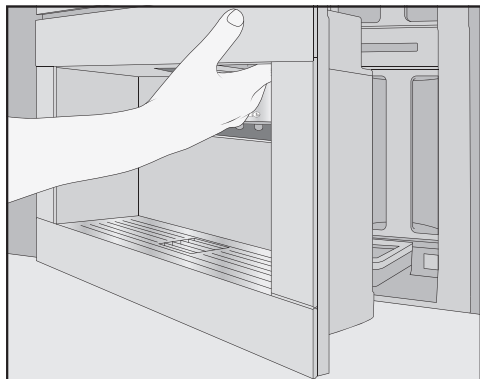

- Open the appliance door.
- Remove the maintenance container.

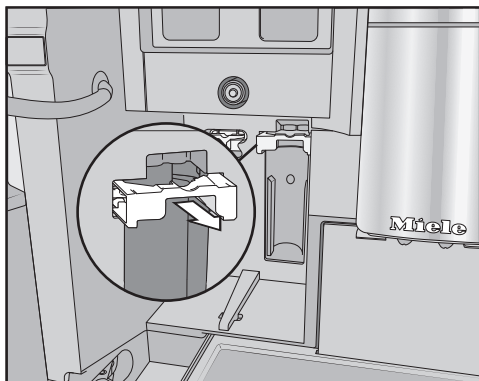

- Pull the cartridge holder forwards.
- Remove the cartridge.

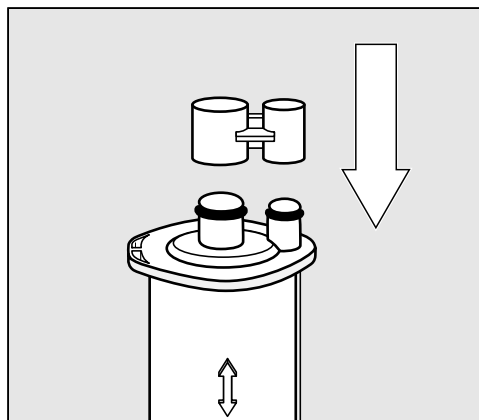

**Useful tip:** You can seal the descaling cartridge with the cap located on the cylinder of the cartridge. The cap can easily be released by snapping it off.

- Dispose of the empty cartridge with your household waste.

### Fitting the descaling cartridge

- Insert the cartridge and push it upwards as far as it will go.
- Push the cartridge holder back in and fit the maintenance container.



# Automatic cleaning and descaling

- Close the appliance door.
- Follow the instructions in the display.

The next time the coffee machine is switched off, the new descaling cartridge will also fill with water when the machine is rinsed. You will hear water being pumped into the cartridge at frequent intervals.

Wait until the coffee machine switches itself off. Do not force the machine to switch off.

## When not using a descaling cartridge

If you do not want to fit a descaling cartridge, the system must be sealed with the plug.

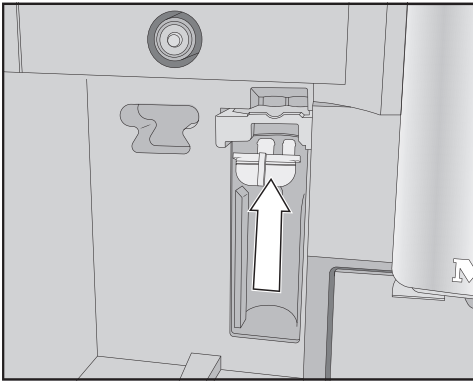

- Insert the plug in place of the cartridge.

## Maintenance timer

You can select the start time for the automatic maintenance programmes under Maintenance timer.

Please note that the automatic maintenance programmes can take a maximum of around 35 minutes to run.

You can set various start times for the weekend and the week from Monday to Friday.

## Setting the Maintenance timer

The drinks menu is displayed.

- Touch the ↶ sensor.
- Select Maintenance.
- Select Maintenance timer.
- Change the settings as required.
- Confirm with *OK*.

The start time is saved. The automatic maintenance programmes will start at the required start time from now on.

## Cancelling automatic cleaning and descaling

You can cancel the automatic cleaning programme during the activation phase.

If the automatic cleaning programme is not performed **five times** in a row, the dispensing of drinks is blocked. You will only be able to make drinks again once the brew unit has been degreased and/or the milk pipework has been cleaned.

- Touch the On/Off ⏻ sensor.

The time left in hours is shown in the display.

- Touch *Cancel*.

The cleaning or descaling solution is rinsed out of the pipework. Rinsing can take up to 5 minutes. You can now make drinks.

## Problem solving guide

---

Many malfunctions and minor faults that can occur in daily operation can be corrected without contacting Miele. This will save you time and money because you will not need a service call.

You can find information on how to remedy faults yourself at [www.miele.com.au/service](http://www.miele.com.au/service) or [www.miele.co.nz/service](http://www.miele.co.nz/service) and on the Miele website.

Please note, however, that a call-out charge will be applied to unnecessary service visits where the problem could have been rectified as described in these operating instructions.

### Messages in the display

Error messages must be confirmed with *OK*. Otherwise the message may reappear in the display even though the problem has been remedied.

Follow the instructions which appear in the display to remedy the problem.

If the fault message appears again in the display, contact Miele.

| Problem   | Possible cause and remedy  |
|---|--|
| <b>F1, F2,<br/>F80, F82,<br/>F353, F354</b>         | There is an internal fault.<br>■ Switch the coffee machine off. Wait for approximately one hour before switching the machine back on again.  |
| <b>F74, F77<br/>F225, F226<br/>F235, F353, F354</b> | There is an internal fault.<br>■ Switch the coffee machine off. Wait for approximately 2 minutes before switching the machine back on again. |

## Problem solving guide

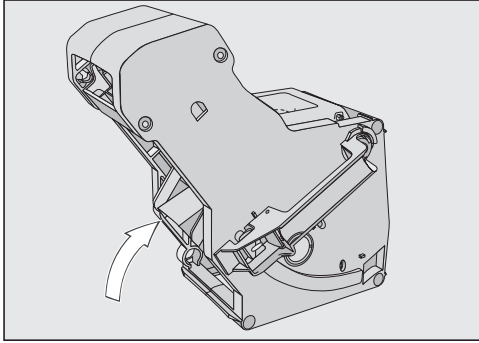
| Problem   | Possible cause and remedy   |
|---|---|
| <p><b>F73 or</b><br/>Check the brew unit</p>  | <p>The brew unit cannot be positioned correctly or it is dirty. Coffee powder cannot be pressed.</p> <ul style="list-style-type: none"> <li>■ Check whether you can remove the brew unit.</li> <li>■ When you are able to remove the brew unit, rinse it under running water.</li> </ul>  <ul style="list-style-type: none"> <li>■ Push the coffee ejector of the brew unit into the correct position (see diagram).</li> <li>■ Do <b>not</b> insert the brew unit. Insert the water container and close the appliance door. Switch the coffee machine on.</li> </ul> <p>This will initialise the brew unit motor and put it back into the start position.</p> <ul style="list-style-type: none"> <li>■ <b>When</b> Insert the brew unit appears in the display, open the appliance door and put the brew unit back in the machine.</li> <li>■ If you are unable to remove the brew unit, switch off the coffee machine. Wait for approximately 2 minutes before switching the machine back on again.</li> </ul> |
| <p><b>A manual maintenance programme is cancelled early and</b> Push the water container in until it engages <b>appears in the display.</b></p> | <p>The water container was not correctly filled and refitted.</p> <ul style="list-style-type: none"> <li>■ Check that you have filled to the correct marker.</li> </ul> <p>The symbols on the water container indicate the required water level for the<br/>           Descale the appliance: ☞ and Clean the milk pipework: ☞<br/>           maintenance programmes.</p> <ul style="list-style-type: none"> <li>■ Fill the water container to the marker and start the process again.</li> </ul>   |

## Problem solving guide

| Problem  | Possible cause and remedy  |
|--|--|
| Check water intake and empty the water container   | <p>Mains water intake is not working.</p> <ul style="list-style-type: none"> <li>■ Check whether the inlet hose is kinked or the tap is not turned on completely.</li> <li>■ Remove and empty the water container.</li> <li>■ Fit the empty water container in the coffee machine.</li> </ul> <p>Please wait. Water container filling. appears in the display. The water container is filled.</p> <p>If you want to switch off the mains water connection, fill the water container and place it in the machine. Now you can select Mains water   Off in the Settings menu.</p>    |
| <b>F233</b>  | <p>The cup rim sensor is not inserted or is incorrectly inserted.</p> <p>If the central spout is moving upwards and the cup rim sensor is bumped, e.g. with a cup, the cup rim sensor loses its reference position.</p> <ul style="list-style-type: none"> <li>■ Confirm the message with <i>OK</i>.</li> <li>■ Refit the cup rim sensor.</li> </ul> <p>Cup detection is deactivated until the next time the coffee machine is switched on and the central spout remains in the highest position. Cup detection is initialised again the next time the machine is switched on.</p> |
| <b>F355, F357– F362</b>                            | <p>The bean system must be set up again, e.g. coffee beans have possibly got jammed.</p> <ul style="list-style-type: none"> <li>■ Open the appliance door and remove both bean containers from the coffee machine.</li> <li>■ Close the appliance door.</li> </ul> <p>The bean system will be initialised.</p> <ul style="list-style-type: none"> <li>■ Follow the instructions in the display.</li> </ul>   |
| <b>F 307 or</b> Remove the milk valve and clean it | <p>The milk valve is faulty.</p> <ul style="list-style-type: none"> <li>■ Remove and clean the milk valve (see “Cleaning and care – Removing and cleaning the milk valve”).</li> </ul>   |

## Unusual performance of the coffee machine

| Problem   | Possible cause and remedy  |
|---|--|
| <b>The display remains dark when the coffee system is switched on with the On/Off ① sensor.</b> | The On/Off ① sensor was not touched for long enough.<br>■ Touch and hold the On/Off ① sensor for at least 3 seconds.   |
|   | The plug is not properly inserted into the socket.<br>■ Insert the plug into the socket correctly.   |
|   | The mains fuse has tripped because the coffee machine, mains voltage or another appliance is defective.<br>■ Switch off at the wall socket and remove the plug.<br>■ Contact a qualified electrician or Miele. |
| <b>The lighting remains off after the coffee machine is switched on.</b>                        | The lighting has been switched off.<br>■ Switch the lighting on (see "Settings - Lighting").   |
|   | The lighting is faulty.<br>■ Call Miele.   |
| <b>The time of day is displayed, but the ☀ sensor and the proximity sensor do not react.</b>    | This is not a fault. The QuickTouch function is switched off. Select the Display   QuickTouch   On setting for the ☀ sensor and the proximity sensor to react even if the coffee machine is switched off.      |
| <b>The coffee machine does not react to operating the display.</b>                              | There is a fault.<br>■ Touch and hold the On/Off ① sensor until the display switches off and the appliance restarts.   |
| <b>The coffee machine switches off suddenly.</b>  | The factory set switch-off time (20 minutes) or the switch-off time you have programmed has been reached.<br>■ If required, you can select a new switch-off time (see "Settings - Timer").                     |
|   | The plug is not properly inserted into the socket or the socket is not switched on.<br>■ Insert the plug into the socket correctly and switch on.  |
| <b>The sensors do not respond to touch. The appliance cannot be operated.</b>                   | There is an internal fault.<br>■ Disconnect the electricity supply by switching off at the wall socket and withdrawing the plug, or switching off the mains circuit breaker.                                   |

## Problem solving guide

| Problem   | Possible cause and remedy  |
|---|--|
| <p><b>A fan can be heard even though no drinks are being prepared and the coffee machine is switched off.</b></p>                       | <p>This is not a fault.<br/>Once a drink has been dispensed or the machine has been switched off, the internal fan will continue to run until the interior is sufficiently dehumidified.</p>   |
| <p><b>The brew unit cannot be removed from the coffee machine.</b></p>  | <p>The brew unit drive is not in the correct position.</p> <ul style="list-style-type: none"> <li>■ If necessary, move the handle on the brew unit back to the start position.</li> <li>■ Close the appliance door.</li> <li>■ Switch the coffee machine off.</li> <li>■ Wait approx. 1 minute before switching on the coffee machine.</li> </ul> <p>This will initialise the brew unit drive and put it back into the start position.</p> <ul style="list-style-type: none"> <li>■ If necessary, repeat these steps.</li> </ul>   |
| <p><b>Drink preparation is cancelled prematurely even though a cup or glass is located under the central spout.</b></p>                 | <p>This is not a fault.<br/>If the opening of the cup or glass is so wide, e.g. as with a large mug, that the cup rim sensor cannot detect the rim, the drink is cancelled. Use a different cup or glass, or position it in such a way that its rim can be detected.</p>   |
| <p><b>The coffee machine does not switch itself on, although the <small>On at</small> setting has been activated for the timer.</b></p> | <p>The system lock has been activated.</p> <ul style="list-style-type: none"> <li>■ Deactivate the system lock.</li> </ul> <hr/> <p>The current day of the week has not been selected.</p> <ul style="list-style-type: none"> <li>■ Check the timer settings and change these if necessary.</li> </ul> <hr/> <p>The machine was not used after being switched on automatically three times in succession (holiday mode).</p> <ul style="list-style-type: none"> <li>■ Switch the machine on and dispense a drink.</li> </ul> <hr/> <p>The coffee machine does not switch on with the <small>On at</small> timer while automatic descaling is being carried out. This is not a fault. Select a different timer setting.</p> |
| <p><b>You are preparing hot water or tea and instead of water, steam is dispensed.</b></p>  | <p>The altitude is possibly set incorrectly.</p> <ul style="list-style-type: none"> <li>■ Change the altitude setting (Settings   Altitude).</li> <li>■ You can also change the temperature settings if necessary (Drink parameters).</li> </ul>   |

## Problem solving guide

| Problem   | Possible cause and remedy   |
|---|---|
| The display is hard to see or not able to be read.                                    | The display brightness is set too low.<br><ul style="list-style-type: none"> <li>■ Change this setting.</li> </ul>  |
| The display lights up but the coffee machine does not heat up and no drinks are made. | The Demo mode of the coffee machine for Miele Experience Centres and Chartered Agents has been activated.<br><ul style="list-style-type: none"> <li>■ Deactivate Demo mode (see “Settings”).</li> </ul> |

### Faults with automatic cleaning and/or descaling

| Problem   | Possible cause and remedy   |
|---|---|
| After switching on, a message appears informing you that automatic cleaning and/or descaling could not be carried out.                | The coffee machine was not ready for operation: all removable parts, such as the water container, drip tray, brew unit and central spout, must be installed.<br>The water container was not filled with drinking water at least up to the descaling symbol  .<br>The appliance door was not closed.<br><ul style="list-style-type: none"> <li>■ Confirm the message with <i>OK</i>.</li> <li>■ Make sure that the coffee machine is ready to use before the next automatic cleaning and/or descaling process.</li> </ul> |
|   | The coffee machine was not switched off at the start time.<br>The automatic maintenance programmes are only started if the coffee machine is switched off.<br><ul style="list-style-type: none"> <li>■ Confirm the message with <i>OK</i>.</li> <li>■ Change the start time if necessary.</li> </ul>  |
| Descal the appliance appears in the display even though a descaling cartridge which is ready to use is fitted. Drinks cannot be made. | Depending on the water hardness level in your area and your usage patterns, the coffee machine needs to be descaled using the maintenance programme occasionally.<br>For this you will need to use Miele descaling tablets.<br><ul style="list-style-type: none"> <li>■ Descale the coffee machine using the maintenance programme (see “Cleaning and care - Descaling the appliance”).</li> </ul>  |

## Problem solving guide

| Problem  | Possible cause and remedy  |
|--|--|
| <p><b>After switching on, one of the following messages appears:</b><br/>Automatic cleaning could not be carried out. Start automatic cleaning (duration min.) now? Otherwise automatic cleaning will be permanently switched off.</p> <p><b>Or:</b><br/>Automatic maintenance could not be carried out. Carry out the automatic cleaning part of the automatic maintenance programme (duration min.) now? Otherwise the automatic cleaning part of the automatic maintenance programme will be permanently switched off.</p> <p><b>Drinks cannot be made.</b></p> | <p>Automatic cleaning could not be carried out five times.</p> <p>If you still want the coffee machine to clean the milk pipework and degrease the brew unit automatically:</p> <ul style="list-style-type: none"> <li>■ Make sure that the coffee machine is ready to use for automatic maintenance (see "Automatic cleaning and descaling").</li> <li>■ Touch <i>OK</i> to start automatic cleaning.</li> </ul> <p>If you select <i>No</i> and therefore switch off automatic cleaning, you must manually clean the milk pipework and degrease the brew unit (see "Cleaning and care"). To do this, you require the Cleaning agent for milk pipework and tablets for degreasing the brew unit.</p> |

## Unsatisfactory results

| Problem                                     | Possible cause and remedy   |
|---|---|
| <p><b>The coffee is not hot enough.</b></p> | <p>The cup has not been pre-heated.<br/>The smaller the cup and the thicker its walls, the more important it is to pre-heat it.</p> <ul style="list-style-type: none"> <li>■ Pre-heat the cup, for example with hot water.</li> </ul> |
|   | <p>The brewing temperature has been set too low.</p> <ul style="list-style-type: none"> <li>■ Set a higher brewing temperature.</li> </ul>  |
|   | <p>The filters in the brew unit are blocked.</p> <ul style="list-style-type: none"> <li>■ Remove the brew unit and clean it by hand.</li> <li>■ Degrease the brew unit.</li> </ul>  |



## Problem solving guide

| Problem   | Possible cause and remedy   |
|---|---|
| <p><b>The coffee grinder makes a louder noise than usual.</b></p>   | <p>The coffee bean container has become empty during the grinding process.</p> <ul style="list-style-type: none"> <li>■ Fill the coffee bean container with fresh beans.</li> </ul> <p>There may be foreign objects such as plastic or stones in amongst the coffee beans.</p> <ul style="list-style-type: none"> <li>■ Switch the coffee machine off immediately. Call Miele.</li> </ul>   |
| <p><b>The coffee flows too quickly into the cup.</b></p>  | <p>The coffee is too coarsely ground.</p> <ul style="list-style-type: none"> <li>■ Set the grinder to a finer setting.</li> </ul>   |
| <p><b>The coffee drink is dispensed too slowly into the cup.</b></p>  | <p>The brew unit is blocked.</p> <ul style="list-style-type: none"> <li>■ Degrease the brew unit (see "Cleaning and care - Degreasing the brew unit and cleaning the interior").</li> </ul>   |
| <p><b>There is no crema on the coffee or espresso.</b></p>  | <p>The coffee beans are no longer fresh. If roasted coffee beans are stored open for too long, the carbon dioxide gradually escapes from the coffee beans. The crema is therefore no longer formed during dispensing. Of course, you can still use the coffee beans.</p>  |
| <p><b>The coffee tastes weak. The coffee grounds in the waste container are sludgy and grainy.</b></p>            | <p>Insufficient coffee beans are getting into the grinder and less coffee is being brewed.</p> <p>Have you used a dark roast?</p> <p>This type of coffee bean is often oily. These oils can cling to the inside of the coffee bean containers and hinder the flow of beans.</p> <p>Are you using a type of coffee with very large beans or different sized beans?</p> <p>The beans are possibly getting wedged or jammed and forming "bean bridges".</p> <ul style="list-style-type: none"> <li>■ Clean the coffee bean containers more often if you are using darker, more oily coffee beans.</li> <li>■ Pull the bean containers out a little and shake them if you are using coffee with very large beans or different sized beans.</li> <li>■ Trying using a different type of coffee.</li> </ul> |
| <p><b>Coffee is not being dispensed from both spouts evenly. Milk may be sputtering when being heated up.</b></p> | <p>Coffee deposits in the central spout are obstructing dispensing.</p> <ul style="list-style-type: none"> <li>■ Dismantle the central spout and clean the parts - except for the stainless steel cover - in the dishwasher.</li> </ul> <p>This cleaning process should be carried out <b>once a week</b>.</p>  |

## Problem solving guide

| Problem  | Possible cause and remedy  |
|--|--|
| <p><b>The consistency of the milk froth is unsatisfactory.</b></p>           | <p>The milk temperature is too high. Good milk froth can only be achieved with cold milk (below 10 °C).</p> <ul style="list-style-type: none"> <li>■ Check the temperature of the milk in the milk flask.</li> </ul> <hr/> <p>The milk pipework is blocked and/or the milk valve is dirty.</p> <ul style="list-style-type: none"> <li>■ Remove and clean the milk valve.</li> </ul>  |
| <p><b>Coffee flows very slowly or even drips from the central spout.</b></p> | <p>The brew unit is blocked because the coffee machine has been used very intensively and/or the brew unit was not removed regularly and cleaned by hand.</p> <ul style="list-style-type: none"> <li>■ If a cleaning cartridge is fitted, first switch off Automatic cleaning (Settings   Automatic cleaning).</li> <li>■ Carry out the Degrease the brew unit maintenance programme using one cleaning tablet (see “Cleaning and care - Degreasing the brew unit and cleaning the interior”).</li> </ul> <div data-bbox="400 703 878 1046" data-label="Image"> </div> <ul style="list-style-type: none"> <li>■ Clean the brew unit filters in particular very carefully.</li> <li>■ Switch on Automatic cleaning, if necessary, before starting drink preparation again.</li> </ul> <p>Otherwise the Clean the milk pipework and Degrease the brew unit maintenance programmes must be started again.</p> |

You can find information on how to remedy faults yourself and about Miele spare parts at [www.miele.com.au/service](http://www.miele.com.au/service) or [www.miele.co.nz/service](http://www.miele.co.nz/service).

### Contact in case of fault

In the event of any faults which you cannot remedy yourself, please contact Miele.

You can book a Miele customer service call-out online at [www.miele.com.au/service](http://www.miele.com.au/service) or [www.miele.co.nz/service](http://www.miele.co.nz/service).

Contact information for Miele can be found at the end of this booklet.

Please quote the model and serial number of your appliance when contacting Miele. This information can be found on the data plate.

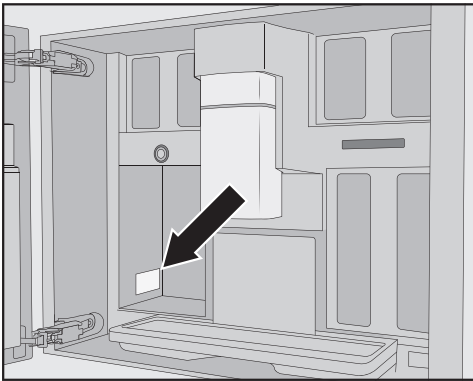

### Warranty

The manufacturer's warranty for this appliance is 2 years.

For further information, please refer to your warranty booklet.

## Accessories

---

These products and other useful accessories can be ordered via the Miele webshop or directly from Miele (see back cover for contact details).

- **Original Miele all purpose microfibre cloth**  
For removing finger marks and light soiling
- **Cleaning agent for milk pipework**  
For cleaning the milk system
- **Cleaning tablets**  
For degreasing the brew unit
- **AutoCleaner**  
for automatically cleaning the milk pipework and brew unit
- **Descaling cartridge**  
for automatic descaling
- **Descaling tabs**  
For manual descaling

## Mains water connection

 Risk of injury and damage due to incorrect connection.

Failing to connect the appliance correctly can result in personal injury and/or material damage.

The appliance may only be connected to the water supply by a suitably qualified technician.

 Danger to health and property due to contaminated water.

The quality of the water used must conform to the requirements for drinking water in the country in which the coffee machine is being used.

Connect the coffee machine to the mains water supply.

Connection to the water supply must comply with the applicable regulations in the country where the appliance is being installed. This appliance must be installed in accordance with AS/NZS 3500.1 and AS/NZS 3500.2. Back flow prevention is already integrated in the appliance.

Connect the coffee machine directly to the mains water supply.

Avoid connecting the coffee machine to a water supply in which the water might stagnate. Otherwise the taste of prepared drinks will be adversely affected.

The coffee machine complies with local and national regulations.

The coffee machine may only be connected to a cold water supply.

The water connection pressure needs to be between 100 and 1000 kPa.

A tap must be provided between the stainless steel hose and the household water supply to ensure that the water supply can be cut off if necessary. The tap must be easily accessible after the coffee machine has been built in.

## Connecting the stainless steel hose to the coffee machine

Only use the stainless steel hose supplied. The stainless steel hose must not be shortened, extended or replaced by another hose. Old or used hoses must not be connected to the coffee machine.

The stainless steel hose must only be replaced by an original Miele spare part. A stainless steel hose which is suitable for use with drinking water is available to order from Miele (see back cover for contact details).

The length of the stainless steel hose supplied is 1.5 m.

- Remove the cover from the mains water connection on the back of the coffee machine.
- Take the **angled** end of the stainless steel hose and check whether there is a washer. Fit a washer if necessary.
- Screw the stainless steel hose coupling nut onto the threaded union.
- Ensure that it is screwed into position correctly and watertight.

# Installation

## Connecting the water supply

⚠ Disconnect the coffee machine from the mains power supply before connecting it to the water supply. Turn off the water supply at the tap before connecting the coffee machine to the water supply.

The tap must be easily accessible after the machine has been built in.

To connect the coffee machine to the water supply, a tap with a 3/4" connection is required.

- Check that a washer is present. Fit one if necessary.

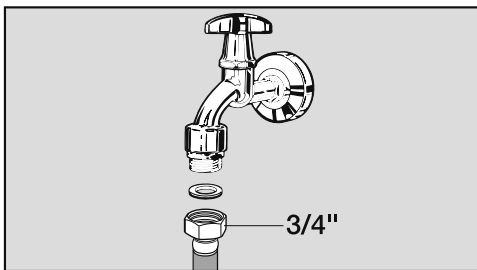

- Connect the stainless steel hose to the tap.
- Ensure that it is screwed into position correctly.
- Turn on the tap slowly and check for leaks. Correct the position of the seal and union if necessary.

You can now continue with the installation of the coffee machine.

## Electrical connection

Before connecting the appliance, make sure that the connection data on the data plate (voltage and frequency) matches the mains electricity supply. This data must correspond in order to avoid the risk of damage to the appliance. If in any doubt, consult a qualified electrician.

The necessary connection information is given on the data plate inside your appliance.

The fuse rating must be at least 10 A.

The socket should be easily accessible. If the socket is no longer accessible after installation, an additional means of disconnection must be provided for all poles. Suitable means of disconnection include switches with an all-pole contact gap of at least 3 mm. These include isolator switches, fuses and relays.

Temporary or permanent operation with a self-sufficient or non-mains synchronous energy supply system (e.g. isolated networks, back-up systems) is possible. A requirement for the operation is that the energy supply system complies with all current local and national requirements that apply to stand-alone, solar and/or battery systems.

The protective measures provided in the domestic installation and in this Miele product must also be assured in their function and operation in isolated operation or in non-mains synchronous operation, or replaced with equivalent measures in the installation.

The machine must not be used with so-called **energy-saving plugs**. These reduce the amount of energy supplied to the machine, causing it to overheat.

## Installation dimensions

### Installation in a tall unit

Maintain the required minimum installation height of 850 mm.

All dimensions are given in mm.

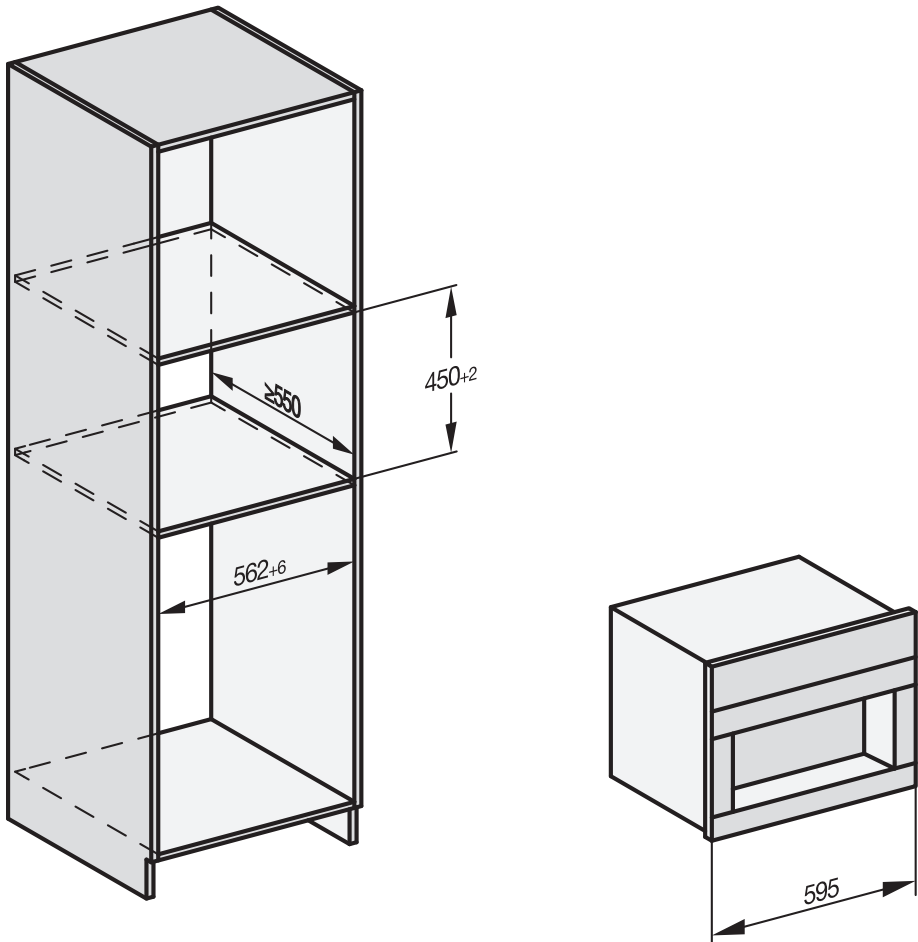

Combination with other Miele built-in appliances is possible. If the coffee machine is to be built in above another appliance, there must be a full-width, closed shelf between them. If the appliance is to be combined with a Gourmet warming drawer/ built-in vacuum sealing drawer, no intermediate shelf is required in between.

# Installation

## Installation and connections

All dimensions are given in mm.

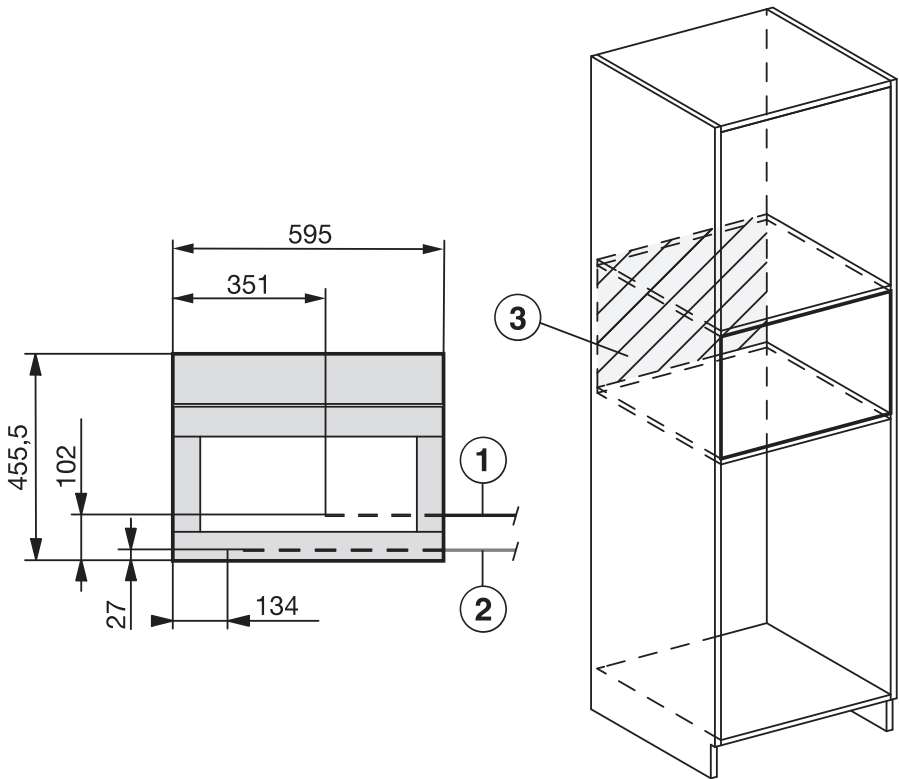

- ① Mains connection cable
- ② Mains water connection
- ③ Do not place electrical or mains water connections in this area



## Building in the coffee machine

 **Danger of injury due to incorrect operation.**

Personal injury can result from an incorrectly installed, and therefore unsecured, appliance.

Operate the coffee machine only in a built-in installation.

 **Risk of damage to property due to incorrect operation.**

If the ambient temperature range is not complied with, the coffee machine may not function correctly.

Operate the coffee machine only within a temperature range of +16 °C to +38 °C.

Maintain the required minimum installation height of 850 mm.

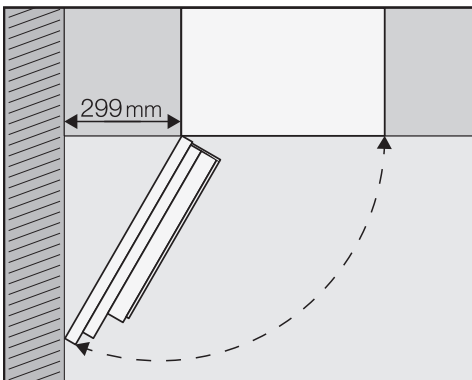

**Useful tip:** If the distance between an adjacent wall and the coffee machine is at least 299 mm, the appliance door can be opened wider, thus making the machine easier to use. This allows the left bean container to be removed more easily, for example.

A TX 20 screwdriver is required for installation.

**Useful tip:** We recommend providing a place to sit the coffee machine which is the same height as the building-in niche. This will make it easier to connect the machine to the electricity and water supply.

## Connecting to the mains water and electricity supply

Follow the instructions in "Mains water connection" and "Electrical connection".

- Connect the coffee machine to the mains water and electricity supply.

## Removing the transport safety device

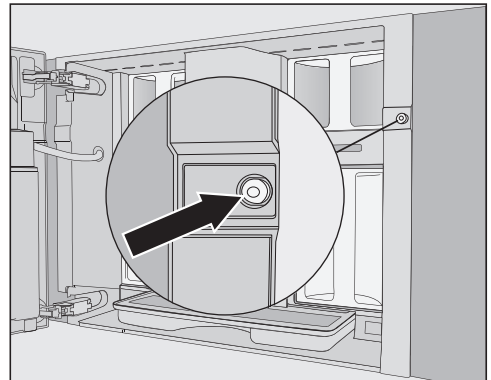

There is a red silicone plug inside the screw hole which secures the appliance door during transport to prevent transport damage.

Remove the silicone plug **before** screwing the coffee machine to the cabinet.

- Pull firmly on the red silicone plug to remove it from the screw hole.

The silicone plug is not required again. Dispose of it with your household waste.

# Installation

## Pushing in and levelling the coffee machine

Ensure the mains connection cable and mains water hose do not get jammed or damaged when pushing the appliance into the niche.

- Push the coffee machine all the way into the building-in niche.
- Check the height of the coffee machine to make sure that it is sitting centrally in the niche and that it is level. Align the appliance.

Do not adjust the door hinges to align the coffee machine. This could otherwise result in the milk flask not being able to be fitted correctly and milk preparation may not function properly.

You can now screw the coffee machine to the cabinet.

## Screwing the coffee machine to the cabinet

- Open the appliance door.

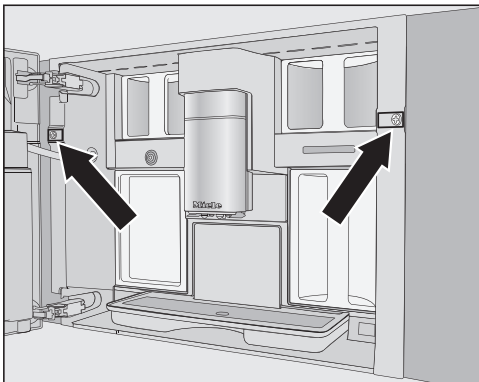

2 TX20 (25 mm) screws are supplied with the appliance.

- Secure the coffee machine to the side walls of the housing unit using the screws supplied. Tighten the screws by hand.

**Useful tip:** You can remove the door opening limiters and increase the door opening angle to 170° so that the screw on the left can be screwed in more easily (see "Door opening limiters"). Check whether there is enough room and that the appliance door does not hit an adjacent wall.

- Check the operation of the coffee machine.

## Door opening limiters

The door hinges of the coffee machine are equipped with door opening limiters that limit the opening angle of the appliance door to approx. 120°. These prevent the appliance door from hitting an adjacent wall when opened and being damaged.

You can remove the door opening limiters to increase the opening angle to approx. 170°. This allows the bean containers to be removed more easily, for example.

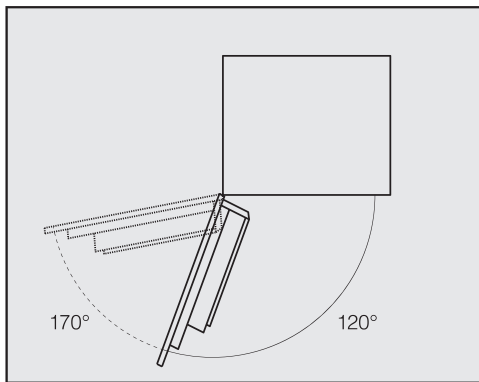

## Removing the door opening limiters

Check whether there is enough room and that the appliance door does not hit an adjacent wall when the door opening angle is increased.

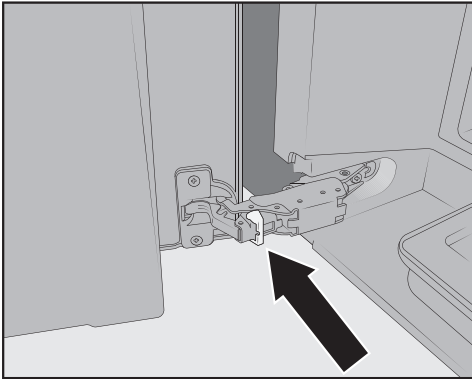

- Remove the door opening limiters from the hinges by levering them out with a screwdriver, for example.

The door opening angle is now increased to approx. 170°.

## Technical data

---

Electricity consumption in standby: < 0.8 Watt

Electricity consumption in networked standby: < 1.4 Watt

Frequency band of the Wi-Fi module 2.4000 GHz – 2.4835 GHz

Maximum transmission power of the Wi-Fi module < 100 mW

For the purpose of operating and controlling the appliance, Miele uses proprietary or third-party software that is not covered by open source licensing terms. These items of software/software components are protected by copyright. The copyright powers of Miele and third parties must be respected.

In addition, the appliance contains software components which are distributed under open source licensing terms. You can access these open source components along with the associated copyright notices, copies of the valid licensing terms and any further information in the appliance under [Settings](#) | [Legal information](#) | [Open source licences](#). The liability and warranty arrangements for the open source licences displayed at this location only apply in relation to the respective rights holders.

The appliance contains, in particular, software components which are licensed by the rights holders under the GNU General Public License, version 2, or the GNU Lesser General Public License, version 2.1. For a period of at least 3 years following the purchase or delivery of the appliance, Miele shall provide you or third parties with a machine-readable copy of the source code for the open source components contained in the appliance, which are licensed under the terms of the GNU General Public License, version 2, or the GNU Lesser General Public License, version 2.1. The source code shall be made available on a data carrier (CD-ROM, DVD or USB stick). To obtain this source code, please contact us, specifying the product name, serial number and purchase date, by sending us an e-mail ([info@miele.com](mailto:info@miele.com)) or writing to the following address:

Miele & Cie. KG  
Open Source  
GTZ/TIM  
Carl-Miele-Straße 29  
33332 Gütersloh, Germany

We wish to draw your attention to the limited warranty for the benefit of rights owners under the terms of the GNU General Public License, version 2, and the GNU Lesser General Public License, version 2.1:

*This program is distributed in the hope that it will be useful, but WITHOUT ANY WARRANTY, without even the implied warranty of MERCHANTABILITY of FITNESS FOR A PARTICULAR PURPOSE. See the GNU General Public License and GNU Lesser General Public License for more details.*



**Miele Australia Pty. Ltd.**

ACN 005 635 398

ABN 96 005 635 398

Level 4, 141 Camberwell Road  
Hawthorn East, VIC 3123

**1300 464 353 (1300 4 MIELE)**

**info@miele.com.au**

**www.miele.com.au**

**Miele New Zealand Limited**

IRD 98 463 631

8 College Hill  
Freemans Bay, Auckland 1011

**0800 464 353 (0800 4 MIELE)**

**customercare@miele.co.nz**

**www.miele.co.nz**

**Miele Global Headquarters**

**Germany**

**Miele & Cie. KG**

Carl-Miele-Straße 29

33332 Gütersloh

Federal Republic of Germany

CVA 7845

en – AU, NZ

M.-Nr. 12 876 510 / 00